

THIS SPACE FOR DESIGNER/ ENGINEER APPROVAL

Job/Customer _____ Date _____ Contractor _____

Model Specified _____ Qty _____ Approved By _____

Designer/Engineer _____ Date _____ Contractor's PO# _____

Submitted by _____ Date _____ Other _____

4061 Ball Drain™ Full Port Forged Brass Ball Valves w/ Hi-Flow Hose Drains & Reversible Handle IPS 600 WOG



ITEM #	SIZE	P/CARTON	P/CASE	A	B	C	D	E	F
40612	1/2"	6	60	1/2	2 5/16	1 13/16	3 3/8	2 1/4	5/16
40613	3/4"	6	60	3/4	2 13/16	1 15/16	4	2 7/16	5/16
40614	1"	4	48	1	3 1/8	2 7/16	4 7/8	2 11/16	5/16
40615	1 1/4"	2	32	1 1/4	3 15/16	2 7/8	4 11/16	2 7/8	9/16
40616	1 1/2"	2	24	1 1/2	4 3/8	3 5/16	5 1/4	3 1/16	9/16
40617	2"	1	12	2	4 7/8	3 5/16	5 3/8	3 3/8	9/16



NO.	DESCRIPTION	MATERIAL
1	BODY	BRASS
2	END CAP	BRASS
3	SEAT	PTFE
4	BALL	BRASS HCP
5	STEM	BRASS
6	STEM SEAL	PTFE
7	PACKING GLAND	BRASS
8	HANDLE	STEEL CP
9	HANDLE JACKET	VINYL
10	HANDLE NUT	STEEL ZP
11	END CAP	BRASS
12	SEAT	PTFE
13	BALL	BRASS HCP
14	STEM	BRASS
15	STEM SEAL	PTFE
16	PACKING GLAND	BRASS
17	HANDLE	ALUMINUM
18	HANDLE SCREW	BRASS
19	CAP & STRAP	BRASS
20	WASHER	NBR

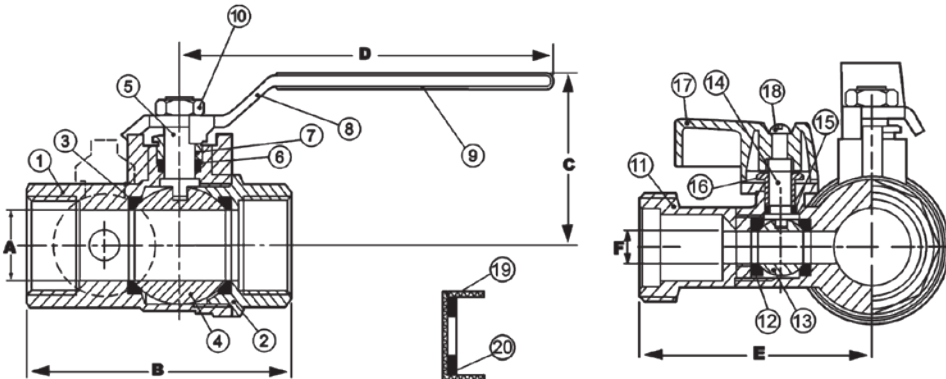

TEMP °F	WOG
100	600
150	490
200	470
250	439
300	411
350	294
366	N/A

Specifications: Designed for residential, commercial or industrial use with water, oil or gas. Designed by Webstone for the PRO-PAL® series of valves, this approved Webstone valve saves time and money when installed in any system that requires a drain. Ideal for use directly after a water meter to isolate a home and purge the system. The valve is actuated by a blowout proof stem and features an adjustable packing nut. Threaded ends comply with ANSI B1.20.1.

Webstone Company, Inc.
www.webstonevalves.com

Quality and Commitment Since 1954

Tel: (800) 225-9529 • Fax (800) 336-5133

Webstone product specifications in U.S. customary units are approximate and are provided for reference only. Webstone reserves the right to change or modify product design, construction, specifications or materials without prior notice and without incurring any obligation to make such changes and modifications on Webstone products previously or subsequently sold.

4061spec_062309