

THIS SPACE FOR DESIGNER/ ENGINEER APPROVAL

Job/Customer _____ Date _____ Contractor _____
 Model Specified _____ Qty _____ Approved By _____
 Designer/Engineer _____ Date _____ Contractor's PO# _____
 Submitted by _____ Date _____ Other _____

40782 Series
 CHROME PLATED EXTRUDED BRASS MINI BALL VALVES
 HEX BODY
 PEX
 110 WOG NON-SHOCK

ITEM #	SIZE	P/CARTON	P/CASE	A	B	C	D
40782	1/2"	12	144	3/8	2 1/4	1 1/4	1 1/8

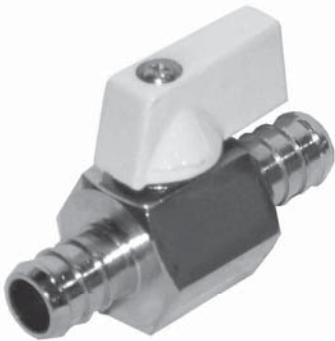

NO.	DESCRIPTION	MATERIAL
1	BODY	EXTRUDED BRASS BAR STOCK
2	CAP/BUSHING	BRASS
3	SEAT	PTFE
4	BALL	BRASS HCP
5	STEM	BRASS
6	O-RING	CR
7	HANDLE	ZINC W/ EPOXY COATING
8	HANDLE SCREW	BRASS

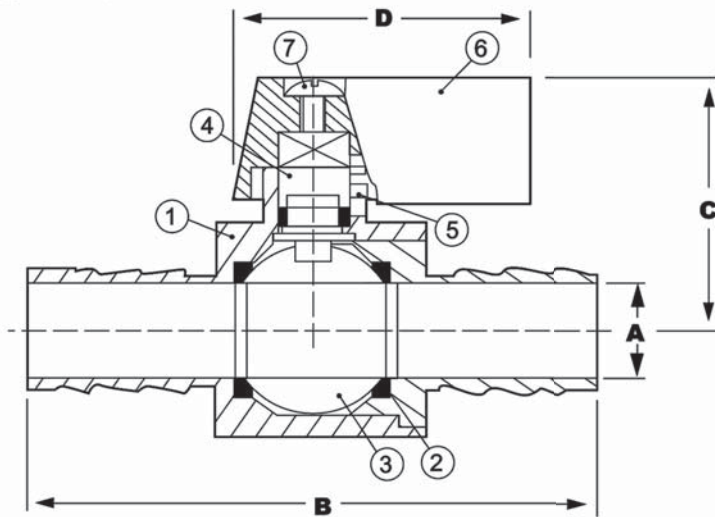

TEMP °F	WOG
100	200
150	163
200	157
250	146
300	137
350	98
366	N/A

Specifications: Designed for commercial and industrial use with water, oil, or gas. Compact design makes this valve versatile for many applications in small lines. This approved Webstone valve is actuated by a blowout proof stem.

Webstone Company, Inc.
 www.webstonevalves.com

Quality and Commitment Since 1954

Tel: (800) 225-9529 • Fax (800) 336-5133

Webstone product specifications in U.S. customary units are approximate and are provided for reference only. Webstone reserves the right to change or modify product design, construction, specifications or materials without prior notice and without incurring any obligation to make such changes and modifications on Webstone products previously or subsequently sold.

40782spec_081009