

THIS SPACE FOR DESIGNER/ ENGINEER APPROVAL

Job/Customer _____ Date _____ Contractor _____

Model Specified _____ Qty _____ Approved By _____

Designer/Engineer _____ Date _____ Contractor's PO# _____

Submitted by _____ Date _____ Other _____

4063 Series FULL PORT FORGED BRASS BALL VALVES W/ COMPRESSION ENDS COMPRESSION x COMPRESSION 600 WOG / 150 WSP

ITEM #	SIZE	P/CARTON	P/CASE	A	B	C	D	Cv
40632	1/2"	25	100	1/2	2 15/16	2	3 1/2	11.5
40633	3/4"	15	60	3/4	3 3/16	2 3/16	3 3/4	27.1
40634	1"	10	40	1	4 1/8	2 5/8	4 5/8	49.3



NO.	DESCRIPTION	MATERIAL
1	BODY	BRASS
2	END CAP	BRASS
3	SEAT	PTFE
4	BALL	BRASS HCP
5	STEM	BRASS
6	STEM SEAL	PTFE
7	PACKING GLAND	BRASS
8	HANDLE	STEEL CP
9	HANDLE NUT	STEEL CP
10	HANDLE JACKET	VINYL
11	FERRULE	BRASS
12	COMPRESSION NUT	BRASS

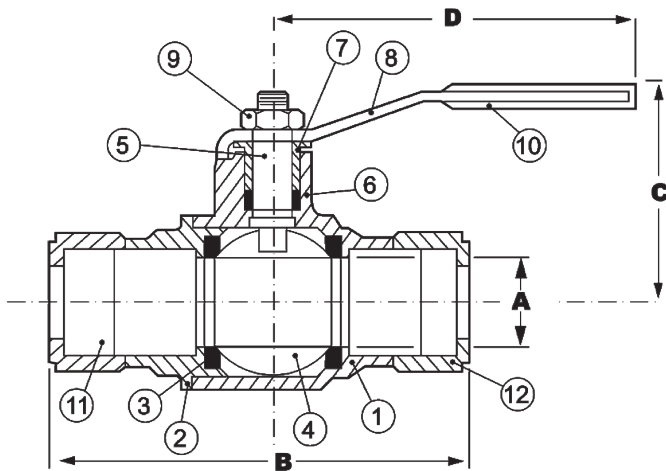

TEMP °F	WOG
100	600
150	490
200	470
250	439
300	411
350	294
366	N/A

Specifications: Designed for residential, commercial or industrial use with water, oil or gas. This approved Webstone Valve is actuated by a blowout proof stem and features an adjustable packing gland. Compression ends are labor saving and eliminate the risk of damaging seats while soldering. Valve replacement or disconnecting the plumbing system is also an easy job.

Webstone Company, Inc.
www.webstonevalves.com

Quality and Commitment Since 1954

Tel: (800) 225-9529 • Fax (800) 336-5133

Webstone product specifications in U.S. customary units are approximate and are provided for reference only. Webstone reserves the right to change or modify product design, construction, specifications or materials without prior notice and without incurring any obligation to make such changes and modifications on Webstone products previously or subsequently sold.

4063spec_101909