

# THIS SPACE FOR DESIGNER/ ENGINEER APPROVAL

Job/Customer \_\_\_\_\_ Date \_\_\_\_\_ Contractor \_\_\_\_\_

Model Specified \_\_\_\_\_ Qty \_\_\_\_\_ Approved By \_\_\_\_\_

Designer/Engineer \_\_\_\_\_ Date \_\_\_\_\_ Contractor's PO# \_\_\_\_\_

Submitted by \_\_\_\_\_ Date \_\_\_\_\_ Other \_\_\_\_\_

## 4390 Series STANDARD PORT 316 STAINLESS STEEL BALL VALVES 1 PIECE INVESTMENT CAST W/ 304 STAINLESS STEEL LOCKING HANDLE IPS - 1000 WOG / 150 WSP - ISO 9001:2008

ITEM #	SIZE	P/CARTON	P/CASE	A	B	C	D	Cv
43900	1/4"	4	200	1/4	1 1/2	1 5/16	2 3/4	4.8
43901	3/8"	4	200	3/8	1 11/16	1 5/16	3	6.2
43902	1/2"	2	100	1/2	2 3/16	1 1/2	3 7/8	7.6
43903	3/4"	2	80	11/16	2 5/16	2	3 7/8	13.6
43904	1"	2	50	7/8	2 13/16	2 3/16	4 13/16	25.0
43905	1 1/4"	2	30	1	3	2 7/16	4 13/16	36.3
43906	1 1/2"	2	30	1 1/4	3 3/8	2 15/16	5 3/4	92.0
43907	2"	2	30	1 1/2	3 15/16	3 1/4	5 3/4	139.4



NO.	DESCRIPTION	MATERIAL
1	HANDLE JACKET	PLASTIC
2	LOCKING	STAINLESS STEEL 304
3	HANDLE	STAINLESS STEEL 304
4	HANDLE NUT	STAINLESS STEEL 304
5	SPRING WASHER	STAINLESS STEEL 304
6	STEM	STAINLESS STEEL 316
7	PACK RING	STAINLESS STEEL 304
8	PACKING GLAND	PTFE
9	THRUST WASHER	PTFE
10	END CAP	STAINLESS STEEL 316
11	BODY	STAINLESS STEEL 316
12	SEAT	PTFE
13	BALL	STAINLESS STEEL 316

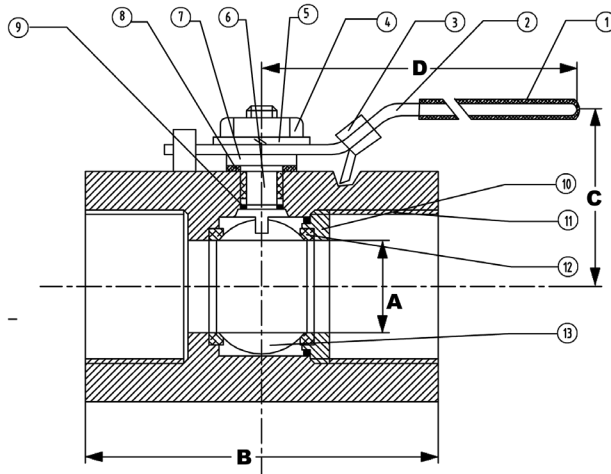

TEMP °F	WOG
100	1000
150	1000
200	1000
250	1000
300	1000
350	N/A
366	N/A

Specifications: Designed for commercial and industrial use with a broad range of fluid handling applications. This approved Webstone valve is actuated by a blowout proof stem and features an adjustable packing nut with locking device. Threaded ends comply with ANSI B1.20.1

**Webstone** Company, Inc.  
www.webstonevalves.com

Quality and Commitment Since 1954

Tel: (800) 225-9529 • Fax (800) 336-5133

Webstone product specifications in U.S. customary units are approximate and are provided for reference only. Webstone reserves the right to change or modify product design, construction, specifications or materials without prior notice and without incurring any obligation to make such changes and modifications on Webstone products previously or subsequently sold.

4390spec\_102009