

SECUREMOTETM Garage Installation Guide

SecuRemoteTM for Blackberry®

Download the SecuRemoteTM Application for Blackberry®

1. Download the app through the Blackberry® App WorldTM on your smartphone.
2. Type in "SecuRemote".
3. Once the SecuRemoteTM app appears, select "Download App".
4. Download the application. By default, the SecuRemoteTM application icon is placed in the downloads folder.
5. Make sure your Bluetooth® is turned on. To pair, your smartphone must be within 60-100 ft. of the SecuRemoteTM device.

SecuRemoteTM for Android™

Download the SecuRemoteTM Application for Android™

1. Download the app through the Android™ Market on your smartphone.
2. Type in "SecuRemote".
3. Once the SecuRemoteTM app appears, select "Download App".
4. Download the application. By default, the SecuRemoteTM application icon is placed on your home screen.
5. Make sure your Bluetooth® is turned on. To pair, your smartphone must be within 60-100 ft. of the SecuRemoteTM device.

SecuRemoteTM for iPhone®

Download the SecuRemoteTM Application for iPhone®

1. Download the app through the App StoreSM on your smartphone.
2. Type in "SecuRemote".
3. Once the SecuRemoteTM app appears, select "Download App".
4. Download the application. By default, the SecuRemoteTM application icon is placed on your home screen.
5. Make sure your Bluetooth® is turned on. To pair, your smartphone must be within 60-100 ft. of the SecuRemoteTM device.

Installing the SecuRemoteTM Device

1. Unwrap the SecuRemoteTM device and take note of the serial number on the side of the device. You and your users will need it when pairing the device with your smartphone.
2. Attach the mounting plate (a) to a wall or ceiling location close to an AC outlet using the screws included in the box. Or use double-sided tape to place the device near the garage door opener OR alternately near the wall console.

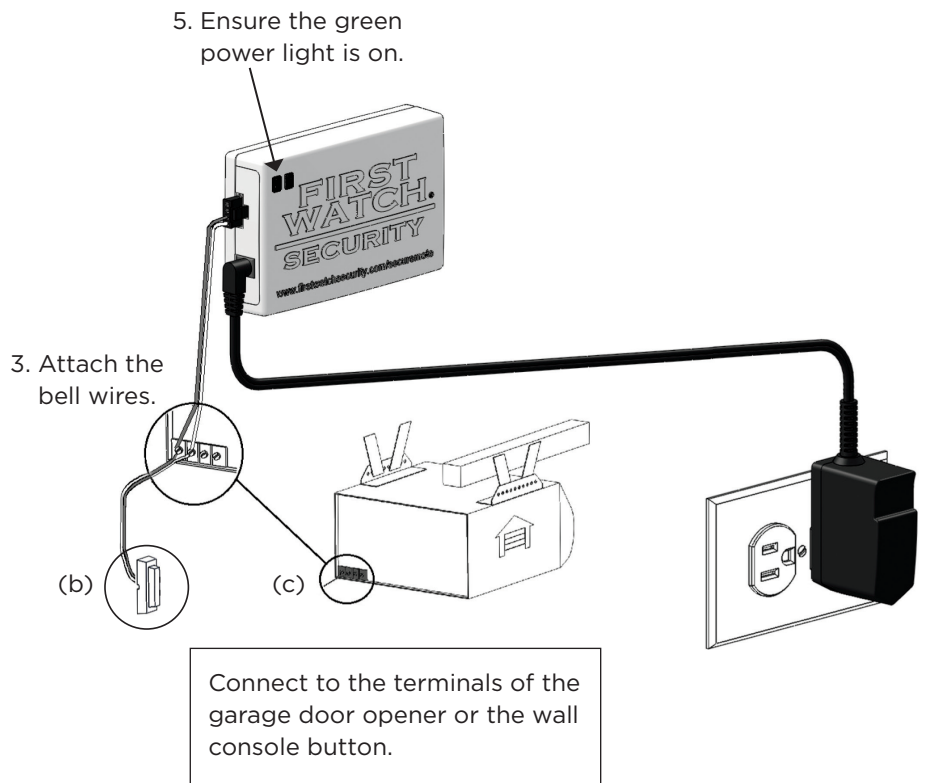
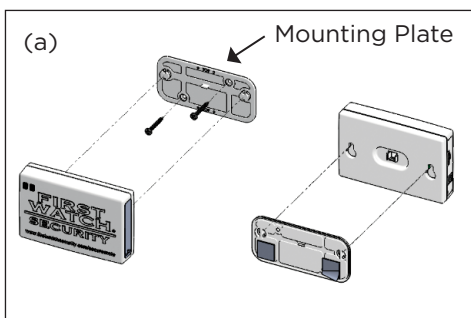

3. Attach the Bell Wires of the SecuRemoteTM device to (b) the wall console button or (c) to the control connectors on the door opener. Match the wire colors together. Do not disconnect the existing wires to the garage door unit. (To avoid electric shock, DO NOT insert wires into A/C outlet!)
4. Operate the door from close to open to close again.
5. The blue light on the SecuRemoteTM device will flash for a few seconds, indicating you have correctly installed the Status Monitor.

Two ways to learn even more

1. Visit us at www.firstwatchsecurity.com to download an extensive user manual for each mobile phone platform.
2. Extend the capabilities and security of SecuRemoteTM beyond what's available "out of the box" with scheduling, auditing, and other features at www.firstwatchonline.com

Additional Information

Please contact our customer service at 888-845-9597 for additional questions.

SECUREMOTETM Status Monitor Installation Guide

1. Remove the Location Marker Cover. With the garage door in the closed position, install the Location Marker on the top of the garage door. Replace the Location Marker Cover.
2. Remove the Location Sensor Cover. Install the Location Sensor on the garage wall within 2" of the Location Marker (d). Replace the Location Sensor Cover.
3. Tack the two white wires to the wall with the supplied wire staples.
4. Operate the door from close to open to close again.
5. The blue light on the SecuRemoteTM device will flash for a few seconds, indicating you have correctly installed the Status Monitor.

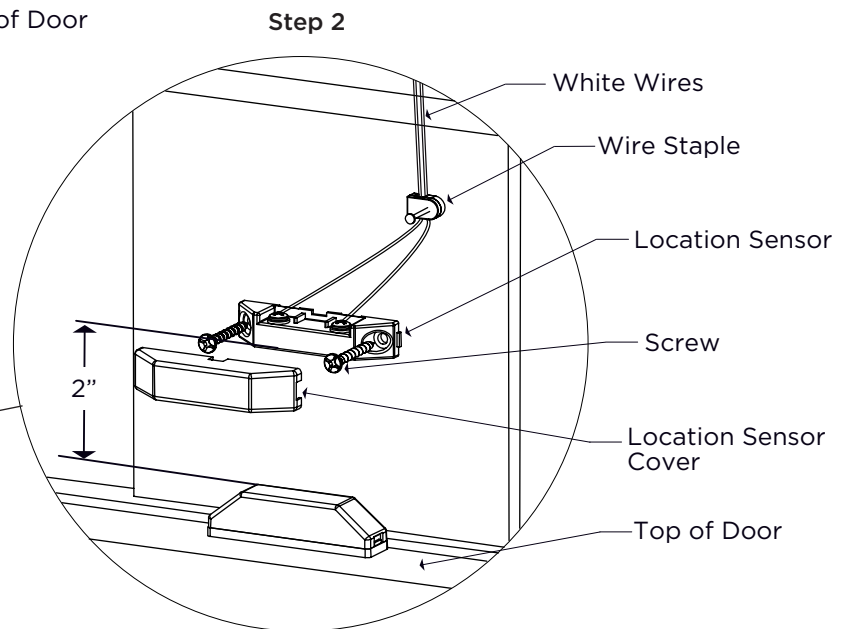
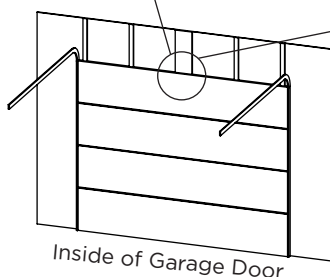
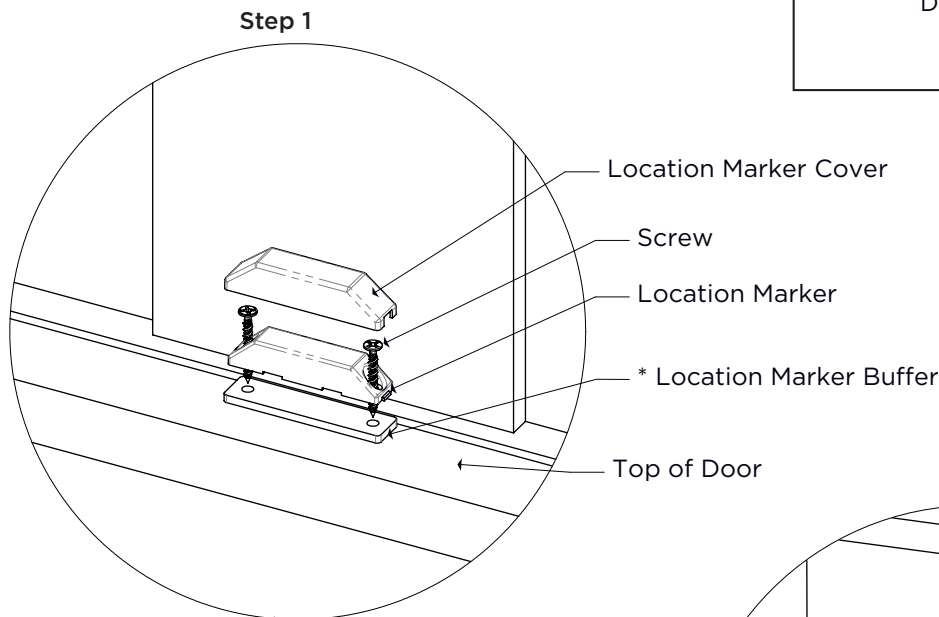
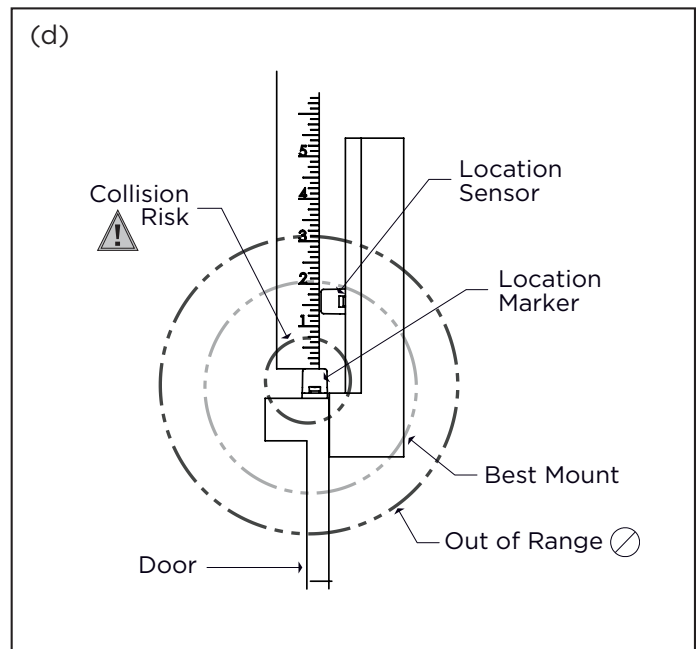

* = Location Marker Buffer only required on Steel Doors

The Bluetooth® trademarks are owned by their proprietor and used by Belwith® Products, LLC under license. iPhone® and App Store™ are trademarks of Apple Inc., registered in the U.S. and other countries. U.S. distribution only. All other product or service names are the property of their respective owners.