

Type _____

-09

P4260

P4261

P4262

Catalog No.	Finish Brushed Nickel	Lamping	Dimensions (Inches)		
			A	B	C
P4260	-09	3(m) 100w	17-3/4	23-3/4	48-1/2
P4261	-09	5(m) 100w	23-3/4	24-1/4	48
P4262	-09	9(m) 100w	30	31	53

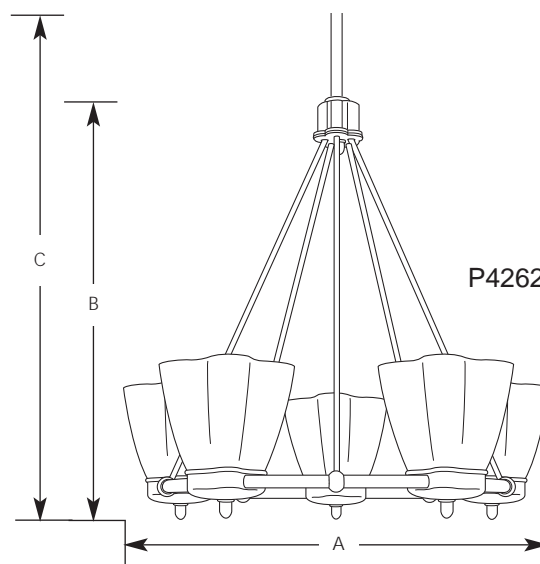
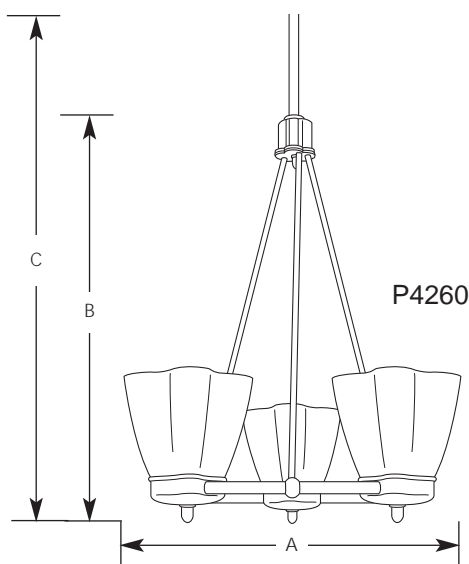

Specifications:

General

- Etched opal glass shades
- Uniquely inflected curved shades with four sides
- Shades rod supported
- P4262 is a two tier (6/3) chandelier
- P4260 has one 10" & one 12" sections of matching stem, P4261 has two 10" , and P4262 has one 4" and one 15" sections supplied. Stems have internal thread couplers to attain various desired lengths
- Steel construction
- Plated brushed nickel finish
- Companion hall & foyer, sconce, mini-pendant, close to ceiling and recessed trim units

Mounting

- Stem hung ceiling
- Canopy covers a standard recessed 4" octagonal outlet box
- Mounting strap for outlet box included

Electrical

- 15 feet of wire
- Ceramic medium based sockets
- Threaded socket ring secures glass
- Pre-wired

Labeling

- UL-CUL listed