

INSTALLATION INSTRUCTIONS FOR 9801- PL

For Wall Sconce Fixture

READ AND SAVE THESE INSTRUCTIONS

WARNING! SHUT POWER OFF AT FUSE OR CIRCUIT BREAKER .
AVERTISSEMENT ! COUPER LE COURANT AUNIVEAU DES FUSIBLES OU DU DISJONCTEUR

MOUNTING THE FIXTURE (Fig.1)

1. Shut off the power at the circuit breaker box (avertissement! couper le courant au niveau des fusibles ou du disjoncteur) and remove the old fixture, including the mounting hardware.
2. Carefully unpack your new fixture and lay out all the parts on a clear area. Take care not to lose any small parts necessary for installation.
3. Attach the crossbar (Part#A-010) to the junction box with the two mounting screws(Size:8-32*1/2"L) as shown. The side of the crossbar marked "GND" must face out.
4. Thread the nipple part way into the center hole of the crossbar. The length of the nipple into the crossbar may be adjusted if necessary.

CONNECTING THE WIRES (Fig.2)

5. Connect the electrical wires as shown in Fig. 2. Make sure that all wire connectors are secured. If your outlet has a ground wire (green or bare copper), connect the fixture's ground wire to it. Otherwise, connect the fixture's ground wire directly to the circular strap using the green screw provided. Tuck the wire connections neatly into the junction box.

COMPLETING THE INSTALLATION (Fig.1)

6. Align the fixture back plate to the nipple and secure with the cap nut provided
7. Notice: To comply with UL Standards and maintain product warranty, use clear silicone sealant to outline the outside of the fixture back plate where it meets the wall to prevent moisture from entering the junction box while leaving a space at the bottom to allow moisture to escape (Fig. 4.). Failure to do so will void any expressed warranty.
8. Install the PL lamp in accordance with the fixture's specification. (1xMax13W included). Note: To prevent damage to the bulb during installation, hold the bulb by the base only while installing into the socket. **(DO NOT EXCEED THE MAXIMUM WATTAGE RATING!!)** (NE PAS DEPASSER LA PUISSANCE NOMINALE MAXIMALE)
9. The ballast in each of these models can be replaced by a qualified electrician without cutting of wires and without damage to the housing, trim, decorative elements or carpentry to which the fixture is attached. See installation steps for more detail. The ballast and lamp are combined, to replace or install, twist pins into socket as shown on Fig.3.
10. Place the glass with the marked arrow on the topside into the fixture and secure the steel glass support bar with the screws provided.
11. This fixture is rated for a minimum start temperature of -17° Celsius.
12. This fixture is ETL Listed for Wet Location applications.

Your installation is now complete. Return power to the junction box and test the fixture.

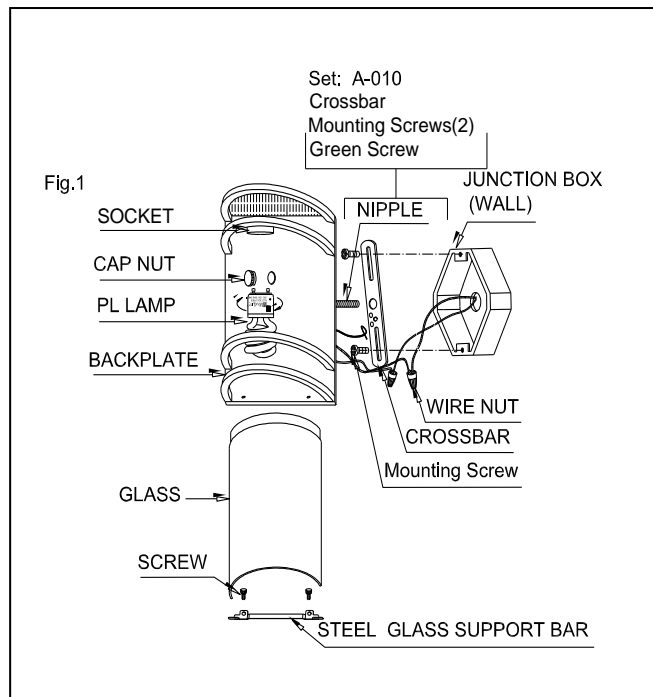

Fig. 2

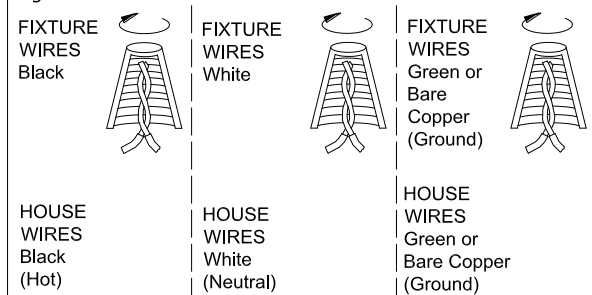

Fig.3

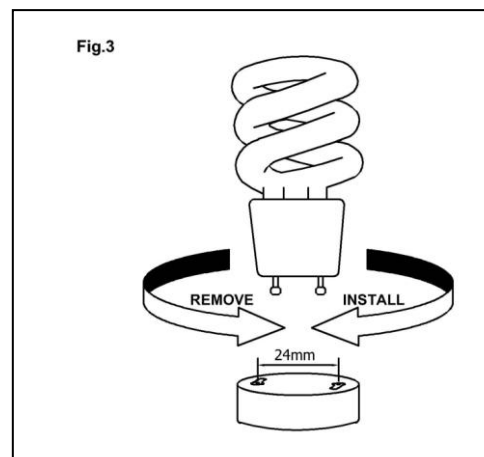

Fig.4

