



✉ 33 West Beaver Creek Road Richmond Hill  
 Ontario Canada L4B 1L8  
 ☎ 800.660.5391  
 📠 800.660.5390  
 📧 info@eurofase.com  
 🌐 www.eurofase.com



## MARIAH , 12-LIGHT CHANDELIER

### Product Specifications

Model No.: 19476  
 Height: 58.63"  
 Chain / Cord Length: 180"  
 Diameter: 32.63"  
 Est. Shipping Weight: 70.444 lbs  
 No. of Bulbs: 12  
 Bulb Wattage: 60 watts  
 Bulb Type: B10   
 Bulb Base: E12  
 Bulb Voltage: 120 volts

### Options Available

ITEM CODE	FINISH	SHADE
19476-018	black	clear glass

### Colour / Shades Available

FINISH	SHADE
black	 clear glass

The Mariah series is immediately the centre of attention in any setting. Stunning diaphanous crystal shades are paired with draped strands of crystal beads. Midnight black architecture is the perfect balance to the Gothically ornate aestheticism this family embodies.

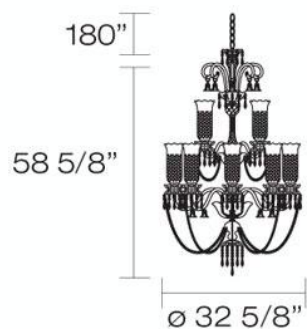

### Project Information

Job Name: \_\_\_\_\_ Date: \_\_\_\_\_ Type: \_\_\_\_\_  
 Comments: \_\_\_\_\_