

Specification Sheet

Pendant

Model: **F1935-36 Satin Nickel**
F1935-68 Deep Bronze

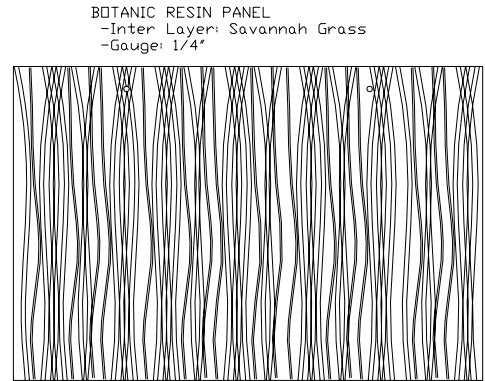
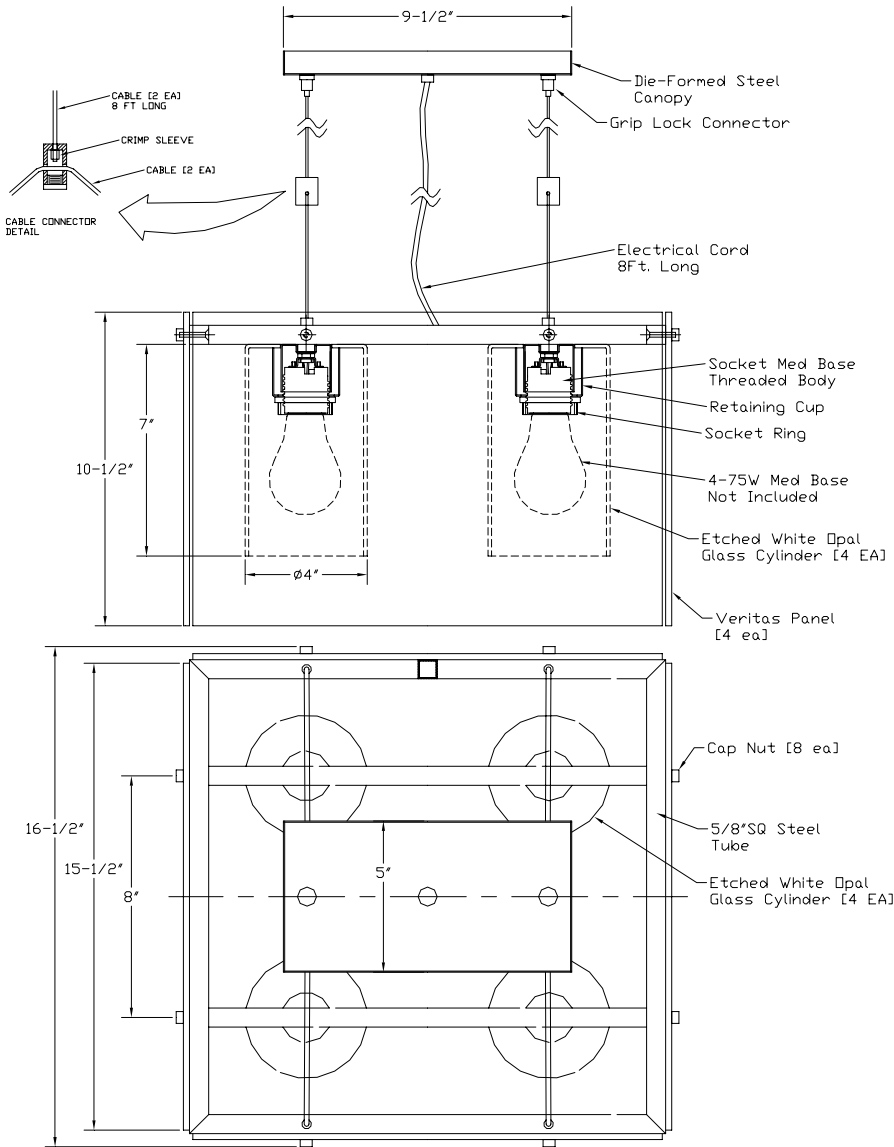

Panel: Resin Botanic Panels by Veritas
 Glass: Etched White Opal
 Finishes: Satin Nickel -36; Deep Bronze -68
 Width: 16-1/2" Height: 10-1/2" Overall Height: 106"
 Lamps: 4 – 75W Medium Base (Not Included)
 Labels: cULus Listed. Suitable for Dry Location.