

# Assembly & Installation Instructions

For Wren Five Light Pendant 13-6605

**A230**

Page 1 of 4

**CAUTION: FAILURE TO INSTALL THIS FIXTURE PROPERLY MAY RESULT IN SERIOUS PERSONAL INJURY OR DEATH AND PROPERTY DAMAGE. We recommend installation by a licensed electrician.**

This product must be installed in accordance with applicable installation code(s), by a person familiar with the construction and operation of the product and the hazards involved.\*

**Caution:** Do not exceed maximum wattage noted on fixture. Use only recommended bulbs with fixture.

## To Attach Fixture Pipes (Figure 1)

### Component Parts

- A Fixture Pipe (2)
- B Fixture Coupling (2)

1. Carefully unpack the fixture from the carton.
2. Carefully thread fixture pipe (A), threaded end first, over fixture wires.
3. Apply a drop of the supplied thread locking compound to the internal threads at the top of the fixture (B) and screw stem into fixture, being careful not to twist the wires.

**Note:** Application of the thread locking compound is necessary to prevent the stem from loosening during regular maintenance and cleaning of the fixture. Be certain to apply the compound.

4. See instructions below to complete the installation.

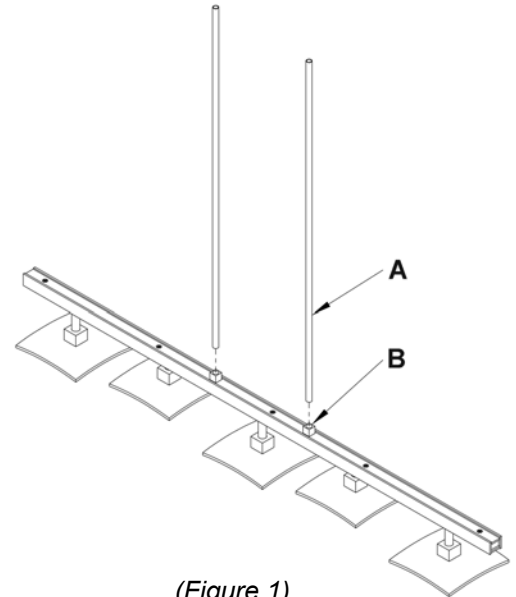

(Figure 1)

## To Assemble Canopy Pipes to Ceiling Bracket (Figure 2)

### Component Parts

- C Hex Nipple (2)
- D Lock Washer (2)
- E Ceiling Bracket
- F Canopy Pipes (2)
- G Canopy
- H Clutch

1. Slip canopy pipes (F) through canopy (G).
2. Insert threaded end of hex nipple (C) down through lock washer (D), ceiling bracket (E) and into threaded end of canopy pipe (F) and tighten.

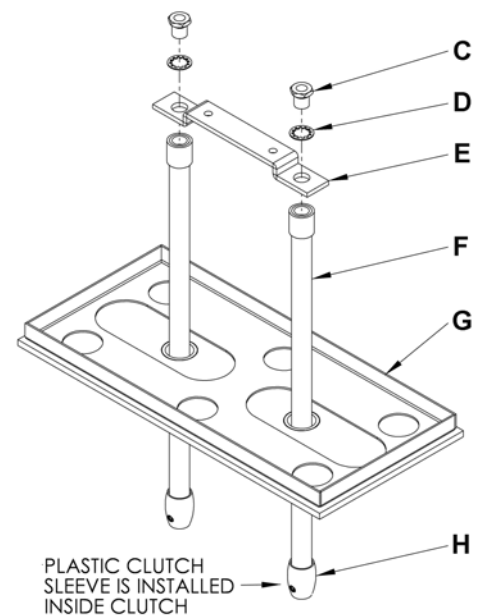

(Figure 2)

(continued)

# Assembly & Installation Instructions

For Wren Five Light Pendant 13-6605

**A230**

Page 2 of 4

## To Complete Fixture Assembly (Figures 3 & 4)

### Component Parts

A	Fixture Pipe (2)	H	Clutch (2)
C	Hex Nipple (2)	I	Plastic Clutch Sleeve (2)
F	Canopy Pipe (2)	J	Set Screw (2)
G	Canopy		

**Caution: Be sure power is off at the main breaker box prior to installation.**

1. Slip canopy (G) over fixture pipes (A). Lower until canopy (G) is resting on top of fixture. Be careful not to scratch the pipe surfaces.
2. Run wires through canopy pipes (F) and out hex nipples (C).
3. Unscrew the clutch (H) from the canopy pipe (F); slide it across the wires and onto the fixture pipe (A). Follow this with the plastic clutch sleeve (I), oriented so the tapered end of the clutch sleeve nests in the clutch (Figure 3).
4. Slide the canopy pipe (F) as far as necessary to give you the total length of the fixture which you desire. Be careful not to scratch the pipe surfaces and to pull excess wire up through the canopy pipe (F). Screw clutch (H) onto canopy pipe (F). There must be a minimum 1-1/2" of inner pipe inside the outer pipe. Hand-tighten the clutch to temporarily hold this adjustment. The clutch is not securely fastened at this point; do not depend on it to hold the fixture. **Important:** To ensure full connection strength, be sure the tapered end of the plastic clutch sleeve is oriented toward the clutch when assembled and securely tighten set screw (Figure 3).
5. Continue with Ceiling Installation.

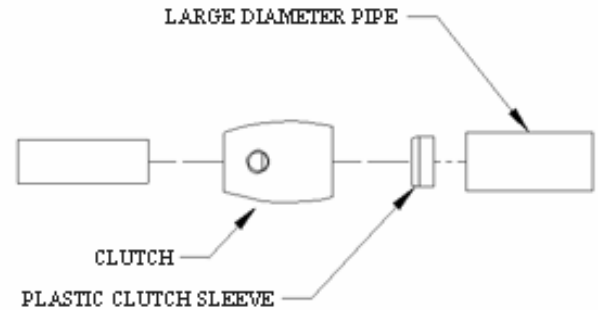

(Figure 3)

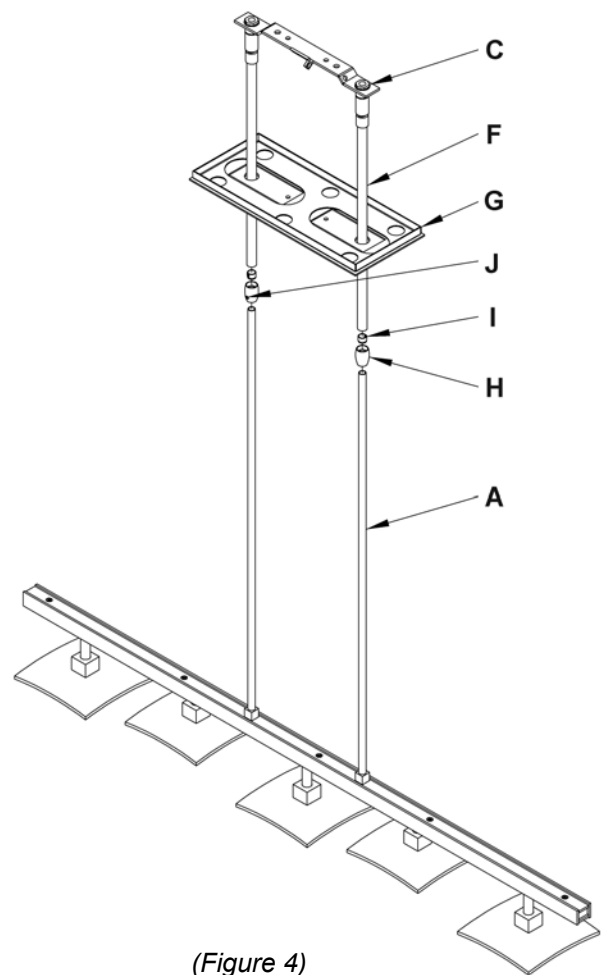

(Figure 4)

(continued)

# Assembly & Installation Instructions

For Wren Five Light Pendant 13-6605

**A230**

Page 3 of 4

## To Install to Ceiling (Figure 5)

### Component Parts

E Ceiling Bracket	M Lag Screw (4)
G Canopy	N Threaded Stud (2)
J Set Screw (2)	O Hex Nut (2)
K Crossbar	P Barrel Knob (2)
L Stud (2)	

1. Thread studs (N) through appropriate holes in crossbar (K) to match holes in canopy (G).
2. Using two machine screws (not provided) fasten cross bar (K) to the electric box using tab holes to orient fixture to desired hanging position. **Note:** A new electric box comes with screws. When replacing an existing fixture, retain the screws for use with the new fixture.

Alternate Mounting Option - Using four lag screws (M) attach crossbar (K) to a structural member in the ceiling, centering the crossbar over the outlet box. We've supplied lag screws with your fixture; however, different materials and/or construction methods may require different fasteners. If in doubt, contact a qualified electrician.

3. Raise fixture to ceiling aligning studs in crossbar (K) with holes in ceiling bracket (E).
4. Thread hex nut (O) onto studs (L) and tighten.
5. Using suitable wire connectors (not provided) connect fixture wires to supply (white to white and black to black, and bare copper to bare copper or green supply). Push wires back into outlet box. **Caution:** Make sure wire connectors are twisted on securely, and no bare wire is exposed.
6. Raise canopy (G) to ceiling over threaded studs (N) and push firmly to ceiling, making sure that no wires are pinched between canopy and ceiling. Fasten with barrel knob (P).

**Note:** Be sure both swivel notches are aligned in the same direction. For sloped ceilings the notches should face towards the down side.

7. Once the fixture is fastened to the ceiling, tighten the set screw (J) firmly with hex wrench provided. Only after the set screw (J) is tight should you install the glass.
8. Refer to instructions below to install glass.

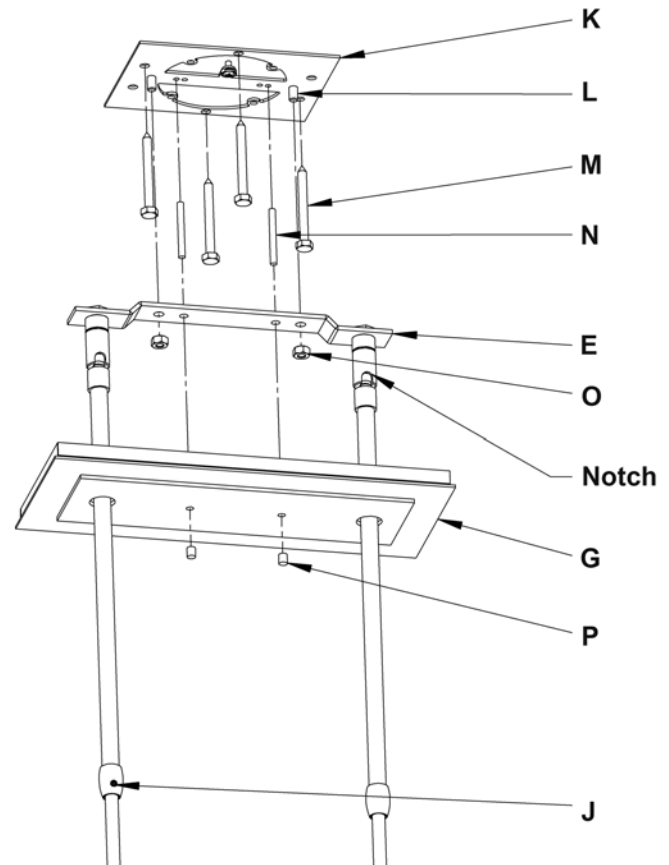

(Figure 5)

# Assembly & Installation Instructions

For Wren Five Light Pendant 13-6605

**A230**

Page 4 of 4

## **To Install Glass with G9 Option** (Figure 6)

### Component Parts

- Q Glass (5)
- R Socket (5)
- S Bulb (Included) (5)
- T Bulb Shield (5)
- U Spacer (5)

1. Install light bulb (S). Be careful not to touch bulb with bare hands; oil from the hands will dramatically reduce bulb life.
2. Slip glass (Q) over socket (R).
3. Place spacer (U) on bulb shield (T) (*note orientation of spacer*).
4. Thread bulb shield (T) onto socket (R) (be careful not to over tighten). Future bulb changes may be accomplished by snapping glass portion of barrier on and off rather than unthreading the holder.
5. Restore electricity at main breaker.

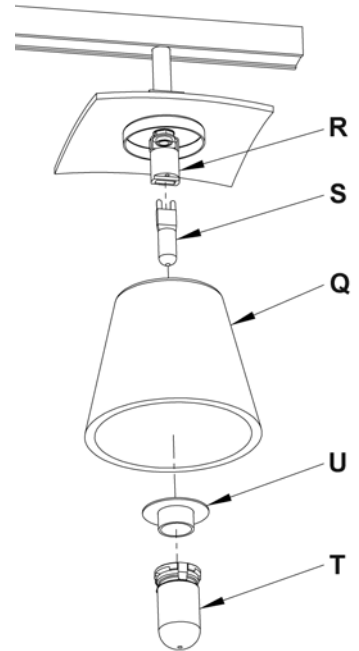

(Figure 6)

## **To Install Double Glass with G9 Option** (Figure 7)

### Component Parts

- Q Glass (5)
- R Socket (5)
- S Bulb (Included) (5)
- T Bulb Shield (5)
- U Spacer (5)
- V Inner Glass (5)
- W Retaining Ring (5)
- X Retaining Ring Tool

1. Install light bulb (S). Be careful not to touch bulb with bare hands; oil from the hands will dramatically reduce bulb life.
2. Slip glass (Q), inner glass (V) & spacer (U) (*note orientation of spacer*) over socket (R).
3. Thread retaining ring (W) onto socket (R) using provided retaining ring tool (X).
4. Thread bulb shield (T) onto socket (R) (be careful not to over tighten). Future bulb changes may be accomplished by snapping glass portion of barrier on and off rather than unthreading the holder.
5. Restore electricity at main breaker.

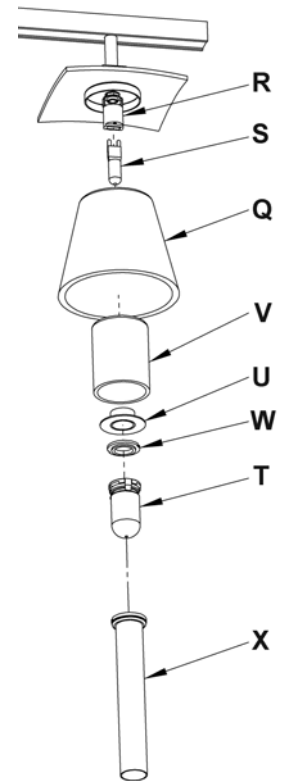

(Figure 7)

*If you need further assistance, or find that you are missing any parts, please contact the dealer from which you purchased this product. We hope you enjoy your fixture!*

\* Hubbardton Forge will not be liable for injury or damage caused by improper installation, lamping or use of this fixture.