

- 1) Assemble arms (JJ) to body (Y) using lockwashers and hexnuts (see Fig. 2A). Tighten hexnuts using provided wrench.
- 2) **BOTTOM TIER WIRING**
 - A) Take 2-6", 1-50" black and 2-6", 1-50" white jumper wires from parts bag.
 - B) Connect 6" black jumper wire to 4 black socket wires using provided connectors. Repeat for white wires.
 - C) Connect 6" black jumper wire to 4 black socket wires using provided connectors. Repeat for white wires.
 - D) Connect 2-6" black jumper wires, 50" black jumper.

CAUTION: Make sure all wires are stripped 5/8" (16 mm) and no loose wire strands are outside the connectors. As an added precaution, slightly tug on each wire to ensure that each on is secure inside wire connector and then wrap the connection with electrical tape.

- 3) Slip safety cable and 50" jumper wire through hole in side of coupling FF and through hole in top of coupling.
- 4) Slip safety cable and 50" jumper wire through threaded pipe inside column (A).
- 5) Apply a small amount of thread locking compound to threaded pipe at bottom of column (A) and screw into hickey (FF). Make sure all wires are tucked into body (Y) and do not get pinched or twisted during assembly.
- 6) Assemble arms (AA) to body (BB) at top of column (A) using lockwashers and hexnuts (see Fig. 2A). Tighten hexnuts using provided wrench.

7) MIDDLE TIER WIRING

- A) Take 4-6", black, 4-6" white jumper wires and one of the 198" supply wires from parts bag.
- B) Connect each 6" black jumper wire to 4 black socket wires using provided connectors. Repeat for white wires.
- C) Connect the 4 black jumper wires to the supply wire using provided connectors. Repeat for white wires.

CAUTION: Make sure all wires are stripped 5/8" (16 mm) and no loose wire strands are outside the connectors. As an added precaution, slightly tug on each wire to ensure that each on is secure inside wire connector and then wrap the connection with electrical tape.

- 8) Slip safety cable, 50" jumper wire and supply wire through threaded pipe inside column (E).
- 9) Apply a small amount of thread locking compound to threaded pipe at bottom of column (E) and screw into hickey (B). Make sure all wires are tucked into body (DD) and do not get pinched or twisted during assembly.
- 10) 16) Secure bottom of middle tier arms in place using ball knobs (GG).
- 11) Assemble arms (AA) to body (BB) at top of column (E) using lockwashers and hexnuts (see Fig. 2A). Tighten hexnuts using provided wrench.

12) TOP TIER WIRING

- D) Take remaining 2 black, remaining 2 white jumper wires and remaining 198" supply wire from parts bag.
- E) Connect each 6" black jumper wire to 4 black socket wires using provided connectors. Repeat for white wires.
- F) Connect 2-6" black jumper wire, 50" black jumper wire, remaining supply wire using provided connectors. Repeat for white wires.

CAUTION: Make sure all wires are stripped 5/8" (16 mm) and no loose wire strands are outside the connectors. As an added precaution, slightly tug on each wire to ensure that each on is secure inside wire connector and then wrap the connection with electrical tape.

- 13) Slip safety cable and both supply wires through threaded pipe inside column (K).
- 14) Apply a small amount of thread locking compound to threaded pipe at bottom of column (K) and screw into hickey (G). Make sure all wires are tucked into body (BB) and do not get pinched or twisted during assembly.

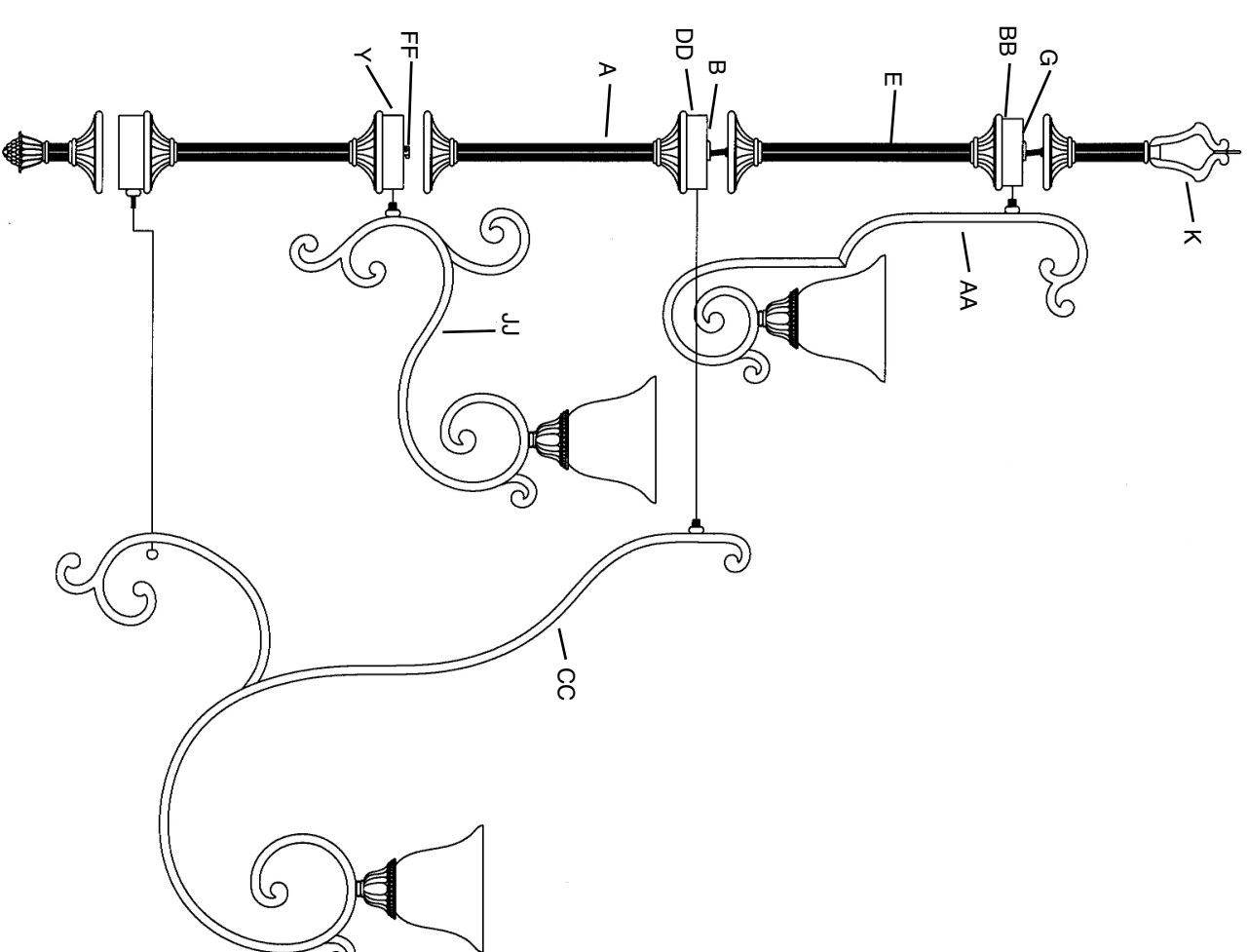

MEANS OF SUPPORT MUST BE ERRECTED ABOVE OUTLET BOX. BELOW IS ONE SUGGESTED METHOD FOR JOIST 16" ON CENTER WITH FIXTURE CENTERED BETWEEN JOISTS, AS SHOWN

- 15) To erect means of support four pieces of lumber will be required (not included). Two 2x4's at min. of 19" long. Two 1x4's at min. 9 1/4" long.
- 16) Lay one 2x4 on flat surface suitable and stable for nailing.
- 17) Lay the two 1x4's on 2x4 allowing 1/2" gap between ends of 1x4's at center.
- 18) Lay remaining 2x4 on top of 1x4's and nail pieces together using 3 1/8" long 12d nails (not included) on center at approximately 3" from each end.
- 19) Turn assembled lumber over and nail two more nails in at approximately 6" from each end.
- 20) Turn off power.
- 21) If fixture is provided with a safety cable it must pass through outlet box. Drill 3/16" diameter hole in outlet box if no other holes are available.
- 22) Remove knockout in top of outlet box.
- 23) Align hole in mounting strap (D) with gap between 1x4's and secure to 2x4's using provided #10 sheet metal screws (Z).
- 24) In area above outlet box lay assembled lumber from steps 1-5 over ceiling joist (with mounting strap down) aligning gap between 1x4's with knockout removed in outlet box.
- 25) Screw hexnut (H) onto threaded rod (P).
- 26) Slip ground lug (F) and lockwasher (J) onto threaded rod (P).
- 27) Thread screw collar loop (L) onto threaded rod (P) until threaded pipe is flush with hole on lower side of screw collar loop or threaded rod bottoms out.
- 28) Secure screw collar loop (L) in place by tightening hexnut (H) down against ground lug (F), lockwasher (J) and screw collar loop.
- 29) Temporarily slip canopy (M) over screw collar loop (L). Approximately one half of the screw collar loop exterior threads should be exposed below canopy.
- 30) Temporarily screw threaded ring (N) onto screw collar loop (L).
- 31) In area above outlet box pull up on threaded rod (P) until canopy is snug against ceiling.
- 32) Slide flat washers (X) down threaded rod and against top of lumber assembly. Secure in place by running jam nuts (Q & R) down against flat washer.
- 33) Secure lumber assembly in place by toe-nailing or other means.
- 34) Tighten anti-rotational screw located next to center hole inside mounting strap (D) with provided wrench.
- 35) Remove threaded ring (N) and canopy (M).

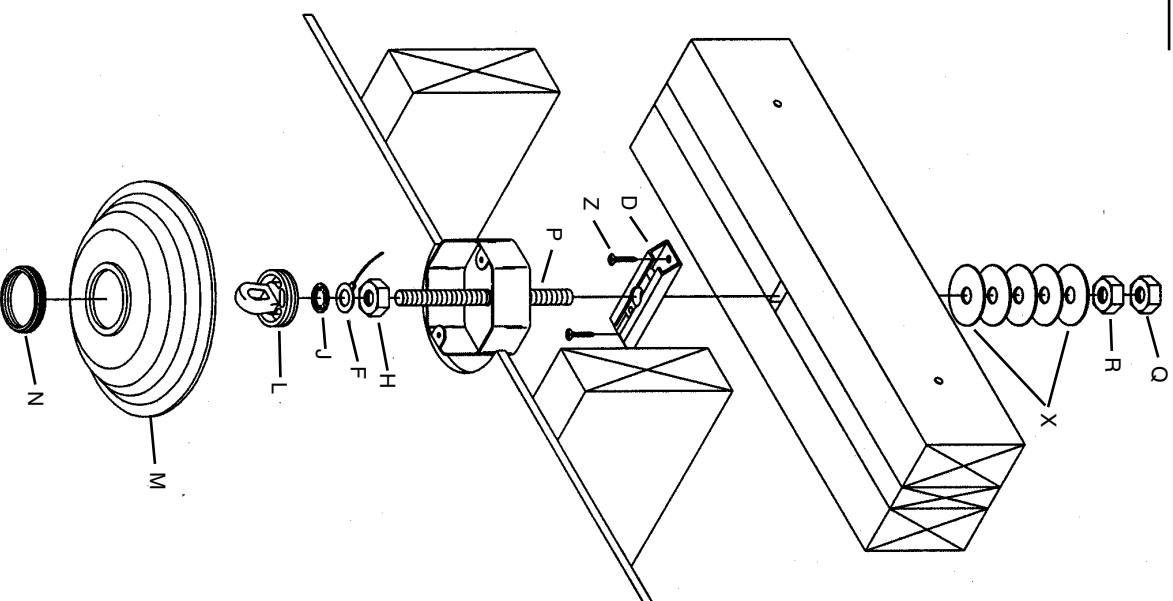
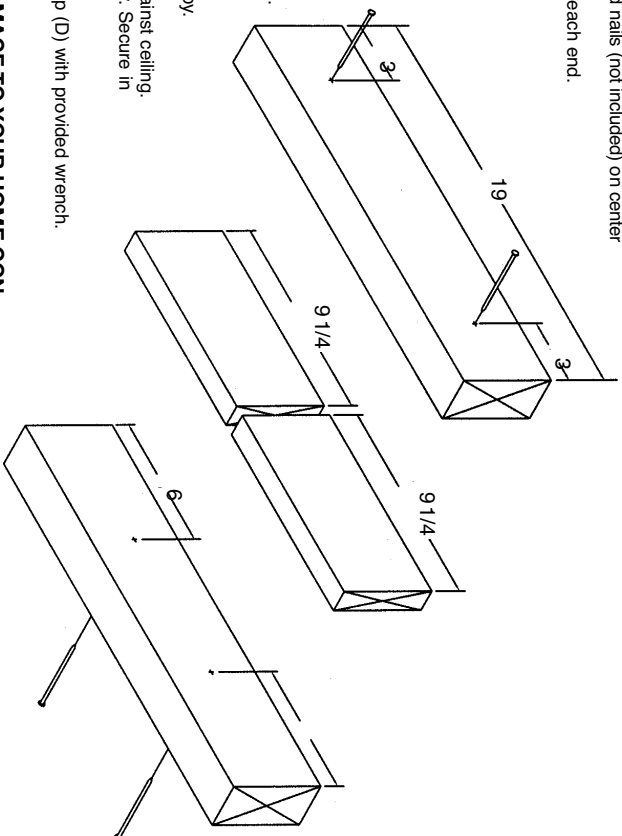

2

- 36) Attach chain to fixture. Fixture loop has one chain link factory installed. Chain has one locking link at each end. Unthread coupling on locking link and slip over link attached to loop. Screw coupling closed.
- 37) Slip threaded ring (N) then canopy (M) onto chain (W).
- 38) Attach chain (with fixture connected) to bottom of screw collar loop following the same procedure as in step 1.
- 39) Weave electrical wire, ground wire and safety cable through chain links no more than 3 inches apart.
- 40) Pass electrical wire ground wire and safety cable through threaded ring (N), canopy (M), one of the slots in screw collar loop (L) and into outlet box.
- 41) Pass safety cable through hole (See sec. 1)
- 42) In area above outlet box wrap cable around one of the 2 x 4's erected in section 1 and pull cable taut.
- 43) Secure cable with (2) clamps provided.

NOTE: Cable is not to be used as the only means of fixture support. Please follow independent mounting instructions completely.

- 44) Connect fixture ground wire and ground wire attached to threaded rod (B or P) to outlet box ground wire with wire connector (not provided). Never connect ground wire to black or white power supply wires.
- 45) Make wire connections (connectors not provided). Reference chart below for correct connections and wire accordingly.

Connect Black or Red Supply Wire to:	Connect White Supply Wire to:
Black	White
*Parallel cord (round & smooth)	*Parallel cord (square & ridged)
Clear, Brown, Gold or Black without tracer	Clear, Brown, Gold or Black with tracer
Insulated wire (other than green) with copper conductor	Insulated wire (other than green) with silver conductor

*Note: When parallel wires (SPT I & SPT II) are used. The neutral wire is square shaped or ridged and the other wire will be round in shape or smooth (see illus.)



- 46) Raise canopy (M) to ceiling.
- 47) Secure canopy (M) in place by screwing threaded ring (N) onto screw collar loop (L)
- 48) Screw bottom trim onto bottom of fixture.
- 49) Slip glass over socket at end of arm and secure in place with socket ring.

3

