

Ceiling or Inside Wall Exhaust Fan

MODEL: 8310

DESCRIPTION

- For ventilation of kitchens up to 90 sq. ft. or other rooms up to 225 sq. ft.
- Extension-type hanger bars are included for 16" or 24" O.C. joists or studs.
- Housing with duct collar is 3¹/₁₆" x 11⁵/₈" x 3³/₁₆".
- Installs in ceiling or in 2" x 4" wall application; discharge through 3¹/₄" x 10" duct.
- Motor quietly drives electronically balanced impeller type fan blade.
- Silver anodized aluminum grille, fastens with plated thumbscrew that is adjustable for ceiling or wall thickness.
- Switch operated – turn fan ON and damper opens automatically, damper shuts tight when fan is OFF.
- Pre-wired outlet box – plug-in receptacle.
- Refer to NuTone's catalog for a complete line of accessories to effectively adapt this Exhaust Fan to your construction requirements.
- Suitable for use with solid-state speed controls.

DESIGN FEATURES

- Air Delivery:** 180 CFM at 0.10" S.P.
Sound Level: 5.5 Sones.
Dimensions: **Housing:** 11⁵/₈" x 13¹/₁₆" x 3³/₁₆".
Grille: 11" diameter.
Material & Finish: **Housing:** Cold rolled steel, baked enamel.
Grille: Aluminum, silver anodized.
Motor: Fully encased, plug-in, impedance protected, 120vAC, 60 Hz, 1550 RPM, 1/54 HP, 0.78 amp, 55 watts, 5/16" diameter shaft.
Fan Blade: One-piece 0.040 aluminum, 8" diameter, 6-leaf, 1²⁹/₃₂" pitch, 5/16" hub I.D.
Duct Size: 3¹/₄" x 10".

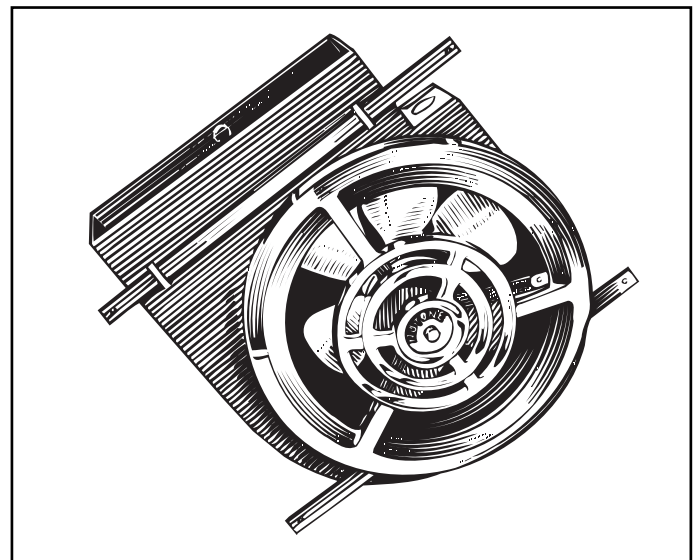

INSTALLATION

- Housing is installed in ceiling or 2" x 4" wall during the rough-in stage of construction. Adjustable hanger bars slide through built-in tabs on housing for 16" – 24" O.C. joists.
- The knockouts in prewired outlet box allow for connection of house leads to be made from either above or from the end of the unit. Motor assembly features three (3) grommeted brackets that fasten into the ends of three (3) mounting studs on the housing. Grille screw will accommodate plaster or drywall thickness variances. Installation Instructions included with each unit.
- Install at least 5 feet above floor or install above counter or major appliance.

ARCHITECT'S SPECIFICATIONS

Exhaust Fan shall be Model 8310 as manufactured by NuTone according to listed specifications. Fan shall ventilate at 180 CFM at 0.10" S.P. at a sound level of 5.5 sones. Housing shall measure 11⁵/₈" x 13¹/₁₆" x 3³/₁₆" deep and connect to 3¹/₄" x 10" duct.



CERTIFIED TEST DATA

HVI-2100 CERTIFIED RATINGS comply with new testing technologies and procedures prescribed by the Home Ventilating Institute, for off-the-shelf products, as they are available to consumers. Product performance is rated at 0.1 in. static pressure, based on tests conducted in AMCA's state-of-the-art test laboratory. Sones are a measure of humanly-perceived loudness, based on laboratory measurements. This NuTone model is listed by Underwriters' Laboratories Inc. and Certified by the Canadian Standards Association (CSA.)

The air delivery of a ventilating system may be determined by:

1. Determine the equivalent duct length for each 90 degree elbow by adding one foot of duct length for each inch of duct diameter, i.e., a 4 inch diameter duct elbow equals 4 feet equivalent duct length and an 8 inch diameter duct elbow equals 8 feet equivalent duct length.
2. Add the total straight length of duct and the equivalent length for each elbow to obtain the total equivalent duct length.
3. Locate the intersection of the fan performance curve and the total equivalent duct length curves and draw a vertical line down to the CFM scale and read the system air performance.
(NOTE: 3/4" x 10" duct equals 6 inch diameter duct.)

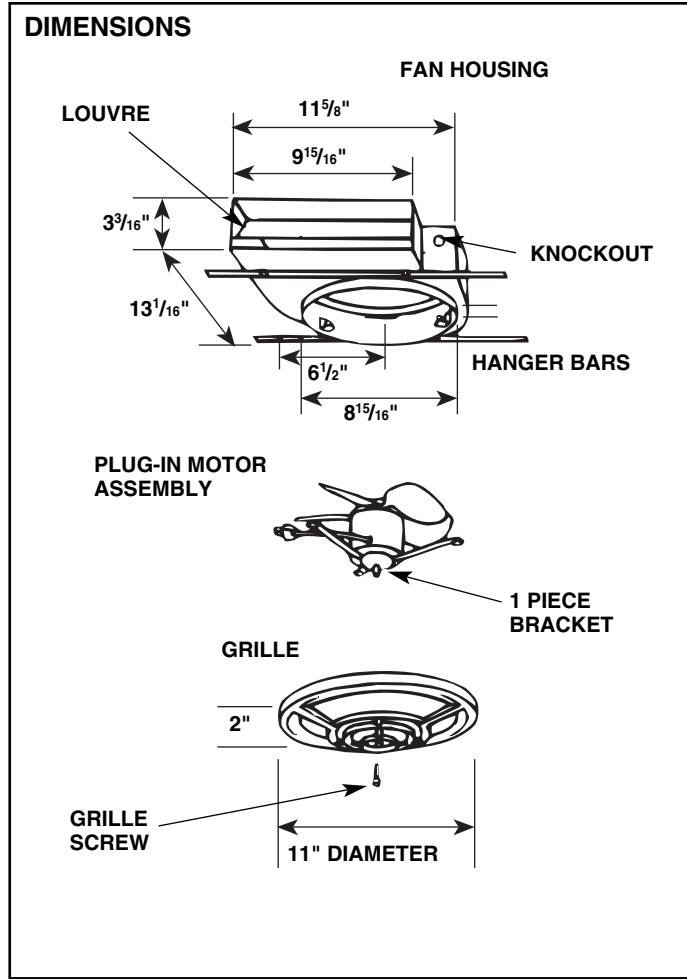

AIR PERFORMANCE CURVE
(6 In. (3/4 x 10) Duct to 10 Foot Lengths)

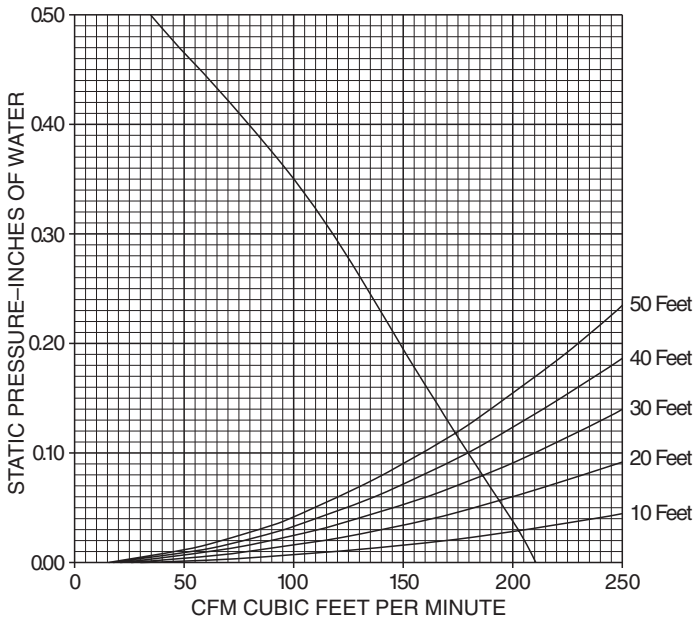

STATIC PRESSURE INCHES OF WATER	0.05	0.1	0.15	0.2	0.25	0.3	0.35	0.4	0.45
CFM	197	181	165	149	135	118	100	-	-

Product specifications subject to change without notice.