

Type _____
 -09
 P2939

Catalog No.	Finish	Lamping	Dimensions (Inches)			
	Brushed Nickel		A	B	C	D
P2939	-09	1(m) 100w	8	6-3/4	9-1/4	3-1/2

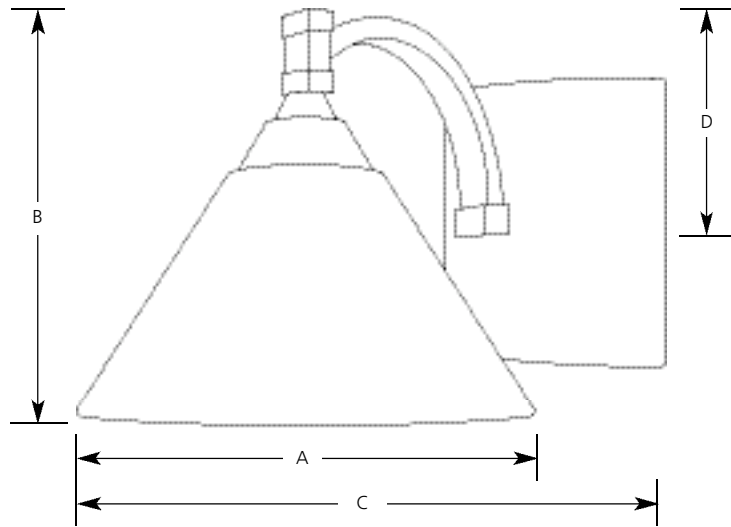

Specifications:

General

- Etched white opal glass conical shade
- Can be mounted in "up" or "down" position
- Steel construction
- Plated brushed nickel finish
- Companion chandeliers, hall & foyer. Close to ceiling, and mini-pendant units

Electrical

- Ceramic medium based socket
- Threaded socket ring secures glass
- Pre-wired

Labeling

- UL-CUL listed

Mounting

- Wall mounted
- Canopy covers a standard recessed 4" octagonal outlet box
- Mounting strap for outlet box included