

INSTRUCTIONS: Builder Series Line Voltage Bar Lights
Model: BA-BX-1, BA-BX-2, BA-BX-3, BA-BX-4

CAUTION:

- Read all instructions before installing.
- Always turn off power at fuse box prior to installation to prevent electrical shock.
- For display wall or under cabinet only. Not intended for ceiling use.
- For installation by a qualified electrician.
- System is intended for installation in accordance with National Electric Code, and local regulations. Consult with local inspector to assure compliance.
- Keep away from combustible materials such as plastic or paper products.
- Do not touch cover when light is on. Do not operate with missing or damaged lens.
- All wires must be contained.

Wiring and Installation:

1. Remove the thumbscrews and glass lens.
2. The rear cover and reflector are one-piece. To remove: Press firmly on the rear cover down and back to release from the sheet metal tab (see diagram below). Then pivot the assembly up to expose wiring compartment.
3. Open a convenient knock out hole in the body of the fixture, and install the non-metallic sheathed cable connector supplied with the fixture. Allow approx 1 ½" of wire to enter the fixture body.
4. Connect fixture wires with corresponding color supply wires (ground wire may be green or bare wire). Trim ¼" of insulation from the building wires and connect by pushing into one of the available holes in the connector.
5. Tuck wires connections neatly in the wiring compartment.
6. Replace the rear cover/reflector assembly.
7. Mount the fixture to the surface using the template and screws provided, then replace lens.

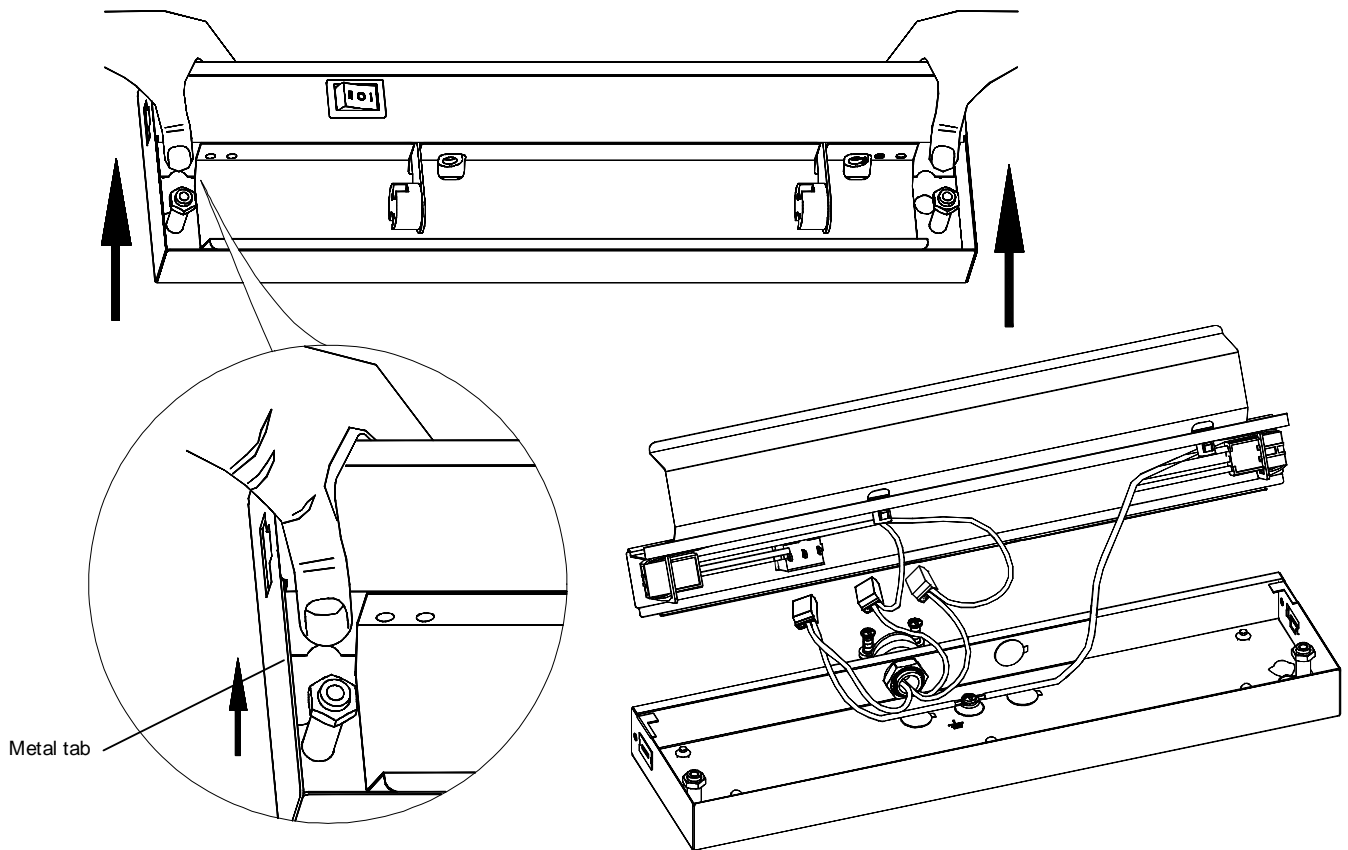

Wiring of multiple units:

In addition to hard wiring, components are provided to allow fixtures to be joined through surface wiring.

Note: The total wattage of all connected fixtures should not exceed 700 watts.

End to End Connection (I-connector included) :

The "I" connector allows two fixtures to be butted end to end.

1. Pry out the plastic covers concealing the female connection ports at the end of the fixtures.
2. The "I" connector will only fit in the correct orientation.
3. Insert one end of the "I" connector into the fixture. Slide the next fixture to abut the original.
4. Secure position by mounting fixtures to the surface.

Interconnecting Fixtures with Jumper Wire (Sold Separately) :

A surface mount jumper wire allows multiple units to be linked through surface wiring (see diagram below).

1. Pry out the plastic covers concealing the female connection ports at the end of the fixtures.
2. Jumper wire ends will only fit in the correct orientation.
3. Insert the ends of the connectors into each fixture.
4. Jumper wires use metal strain relief cover brackets. Slide the cover bracket over the connector. Position bracket and fixture holes and secure with screw provided.
5. Wrap excess wire with nylon wire ties.

Cord and Plug Use (Sold Separately):

Install the connector end of plug in line cord as described above (using a Jumper wire).

TO RE-LAMP

- Turn off fixture and allow it to cool before replacing lamp.
- For use with Xenon (not tungsten halogen) G8 bi-pin 120 Volt 25 Watt lamps.
 1. Remove the lens to expose the lamps.
 2. Withdraw the lamp by pulling away from the ceramic socket base.
 3. Re-lamping is the reverse procedure.

