

## INSTALLER/CONSUMER SAFETY INFORMATION

**PLEASE READ THIS MANUAL  
BEFORE INSTALLING AND  
USING APPLIANCE**

### **WARNING!**

**IF THE INFORMATION IN THIS  
MANUAL IS NOT FOLLOWED  
EXACTLY, A FIRE OR EXPLO-  
SION MAY RESULT CAUSING  
PROPERTY DAMAGE, PER-  
SONAL INJURY OR LOSS OF  
LIFE.**

### **FOR YOUR SAFETY**

**Installation and service must  
be performed by a qualified  
installer, service agency or  
the gas supplier.**

### **WHAT TO DO IF YOU SMELL GAS:**

- Do not try to light any appliance.
- Do not touch any electric switch;  
do not use any phone in your  
building.
- Immediately call your gas  
supplier from your neighbor's  
phone. Follow the gas suppliers  
instructions.
- If you cannot reach your gas  
supplier call the fire department.

**DO NOT STORE OR USE  
GASOLINE OR OTHER FLAM-  
MABLE VAPORS AND LIQUIDS  
IN THE VICINITY OF THIS OR  
ANY OTHER APPLIANCE.**

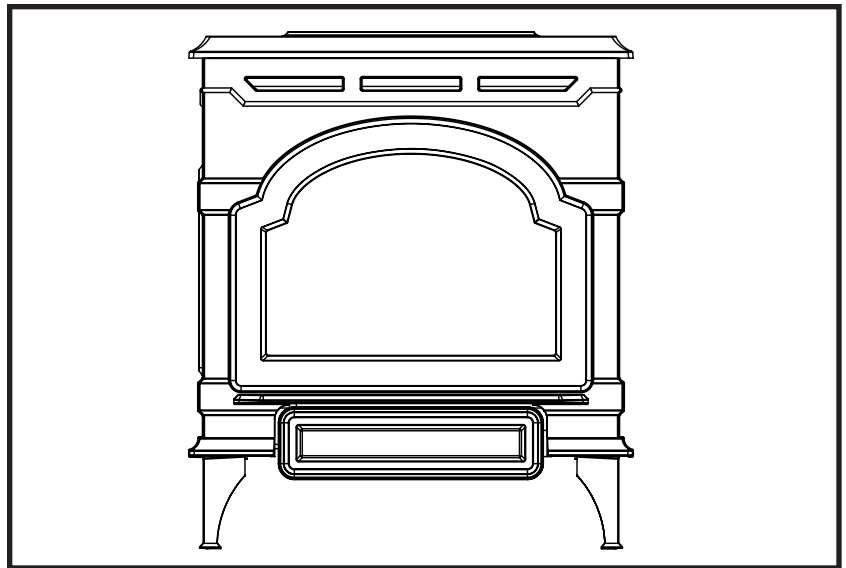
This appliance may be installed in  
an after market permanently located  
manufactured (mobile) home where not  
prohibited by local codes.

This appliance is only for use with the  
type of gas indicated on the rating plate.

This appliance is not convertible for use  
with other gases unless a certified kit is  
used.



# Oxford Direct Vent / Natural Vent Gas Heater Models: OXDV30NV



## Homeowner's Installation and Operating Manual



**INSTALLER: Leave this manual with the appliance.  
CONSUMER: Retain this manual for future reference.**

# Table of Contents

**PLEASE READ THE INSTALLATION & OPERATING INSTRUCTIONS BEFORE USING APPLIANCE.**

**Thank you and congratulations on your purchase of an MHSC stove.**

**IMPORTANT: Read all instructions and warnings carefully before starting installation. Failure to follow these instructions may result in a possible fire hazard and will void the warranty.**

<b>Installation &amp; Operating Instructions</b>	General Information.....	3
	Requirements for the Commonwealth of Massachusetts.....	4
	Stove Dimensions .....	5
	Installation Requirements.....	6
	Locating the Stove.....	6
	Clearance Requirements.....	6
	Parallel & Corner Installation.....	7
	Wall and Ceiling Clearances .....	7
	Hearth Requirements .....	7
	Gas Specifications.....	8
	Gas Inlet and Manifold Pressures .....	8
	High Elevations .....	8
	Horizontal Termination - Direct Vent ONLY .....	8
	Vertical Termination - Direct Vent ONLY.....	9
	Vent Termination Clearances .....	9
	General Venting Information - Termination Location .....	11
	Termination Clearances.....	12
	Venting Requirements - Natural Vent ONLY .....	12
	Venting Requirements and Options - Direct Vent ONLY .....	13
	Install the Optional Fan .....	14
	Venting System Assembly - Direct Vent.....	15
	Install Vent Adapter Pipe (MHSC Vent Components).....	15
	Install Vent Adapter Pipe (Simpson Dura-Vent Components).....	16
	Side Wall Termination Assembly .....	15
	Vent Termination Below Grade.....	18
	Vertical (Through the Roof) Vent Assembly.....	18
	Venting System Assembly - Natural Vent.....	19
	Install the Vent Pipe.....	19
	Install the Log Set.....	20
	Connect Gas Supply Line.....	20
	Burner Information.....	21
	Air Shutter Adjustment & Instructions.....	21
	Complete the Assembly.....	22
	Install ON/OFF Switch.....	22
	Thermostat Connection (Optional).....	23
	Install the Front and Top Plates.....	23
<b>Operation</b>	Your First Fire.....	24
	Pilot and Burner Information.....	24
	Flame & Temperature Adjustment .....	24
	Flame Characteristics.....	24
	Lighting and Operating Instructions.....	25
	Troubleshooting - SIT NOVA 820 Gas Control System.....	26
	Fuel Conversion Instructions.....	27
<b>Maintenance</b>	Annual System Inspection.....	30
	Logset and Burner/Cleaning and Inspection.....	30
	Care of Cast Iron.....	30
	Cleaning the Glass .....	30
	Glass Replacement.....	30
	Gasket Replacement.....	31
	Inspect the Vent System Annually.....	31
	Check the Gas Flame Regularly .....	31
	Stove Disassembly.....	31
	Wiring Diagram.....	32
<b>Replacement Parts</b>	.....	33
<b>Optional Accessories</b>	.....	35
<b>Warranty</b>	.....	39
<b>Energide</b>	.....	40

## General Information

The Oxford Direct Vent/Natural Vent Room Heater, Model No. OXDV30NV, is a vented gas appliance listed to the ANSI standard Z21.88-2009 and CSA-2.33-2009 for Vented Room Heaters, and CSA 2.17-M91, Gas-Fired Appliances For Use at High Altitudes.

The installation of the Oxford Direct Vent/Natural Vent Room Heater must conform with local codes, or in the absence of local codes, with National Fuel Gas Code, ANSI Z223.1/NFPA 54 — latest edition and CSA B-149.1 Installation Code. (EXCEPTION: Do not derate this appliance for altitude. Maintain the manifold pressure at 3.5" w.c. for Natural Gas and 10.0" w.c. for LP gas at maximum input.)

This appliance is only for use with the type of gas indicated on the rating plate. This appliance is not convertible for use with other gases unless a certified kit is used.

**Installation and replacement of gas piping, gas utilization equipment or accessories, and repair and servicing of equipment shall be performed only by a qualified agency, preferably NFI or WETT (Canada) certified. The term "qualified agency" means any individual, firm, corporation, or company that either in person or through a representative is engaged in and is responsible for (a) installation or replacement of gas piping, or (b), the connection, installation, repair, or servicing of equipment, who is experienced in such work, familiar with all precautions required, and has complied with all the requirements of the authority having jurisdiction.**

**The Oxford Direct Vent/Natural Vent Room Heater should be inspected before use and at least annually by a qualified service agency. It is imperative that control compartments, burners, and circulating air passageways of the appliance be kept clean.**

The Oxford Direct Vent/Natural Vent Room Heater and its individual shut-off valve must be disconnected from the gas supply piping during any pressure testing of that system at test pressures in excess of 1/2 psig (3.5 kPa).

The Oxford Direct Vent/Natural Vent Room Heater must be isolated from the gas supply piping system by closing its individual manual shutoff valve during any pressure testing of the gas supply piping system at test pressures equal to or less than 1/2 psig.

'Direct Vent' describes a sealed combustion system in which incoming outside air for combustion and outgoing exhaust enter and exit through two separate concentric passages within the same sealed vent system. The system does not use room air to support combustion. The Direct Vent system permits the gas appliance to be vented directly to the outside atmosphere through the side of the house or vertically through the roof. Conventional venting systems (Natural Vent) take air from the room for combustion and vent the exhaust vertically through the roof to the atmosphere.

This appliance is approved for bedroom installations in the U.S. and Canada.

This appliance may be installed in an aftermarket\* manufactured (mobile) home, where not prohibited by state or local codes.

**WARNING: Operation of this heater when not connected to a properly installed and maintained venting system can result in carbon monoxide (CO) poisoning and possible death.**

The Oxford Direct Vent/Natural Vent Room Heater, when installed, must be electrically grounded in accordance with local codes or, in the absence of local codes, with the National Electrical Code ANSI/NFPA 70, (latest edition), or of the current Canadian Electrical Code C22.1.

**Due to high temperatures this appliance should be located out of traffic and away from furniture and draperies.**

**WARNING: This appliance is hot while in operation. Keep children, clothing, and furniture away. Contact may cause burns or ignition of combustible materials.**

**Children and adults should be alerted to the hazards of high surface temperatures and should stay away to avoid burns or clothing ignition. Young children should be carefully supervised when they are in the same room as the appliance.**

**Clothing or other flammable materials should not be placed on or near the appliance.**

**Any safety screen, glass or guard removed for servicing an appliance must be replaced prior to operating the appliance.**

**The appliance area must be kept clear and free from combustible materials, gasoline, and other flammable vapors and liquids.**

**The flow of combustion and ventilation air must not be obstructed. The installation must include adequate accessibility and clearance for servicing and proper operation.**

**WARNING: Do not operate the Room Heater with the glass panel removed, cracked or broken. Replacement of the panel should be done by a licensed or qualified service person.**

**Do not use this appliance if any part has been under water. Immediately call a qualified service technician to inspect the appliance and to replace any part of the control system and any gas control which has been under water.**

**Do not burn wood, trash or any other material for which this appliance was not designed. This appliance is designed to burn either natural gas or propane only.**

**This gas appliance must not be connected to a chimney flue serving a separate solid-fuel burning appliance.**

**CAUTION: Label all wires prior to disconnection when servicing controls. Wiring errors can cause improper and dangerous operation.**

**Verify proper operation after servicing.**

**Proposition 65 Warning:** Fuels used in gas, woodburning or oil fired appliances, and the products of combustion of such fuels, contain chemicals known to the State of California to cause cancer, birth defects and other reproductive harm.

California Health & Safety Code Sec. 25249.6

\* **Aftermarket:** Completion of sale, nor for purpose of resale, from the manufacturer.

## Installation Requirements

### Requirements for the Commonwealth of Massachusetts

All gas fitting and installation of this heater shall only be done by a licensed gas fitter or licensed plumber.

For all side wall horizontally vented gas fueled equipment installed in every dwelling, building or structure used in whole or in part for residential purposes, including those owned or operated by the Commonwealth and where the side wall exhaust vent termination is less than seven (7) feet above finished grade in the area of the venting, including but not limited to decks and porches, the following requirements shall be satisfied:

#### Installation of Carbon Monoxide Detectors

At the time of installation of the side wall horizontal vented gas fueled equipment, the installing plumber or gas fitter shall observe that a hard wired carbon monoxide detector with an alarm is installed on each additional level of the dwelling, building or structure served by the side wall horizontal vented gas fueled equipment. It shall be the responsibility of the property owner to secure the services of qualified licensed professionals for the installation of hard wired carbon monoxide detectors.

In the event that the side wall horizontally vented gas fueled equipment is installed in a crawl space or an attic, the hard wired carbon monoxide detector with alarm and battery back-up may be installed on the next adjacent floor level.

In the event that the requirements of this subdivision can not be met at the time of completion of installation, the owner shall have a period of thirty (30) days to comply with the above requirements; provided, however, that during said thirty (30) day period, a battery operated carbon monoxide detector with an alarm shall be installed.

#### Approved Carbon Monoxide Detectors

Each carbon monoxide detector as required in accordance with the above provisions shall comply with NFPA 720 and ANSI/UL 2034 listed and IAS certified.

#### Signage

A metal or plastic identification plate shall be permanently mounted to the exterior of the building at a minimum height of eight (8) feet above grade directly in line with the exhaust vent terminal for the horizontally vented gas fueled heating appliance or equipment. The sign shall read, in print size no less than one-half (1/2) inch in size, "**GAS VENT DIRECTLY BELOW, KEEP CLEAR OF ALL OBSTRUCTIONS**".

### Inspection

The state or local gas inspector of the side wall horizontally vented gas fueled equipment shall not approve the installation unless, upon inspection, the inspector observes carbon monoxide detectors and signage installed in accordance with the provisions of 248 CMR 5.08(2)(a)1 through 4.

### Exemptions

The following equipment is exempt from 248 CMR 5.08(2)(a)1 through 4:

- The equipment listed in Chapter 10 entitled "Equipment Not Required To Be Vented" in the most current edition of NFPA 54 as adopted by the Board; and
- Product Approved side wall horizontally vented gas fueled equipment installed in a room or structure separate from the dwelling, building or structure used in whole or in part for residential purposes.

## MANUFACTURER REQUIREMENTS

### Gas Equipment Venting System Provided

When the manufacturer of Product Approved side wall horizontally vented gas equipment provides a venting system design or venting system components with the equipment, the instructions provided by the manufacturer for installation of the equipment and the venting system shall include:

- Detailed instructions for the installation of the venting system design or the venting system components; and
- A complete parts list for the venting system design or venting system.

### Gas Equipment Venting System NOT Provided

When the manufacturer of a Product Approved side wall horizontally vented gas fueled equipment does not provide the parts for venting the flue gases, but identifies "special venting systems", the following requirements shall be satisfied by the manufacturer:

- The referenced "special venting system" instructions shall be included with the appliance or equipment installation instructions; and
- The "special venting systems" shall be Product Approved by the Board, and the instructions for that system shall include a parts list and detailed installation instructions.

A copy of all installation instructions for all Product Approved side wall horizontally vented gas fueled equipment, all venting instructions, all parts lists for venting instructions, and/or all venting design instructions shall remain with the appliance or equipment at the completion of the installation.

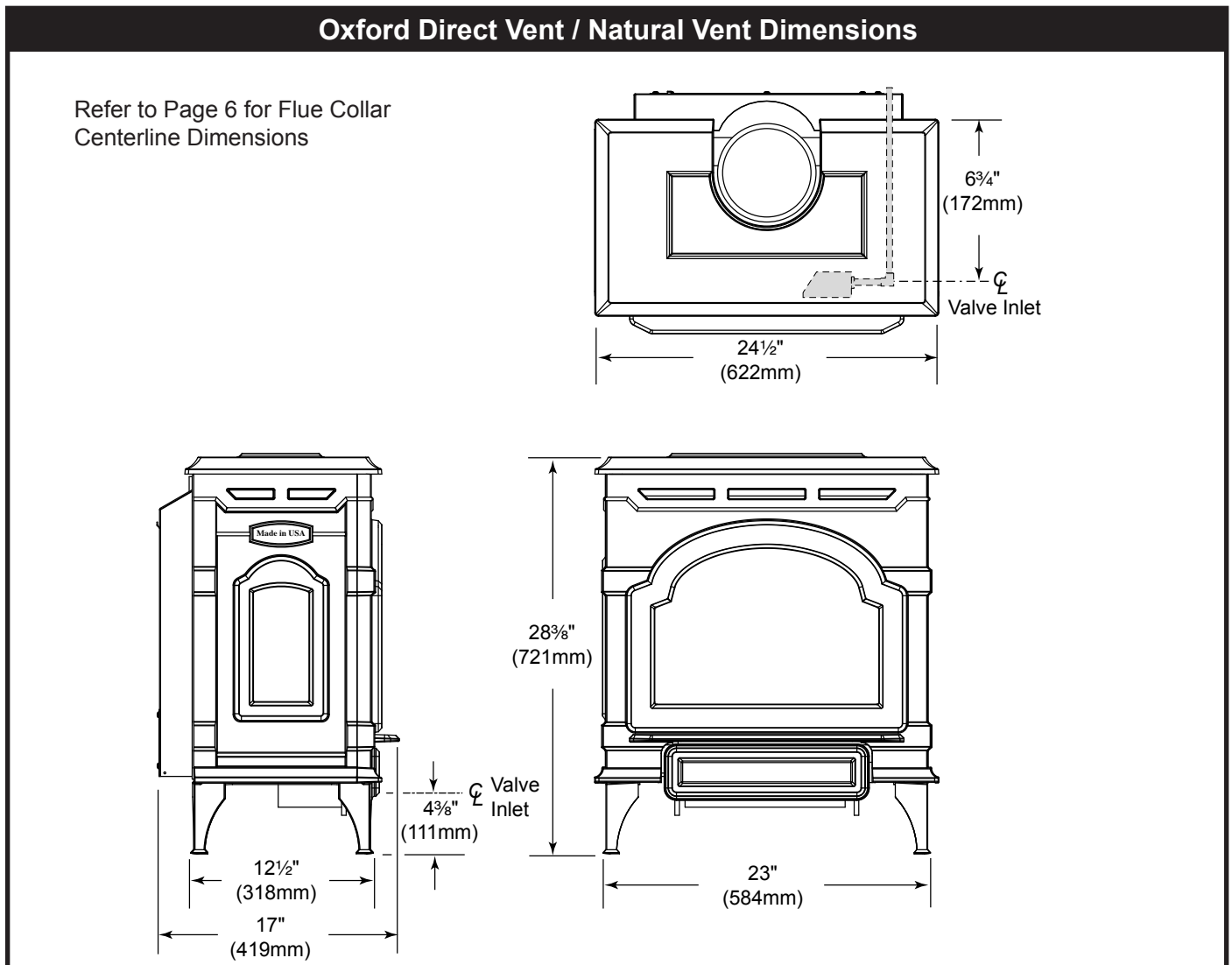


Fig. 1 Oxford dimensions.

### Attention

The Oxford stove is shipped from the factory as a Direct Vent Gas Heater. This heater may be converted into a Natural Vent unit in the field. If a Natural Vent heater is desired, the FSDHAG Draft Hood must be directly installed to the top of the unit according to the installation instructions. The Draft Hood Adapter is available in the 7FSDHASK stove kit or as a separate item.

When the stove is converted to Natural Vent, it uses 4" vent pipe. For aesthetic purposes the MHSC direct vent system may be used up to the ceiling.

## Installation Requirements

The installation must conform with local codes or, in the absence of local codes, with the National Fuel Gas Code, ANSI Z223.1/NFPA 54 - latest edition. (EXCEPTION: Do not derate this appliance for altitude. Maintain the manifold pressure at 3.5" w.c. for Natural Gas, and 10" w.c. for Propane).

In Canada, installation must be in accordance with the current CSA B-149.1 Installation Codes and/or local codes.

The installation should be done by a qualified service person who is familiar with the building codes and installation techniques appropriate for your area to accomplish a safe and effective installation.

Your dealer or your local gas supplier will be able to refer a qualified service person.



**WARNING:** Due to high temperatures, the HEATER should be located out of traffic and away from furniture and draperies.

The surface of the Heater is hot when it is in use. Young children should be watched carefully when they are in the same room when the Heater is in use, and they should be taught to avoid the hot surface. Keep any objects that can burn well away from the Heater, and observe the recommended clearances that follow.

**WARNING**

HOT GLASS WILL CAUSE BURNS.

DO NOT TOUCH GLASS UNTIL COOLED.

NEVER ALLOW CHILDREN TO TOUCH GLASS.

### Locating the Stove

In choosing a location for the stove, consider:

- The location of outside walls;
- Where additional heat is needed;
- Where family members gather most often;
- The vent system requirements.

**NOTE:** We do not recommend the use of wallpaper next to this stove. Over time, radiant heat may cause the wallpaper to shrink, or may adversely affect the binders in the wallpaper adhesive.

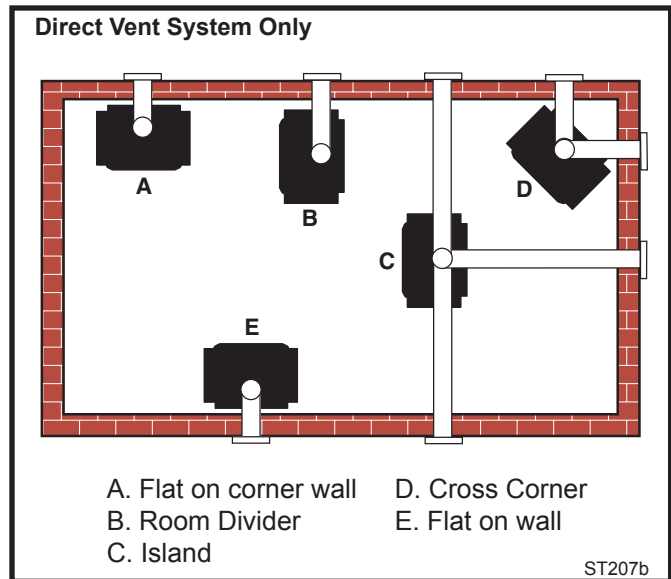


Fig. 2 Possible stove locations.

## Clearance Requirements

### Minimum Clearances to Combustible Materials

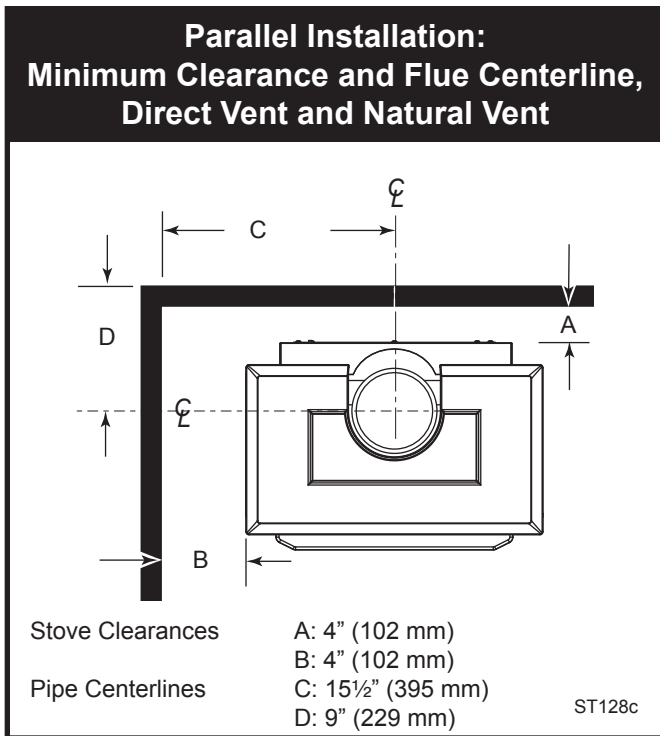
Measure side clearances as shown in Figures 5 and 6 from the outer edge of the cast iron stove top. Measure rear clearances from the outermost surface of the steel rear skirt.

The heater is approved for installation into an alcove constructed of combustible materials to the dimensions and clearances shown on the next page.

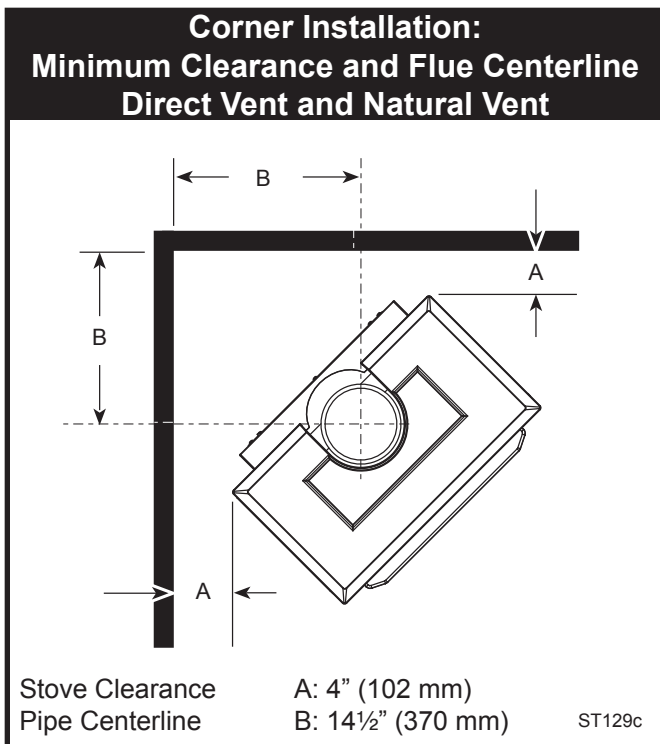
The same clearances apply in a standard parallel installation.

**Warning:**

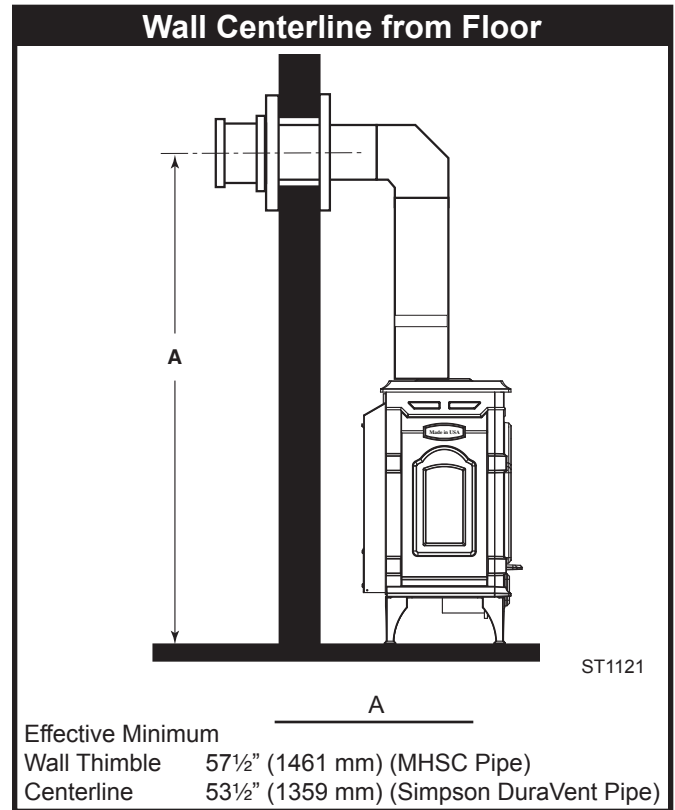
- Always maintain required clearances (air spaces) to nearby combustibles to prevent fire hazard. Do not fill air spaces with insulation. All venting components must maintain a 1" (25 mm) clearance to combustible materials. Maintain a 6" (150 mm) clearance when using a single wall pipe.
- The gas appliance and vent system must be vented directly to the outside of the building and never be attached to a chimney serving a separate solid fuel or gas-burning appliance. Each direct vent appliance must use its own separate vent system. Common vents are prohibited.
- Refer to the manufacturer's instructions included with the venting system for complete installation procedures.



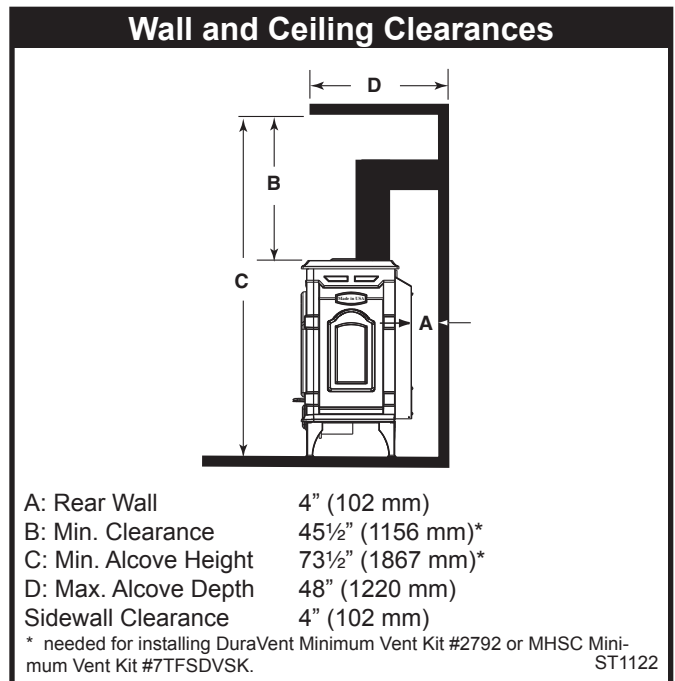
**Fig. 3** Parallel installation, minimum back and side clearances and flue centerlines.



**Fig. 4** Corner installation, minimum corner clearances and flue centerline.



**Fig. 5** Minimum wall thimble centerline.



**Fig. 6** Dimensions and clearances to ceiling or alcove.

**Hearth Requirements**

The heater must be installed on rigid flooring. When the heater is installed directly on any combustible surface other than wood flooring, a metal or wood panel extending the full width and depth of the unit must be used as the hearth. There are no other hearth requirements.

Gas Specifications				
Model	Fuel	Gas Control	Max. Input BTU/h	Min. Input BTU/h
2465	Nat	Millivolt	28,000	20,000
2466	Prop	Millivolt	28,000	19,000

Weight: Fully assembled; 202 lbs.

Gas Inlet and Manifold Pressures		
	Natural	LP (Propane)
Inlet Minimum	5.5" w.c.	11.0" w.c.
Inlet Maximum	14.0" w.c.	14.0" w.c.
Manifold Pressure	3.5" w.c.	10.0" w.c.

**Oxford Direct Vent/Natural Vent  
Certified to:  
ANSI Z21.88b-2008 / CSA 2.33b-2008  
Vented Gas Fireplace Heaters**

The installation of your stove must conform with local codes, or in the absence of local codes, with the National Fuel Gas Code ANSI Z223.1/NFPA 54 - latest edition, or CSA B149.1 Installation code. (EXCEPTION: Do not derate this appliance for altitude up to 4,500 feet (1,370m). Maintain the manifold pressure at 3.5" w.c. for Natural Gas and 10.0" w.c. for LP Gas.

**High Elevations**

Input ratings are shown in BTU per hour and are certified without deration for elevations up to 4,500 feet (1,370m) above sea level. For elevations above 4,500 feet (1,370m) in USA, installations must be in accordance with the current ANSI Z223.1/NFPA 54 and/or local codes having jurisdiction. In Canada, please consult provincial and/or local authorities having jurisdiction for installations at elevations above 4,500 feet (1,370m).

**WARNING:** Improper installation, adjustment, alteration, service or maintenance can cause injury or property damage. Refer to this manual for correct installation and operational procedures. For assistance or additional information consult a qualified installer, service agency, or the gas supplier.

### Horizontal Termination - Direct Vent ONLY

The vent must rise vertically a minimum of 24" (610 mm) off the top of the unit, before the first elbow. The horizontal run may extend up to 20' (6 m) and include a vertical rise of up to 40' (12 m). (Fig. 7) Horizontal termination must also meet the criteria shown in Figures 9 through 11.

- Approved vent systems must terminate above and including the heavy line in Figure 7.
- Two 45° elbows may be substituted for each single 90° elbow.
- With a rise between 2' - 5', one 90° or two 45° elbows may be used.

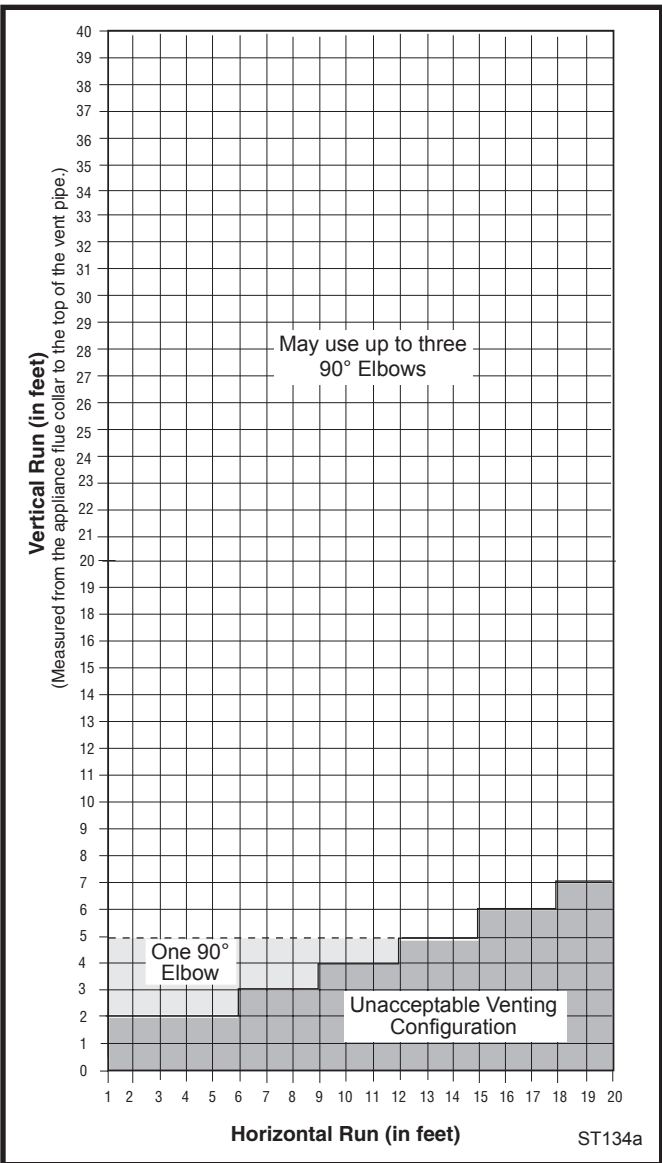


Fig. 7 Horizontal vent termination window.



## Vertical Termination - Direct Vent ONLY

A vertical vent system must terminate no less than 8' (2.44 m) and no more than 40' (12 m) above the appliance flue collar. A 2¼" restrictor plate (supplied) must be used where specified in all vertically terminated vent systems. (Fig. 8) **NOTE: The restrictor plate supplied with the vertical termination should be discarded. Install restrictor plate supplied with stove directly at stove outlet.** A vertically terminated vent system must also conform to the following criteria:

- No more than three 90° elbows may be used.
- Two 45° elbows may be substituted for one 90° elbow. No more than six elbows may be used.
- Vent must rise a minimum of 2 feet before offset is used.
- Termination height must conform to roof clearance as specified in Figure 9.

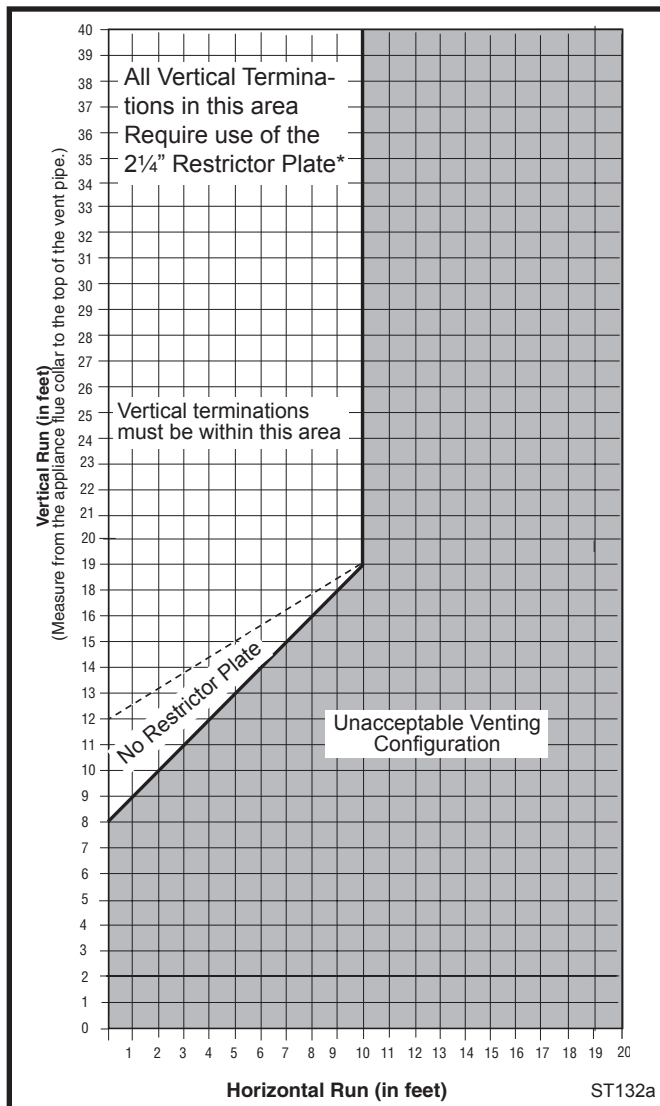


Fig. 8 Vertical vent termination window.

**\*The Restrictor Plate is used on Direct Vent Installations Only**

30005123

## Vent Termination Clearances

When planning the installation, consider the location of the vent terminal and clearances. Some of the most common clearances to keep in mind are shown in Figure 10.

**Important: All vent clearances must be maintained. Check your vent termination clearances against Figures 9 through 11.**

The vent should be placed so that people cannot be burned by accidentally touching the vent surfaces when the stove is operating.

The vent termination should be located where it cannot be damaged by such things as automobile doors, lawn mowers or snowblowers and it should be located away from areas where it could become blocked by snow, etc.

Some considerations are:

- Obstructions or impediments to venting.
- Nearby combustible materials that could come into contact with combustion exhaust gases.
- Other nearby openings {within 12" (305mm)} through which exhaust gas could reenter the building.
- All vegetation within 3' (76mm) that may interfere with the draft.

Other factors that influence where the installation will be sited include the location of outside walls, where additional heat may be desired in the home, where the family members gather most regularly, and perhaps most importantly, the distance limitations of the venting system.



### IMPORTANT Direct Vent Only

- The horizontal termination must not be recessed into the exterior wall or siding.
- Horizontal vent runs must be level toward the vent termination.
- Clearances around the vent termination must be maintained.
- For installations using Simpson DuraVent pipe, parallel installations with minimum wall clearance have restricted access for connecting the Horizontal Vent Cap straps to the vent pipe. See the maker's instructions for recommended installation procedures.

## Venting Termination Clearances

Your stove is approved to be vented either through the side wall, or vertical through the roof.

- **This unit does not require any opening for inspection of vent pipe.**
- **Only MHSC and Simpson DuraVent venting components specifically approved and labelled for this stove may be used.**
- **Minimum clearances between vent pipes and combustible materials is one (1") inch (25 mm), except where stated otherwise.**
- Venting terminals shall not be recessed into a wall or siding.
- Horizontal venting must be installed on a level plane without an inclining or declining slope.

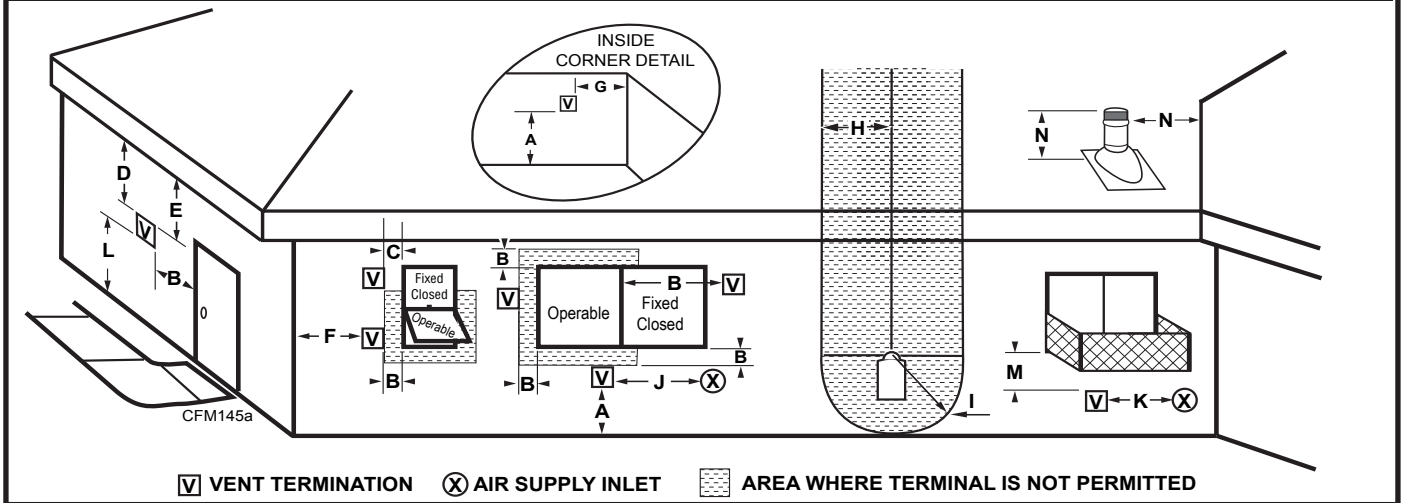
There must not be any obstruction such as bushes, garden sheds, fences, decks or utility buildings within 24" from the front of the termination hood.

Do not locate termination hood where excessive snow or ice build up may occur. Be sure to check vent termination area after snow falls, and clear to prevent accidental blockage of venting system. When using snow blowers, make sure snow is not directed towards vent termination area.

### Location of Vent Termination

It is imperative the vent termination be located observing the minimum clearances as shown on this page.

**General Venting Information - Termination Location**



	Canadian Installations <sup>1</sup>	US Installations <sup>2</sup>
A = Clearance above grade, veranda, porch, deck, or balcony	12" (30cm)	12" (30cm)
B = Clearance to window or door that may be opened	6" (15cm) for appliances < 10,000Btuh (3kW), 12" (30cm) for appliances > 10,000 Btuh (3kW) and < 100,000 Btuh (30kW), 36" (91cm) for appliances > 100,000 Btuh (30kW) appliances > 50,000 Btuh (15kW)	6" (15cm) for appliances < 10,000 Btuh (3kW), 9" (23cm) for appliances > 10,000 Btuh (3kW) and < 50,000 Btuh (15kW), 12" (30cm) for appliances > 50,000 Btuh (15kW)
C = Clearance to permanently closed window	12" (305mm) recommended to prevent window condensation	12" (305mm) recommended to prevent window condensation
D = Vertical clearance to ventilated soffit located above the terminal within a horizontal distance of 2 feet (610mm) from the center line of the terminal	18" (458mm)	18" (458mm)
E = Clearance to unventilated soffit	12" (305mm)	12" (305mm)
F = Clearance to outside corner	see next page	see next page
G = Clearance to inside corner (see next page)	see next page	see next page
H = Clearance to each inside of center line extended above meter/regulator assembly	3' (91cm) within a height of 15' (5m) above the meter/regulator assembly	3' (91cm) within a height of 15' (5m) above the meter/regulator assembly
I = Clearance to service regulator vent outlet	3' (91cm)	3' (91cm)
J = Clearance to nonmechanical air supply inlet to building or the combustion air inlet to any other appliances	6" (15cm) for appliances < 10,000 Btuh (3kW), 12" (30cm) for appliances > 10,000 Btuh (3kW) and < 100,000 Btuh (30kW), 36" (91cm) for appliances > 100,000 Btuh (30kW)	6" (15cm) for appliances < 10,000 Btuh (3kW), 9" (23cm) for appliances > 10,000 Btuh (3kW) and < 50,000 Btuh (15kW), 12" (30cm) for appliances > 50,000 Btuh (15kW)
K = Clearance to a mechanical air supply inlet	6' (1.83m)	3' (91cm) above if within 10' (3m) horizontally
L = Clearance above paved sidewalk or paved driveway located on public property	7' (2.13m)†	7' (2.13m)†
M = Clearance under veranda, porch, deck or balcony	12" (30cm)*	12" (30cm)*
N = Clearance above a roof shall extend a minimum of 24" (610mm) above the highest point when it passes through the roof surface, and any other obstruction within a horizontal distance of 18" (450mm).		

1 In accordance with the current CSA-B149 Installation Codes

2 In accordance with the current ANSI Z223.1/NFPA 54 National Fuel Gas Codes

† A vent shall not terminate directly above a sidewalk or paved driveway which is located between two single family dwellings and serves both dwellings

\* only permitted if veranda, porch, deck or balcony is fully open on a minimum 2 sides beneath the floor:

NOTE: 1. Local codes or regulations may require different clearances.

2. The special venting system used on Direct Vent appliances are certified as part of the appliance, with clearances tested and approved by the listing agency.

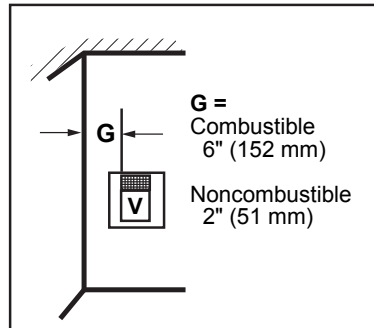
3. MHSC assumes no responsibility for the improper performance of the appliance when the venting system does not meet these requirements.

**Fig. 9** Vent termination clearances.  
30005123

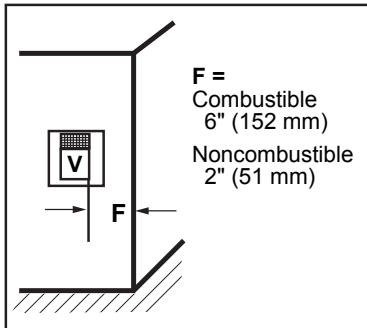
### Termination Clearances

Termination clearances for buildings with combustible and noncombustible exteriors.

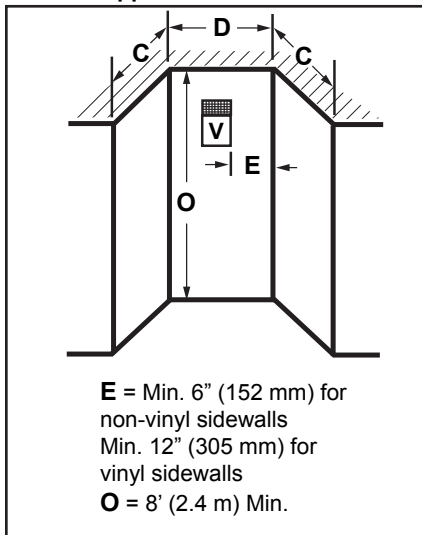
#### Inside Corner



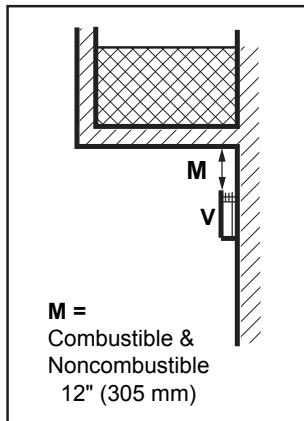
#### Outside Corner



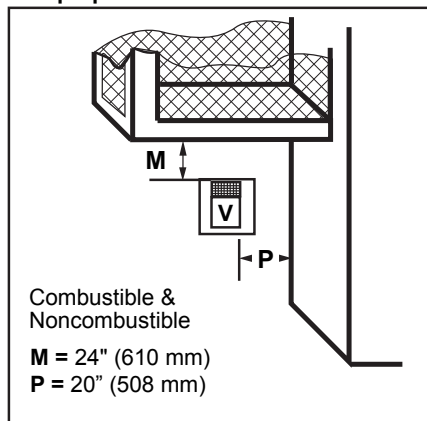
#### Alcove Applications\*



#### Balcony - with no side wall



#### Balcony - with perpendicular side wall



No. of Caps	D <sub>Min.</sub>	C <sub>Max.</sub>
1	3' (914 mm)	2 x D <sub>Actual</sub>
2	6' (1.8 m)	1 x D <sub>Actual</sub>
3	9' (2.7 m)	2/3 x D <sub>Actual</sub>
4	12' (3.7 m)	1/2 x D <sub>Actual</sub>

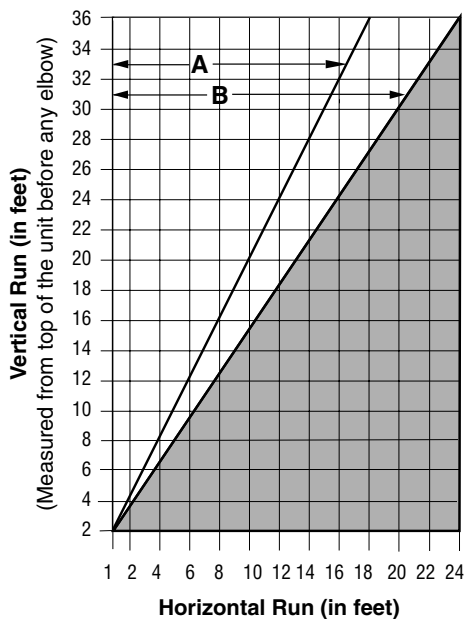
D<sub>Min.</sub> = # of Termination caps x 3  
 C<sub>Max.</sub> = (2 / # termination caps) x D<sub>Actual</sub>

584-15

**\*NOTE:** Termination in an alcove space (spaces open only on one side and with an overhang) is permitted with the dimensions specified for vinyl or non-vinyl siding and soffits. 1. There must be a 3' (914 mm) minimum between termination caps. 2. All mechanical air intakes within 10' (1 m) of a termination cap must be a minimum of 3' (914 mm) below the termination cap. 3. All gravity air intakes within 3' (914 mm) of a termination cap must be a minimum of 1' (305 mm) below the termination cap.

Fig. 10 Termination clearances.

### Venting Requirements - Natural Vent Only



#### Venting Runs

**NOTE:** When venting straight vertical, without any elbow, a minimum of 8 ft. vertical is required off the top of the stove.

- = Acceptable venting configuration
- = Unacceptable venting configuration

- A:** Vertical installations up to 36 feet (12m) in height. Up to an 18 ft. horizontal vent run can be installed within the vent system using a maximum of two 90-degree elbows or four 45-degree elbows.
- B:** Vertical installations up to 36 feet (12m) in height. Up to a 24 ft. horizontal vent run can be installed within the vent system using a maximum of two 45-degree elbows. (Ratio = 2/3, Hor./Vert.)

FP567b

Fig. 11 Vent termination window - Natural Vent ONLY.

**NOTE:** When using the FSDHAG, the restrictor plate supplied with the stove is not used.

**Venting Requirements and Options -  
Direct Vent ONLY**

**Approved Vent System Components**

The heater must be vented to the outdoors through an adjacent exterior wall or through the roof. The venting system must be comprised of the appropriate listed venting components specified on this page. These parts are available from DuraVent Corporation or your MHSC Dealer.

Refer to Figure 4 for dimensions relevant to the standard minimum-vent kits.

**Simpson DuraVent Components**

<b>Minimum Horizontal Vent Kit</b>	<b>2792</b>
Starter Pipe Assembly (incl. inner & outer sections)	2768*
90° Elbow, Blk.	990B*
45° Elbow, Gal.	945
6" Straight, Blk.	908B*
9" Straight, Blk.	907B
11" - 14B\," Adjustable Straight Section	911B
12" Straight	906
24" Straight	904B*
36" Straight	903B
48" Straight	902
Horizontal Vent Cap	984*
Wall Plate	940*
Vinyl Siding Shield	950
Snorkel Termination - 14"	982
Snorkel Termination - 36"	981
Wall Strap	988
Cathedral Ceiling Support Box	941
Storm Collar	953
Firestop Spacer	963
Flashing 0/12 - 6/12	943
Flashing 6/12 - 12/12	943S
Steel Chimney	
Kit A	931
Kit B	932
Kit C	933
Masonry Chimney Kit	934
Vertical Termination Cap (High Wind)	991
Vertical Termination Cap (Low Profile)	980

\*Included in Minimum Horizontal Vent Kit #2792

All DuraVent Straight vent pipe sections have a net length 1½" (37mm) less than the nominal dimension; i.e., a 6" (152mm) Straight pipe section has an effective length of 4½" (115mm).

**MHSC Vent Components**

The following kits are available to meet the needs of most installations. All pipe has a 7" outer diameter and includes a 4" diameter inner section. A (CG) designation indicates the part is finished in Charcoal Gray paint. Consult your dealer about other vent parts that may be appropriate to complete the installation.

<b>Min. Through the Wall Vent Kit</b>	<b>7TFSSK</b>
(1) 90-Degree Elbow (CG)	
(1) 24" Straight pipe (CG)	
(1) 36" Straight pipe (CG)	
(1) Side Wall Termination	
(1) Firestop	
(1) Zero-clearance sleeve	
(1) Hardware package	

(1) Finishing plate (CG)	
(1) Finishing collar (CG)	
(4) Polished Brass flue pipe rings	
<b>Through the Wall Vent Kit</b>	<b>7TFSDVSK</b>
(1) 90-Degree Elbow (CG)	
(1) 24" Straight pipe (CG)	
(1) 48" Straight pipe (CG)	
(1) Side Wall Termination	
(1) Firestop	
(1) Zero-clearance sleeve	
(1) Hardware package	
(1) Finishing plate (CG)	
(1) Finishing collar (CG)	
(4) Polished Brass flue pipe rings	
<b>Through the Wall Vent Kit for Below-Grade Termination</b>	<b>7TFSDVSKS</b>
Includes all of the above parts plus	
(1) Snorkel Termination	
<b>Vertical Termination Kit, 1/12-6/12 Pitch</b>	<b>7TDVSKVA</b>
(1) Combination Horizontal Offset / Roof Support	
(1) Vertical Termination	
(1) Storm Collar	
(1) 1/12-6/12 Flashing	
(1) Finishing Plate (CG)	
(1) Finishing Collar (CG)	
(1) Polished Brass Flue Pipe Ring	
(1) Hardware Package	
<b>Vertical Termination Kit, 7/12-12/12 Pitch</b>	<b>7TDVSKVB</b>
(1) 7/12 - 12/12 Flashing	
and all of the other Vertical Termination parts.	
<b>Vertical Termination, Flat Roof</b>	<b>7DVSKVF</b>
(1) Flat Flashing	
and all of the other Vertical Termination parts.	
<b>Twist Lock 24" Straight Pipe (CG)</b>	<b>7TFSDVP24</b>
(1) 24" Non-adjustable Pipe	
(1) Polished Brass Flue Pipe Ring	
<b>Twist Lock 48" Straight Pipe (CG)</b>	<b>7TFSDVP48</b>
(1) 48" Nonadjustable Pipe	
(1) Polished Brass Flue Pipe Ring	
<b>Twist Lock 45-Degree Elbow (CG)</b>	<b>7TFSDVT45</b>
for vertical offsets	
(1) 45-degree Elbow	
(1) Polished Brass Flue Pipe Ring	
<b>Draft Hood Adapter</b>	<b>FSDHAG</b>
<b>NV Stove Kit</b>	<b>7FSSK</b>
(1) 7" Diameter Polished Brass Trim Ring	
(1) 48" Nonadjustable Pipe (CG)	
(1) 24" Nonadjustable Pipe (CG)	
(1) Finishing Plate	
(1) Finishing Collar (CG)	
(1) 90 Degree Elbow (CG)	
<b>Stove Kit</b>	<b>7FSDHASK</b>
Includes all parts in the 7FSSK plus the Draft Hood Adapter	
FSDHAG	
<b>Combination Offset/Roof Support</b>	<b>7DVCS</b>
<b>Attic Insulation Shield</b>	<b>7DVAIS</b>
<b>7" Charcoal Gray Pipe Rings, (4)</b>	<b>7FSDRG</b>
<b>7" Polished Brass Pipe Rings (4)</b>	<b>7FSDRP</b>
<b>Wall Thimble</b>	<b>942G</b>

**NOTE:** Direct vent pipe may be used on the Natural Vent system from the top of the draft hood adapter to the ceiling.

## Install the Optional Fan

If you are installing the optional convection Fan Kit #2767 (FK26), continue here. If you are not installing a Fan Kit, go to Page 15, Venting System Assembly.

1. The fan kit includes a Blower Assembly and a Rheostat Assembly, connected by a cable. (Fig. 12) The Blower Assembly mounts to the bottom rear of the stove, and the Rheostat mounts to the valve coverplate. The assembly includes a 'snapstat' which automatically turns the fan On (or Off) above (or below) approximately 109°. The Rheostat also provides a range of fan speed settings from Off (which overrides the snapstat function) to High. Unpack and inspect the Blower assembly. Confirm that the fan spins freely.

### WARNING

This appliance is equipped with a three-prong (grounded) plug for your protection against shock hazard and should be plugged directly into a properly grounded three-prong receptacle. Do not cut or remove the grounding prong from this plug.

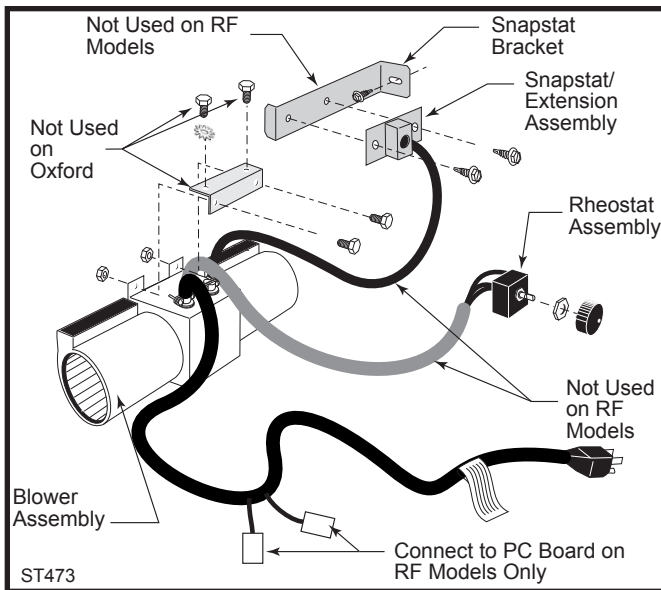


Fig. 12 Fan kit components.

2. Remove the rear skirt insert panel at the bottom of the Rear Skirt (Fig. 13) and fasten the blower assembly to the firebox back with the two Phillips pan-head bolts originally installed in the firebox back. ('1', Fig. 14)
3. Attach the snapstat assembly to the snapstat bracket with two sheet-metal screws. ('2', Fig. 14) Attach the snapstat bracket to the stove with a hex-head bolt passing through the bracket and into the stove base. ('3', Fig. 14)
4. The rheostat control switch attaches to the left side of the valve bracket at the front of the stove.

- Remove retaining nut from shaft of rheostat. (if preinstalled)
- Insert the rheostat through the hole in the back of the left side of the valve bracket, aligning the locator pin with the smaller hole in that bracket.
- Thread the retaining nut onto the shaft of the rheostat, tightening with a wrench. Do not over-tighten.
- Attach the control knob to the rheostat shaft.
- Use the wire tie to secure the fan and rheostat wire harnesses together.

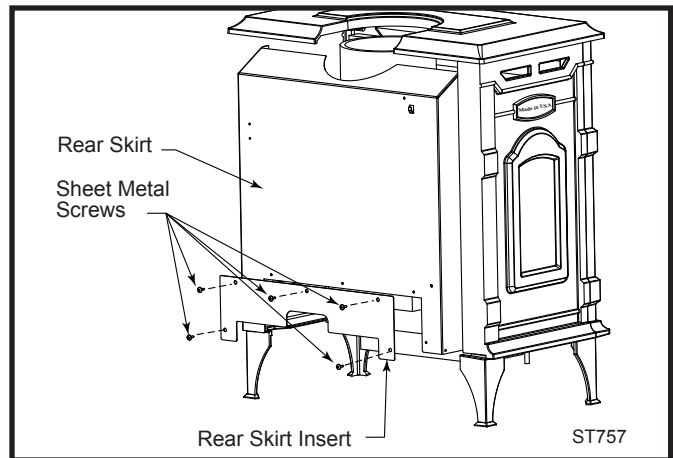


Fig. 13 Remove rear skirt insert.

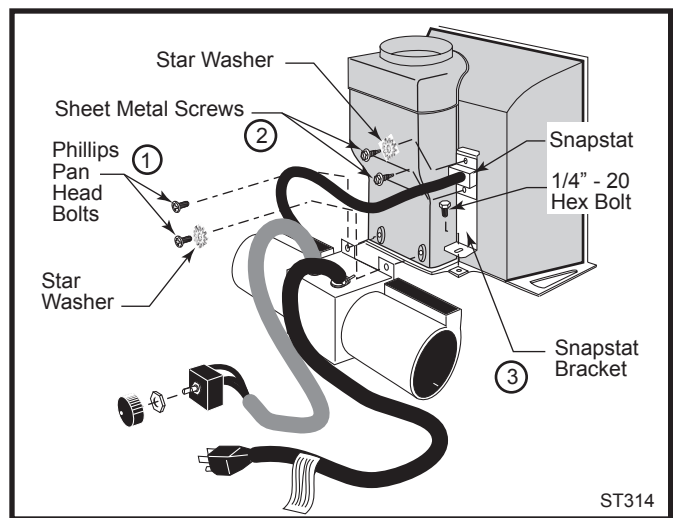


Fig. 14 Attach the fan assembly and the snapstat.

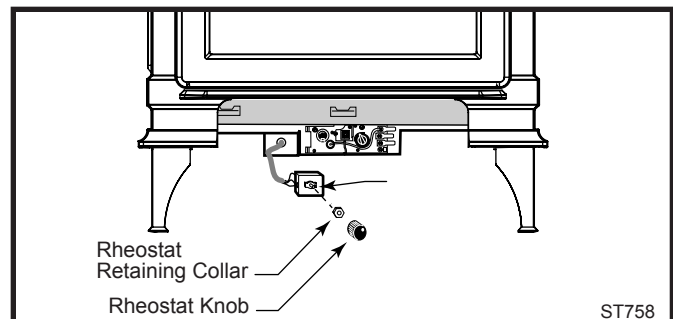


Fig. 15 Attach the fan rheostat.

## Venting System Assembly - Direct Vent General Information

The Oxford is approved for installation only with the vent components listed on Page 13. Follow the vent component instructions exactly.

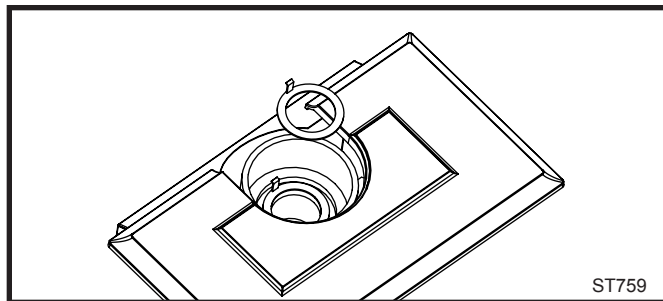
**For U.S. installations:** The venting system must conform with local codes and/or the current National Fuel Gas Code, ANSI Z223.1/NFPA 54.

**For Canadian installations:** The venting system must conform to the current CSA B149.1 installation code.

## Install the Vent Adapter Pipe

### (MHSC Vent Components)

- 1. Install the Restrictor Plate.** Consult the 'Vent Run Specifications' on Page 8 to determine whether the restrictor plate is needed. If so, put the restrictor plate in place within the inner flue collar as shown in Figure 16.



**Fig. 16** Install the restrictor plate only if required for the venting configuration. Refer to Page 9.

- 2. Attach Inner Starter Pipe,** (found in with the logset), to the next section of inner pipe.

- Run a bead of sealant about 1/2" from the upper end of the Inner starter pipe and join the two sections together.
- Drill three pilot holes into the Inner Starter and secure the assembly with three sheet metal screws. (Fig. 17)

- 3. Dry fit the Outer pipe assembly** to the stove for the purpose of determining the center line of the pipe on the wall.

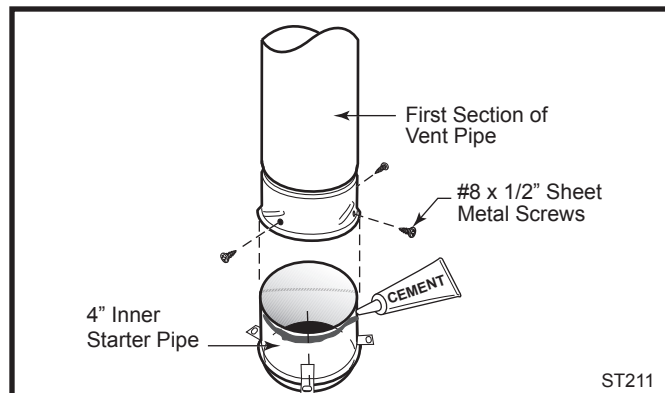
- **Side Wall Terminations:** Dry fit the outer elbow with the vertical outer vent and confirm the centerline alignment with the wall thimble opening.

Remove the pipes and elbows before continuing with Step 4.

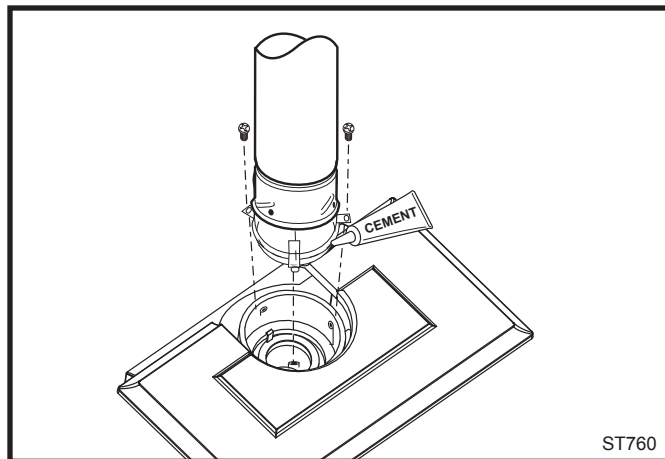
- 4. Attach the Inner Vent Assembly to the stove.**

- Run a bead of sealant around the bottom end of the starter pipe and attach the assembly to the stove using three 1/4-20 x 3/8" Phillips screws provided in the parts bag. (Fig. 18)

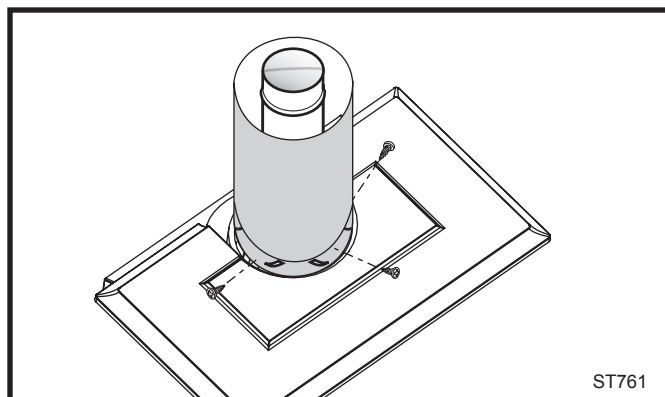
- 5. Install the Outer Adapter Pipe.** Apply a 1/4" bead of cement around the inside wall of the pipe, about 1" from the end. Insert the pipe over the stove flue collar, keeping the vertical seam oriented to the back of the stove. Also, be sure to align holes on the pipe with the holes on the flue collar of the firebox. Fasten the pipe to the holes in the flue collar with the #12 x 1/2" sheet metal screws provided. (Fig. 19)



**Fig. 17** Connect the inner starter with the next section of inner vent pipe.



**Fig. 18** Attach inner assembly to flue collar.



**Fig. 19** Fasten outer pipe with #12 x 1/2" sheet metal screw.

## Install the Vent Adapter Pipe

### (Simpson Dura-Vent Components)

- 1. Install the Restrictor Plate.** Consult Page 9 to determine whether the restrictor plate is needed. If so, place the restrictor plate into the inner flue collar. (Fig. 16)
- 2. Discard the inner starter pipe** shipped with the log-set. Using the starter pipe assembly listed on Page 7, slide the inner section out to allow access.
  - Run a bead of sealant around the bottom end of the starter pipe and attach the assembly to the stove using three 1/4-20 x 3/8" Phillips screws provided in the parts bag. (Fig. 20)
- 3. Install the Outer Adapter Pipe.** Apply a 1/4" bead of cement around the outside surface, about one inch from the crimped end. (Fig. 21) Orient the vertical seam to the rear, and insert the crimped end of the outer pipe into the flue collar. Fasten with three sheet metal screws provided.

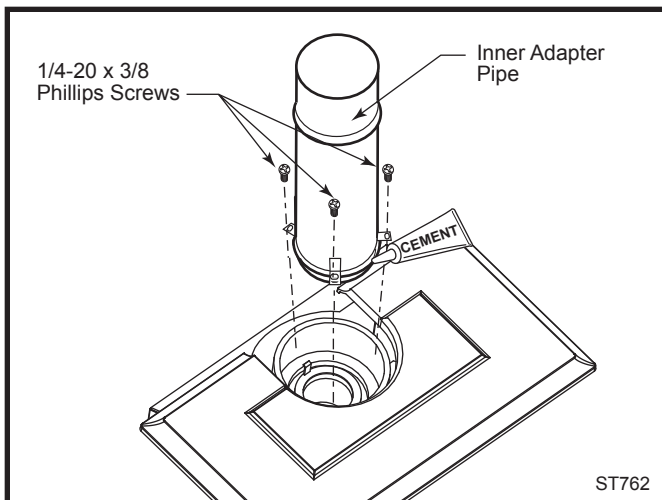


Fig. 20 Simpson DuraVent - install inner adapter pipe.

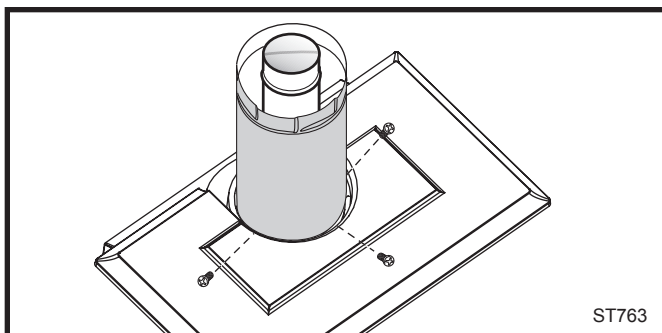


Fig. 21 Simpson DuraVent - install outer adapter pipe.

## Side Wall Termination Assembly

1. Locate the vent opening on the wall. Refer to Figure 5, Page 7, to determine the opening centerline. It may be necessary to first position the stove and measure to find the hole location. Depending on whether the wall is made of combustible materials, cut the opening to the size shown in Figure 22. Combustible wall openings must be framed as shown in Figure 22.

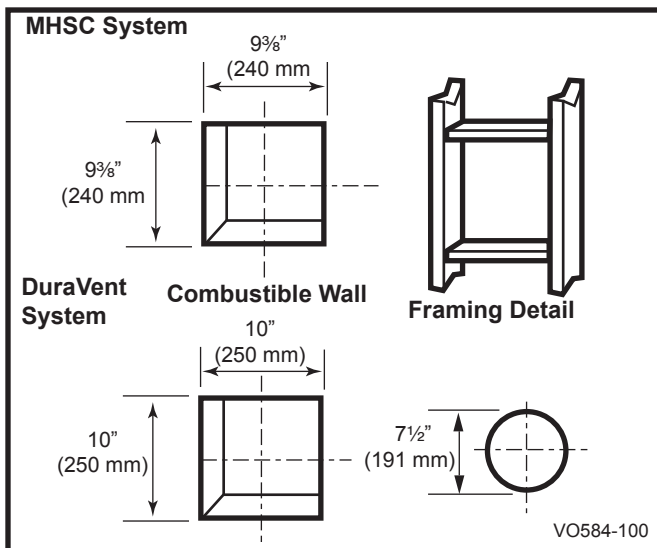


Fig. 22 Locate vent opening.

2. Measure the wall thickness and cut the wall sleeve sections to proper length (MAXIMUM 12"). Assemble the sleeve with the #8 sheet metal screws supplied. Attach the firestop plate to the sleeve end with the holes. (Fig. 23) **NOTE:** The wall sleeve is required in combustible walls only.
3. Install the Wall Firestop/Sleeve assembly into the wall cutout and fasten the firestop to the wall cutout framing members. (Fig. 23)

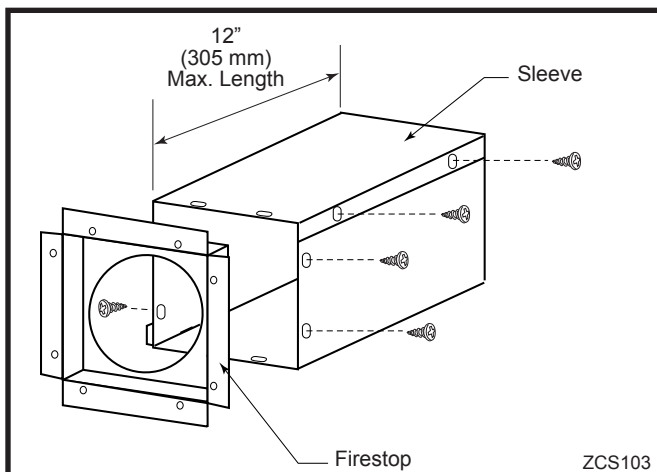


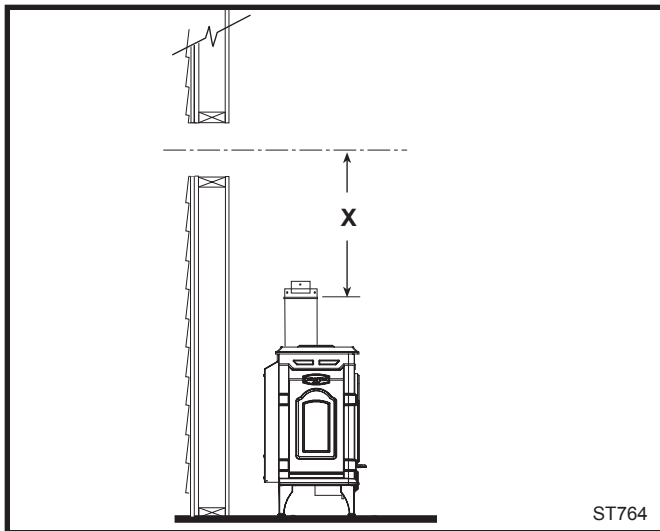
Fig. 23 Assemble the wall sleeve and firestop.



**For DuraVent pipe only:** Install vent pipe by aligning the locking system together, sliding the pipes together and twisting clockwise.

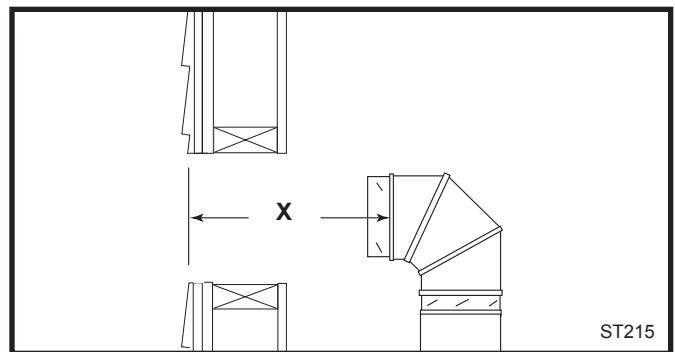
- Install 90° elbow. Twist lock as before.
- Slide the wall plate over horizontal run before attaching the horizontal run to the elbow. Fasten wall plate to wall.

**4. For MHSC Vent Pipe only:** If necessary, measure to determine the vertical length (X) of pipe required from the adapter pipe to the wall cutout centerline, including a 2" (51mm) overlap at the joint. (Fig. 24) use a hacksaw or tin snips to trim the pipe as needed.

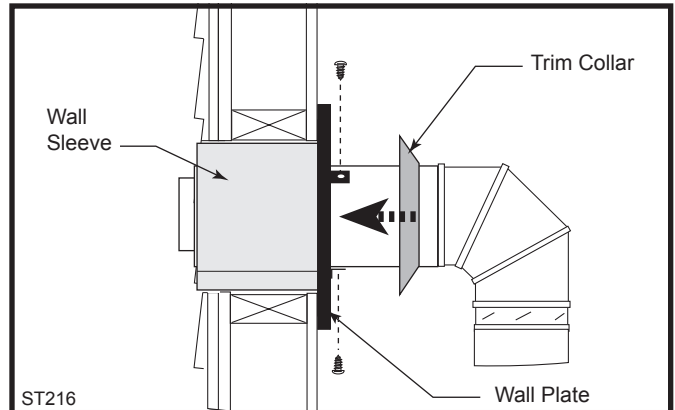


**Fig. 24** Determine the vertical pipe length.

5. Install first the inner then the outer straight pipe section(s), trimmed end down, to the point of the elbow. Drill 3 holes through each joint and fasten with sheet metal screws.
6. Seal and install the elbow using 3 sheet metal screws at each joint.
7. Measure, and cut if needed, the appropriate length of pipe section needed to make the connection through the wall. Include a 2" overlap; i.e. from the elbow to the outside wall face, about 2" or the distance required if installing a second 90° elbow. (Fig. 25)
8. Slip the wall plate and trim collar over the interior end of the horizontal pipe and install into the wall sleeve. Seal the joint inside the wall plate if needed to keep cold air from being drawn into the home.
9. Seal the ends and connect the horizontal pipe to the elbow. Fasten the wall plate to the pipe with three sheet metal screws. Slide the trim collar up against the wall plate to cover the screws. (Fig. 26)



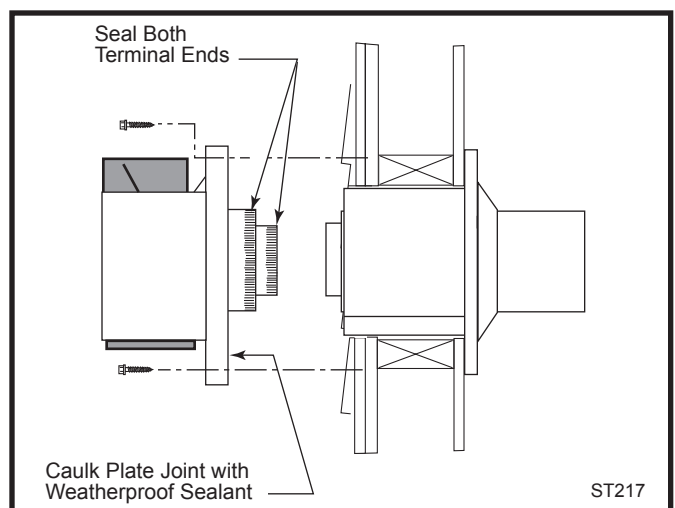
**Fig. 25** Measure the horizontal length.



**Fig. 26** Install the horizontal pipe and wall plate parts.

**10. For both MHSC and DuraVent Systems:** Install the vent terminal. (Fig. 27) Apply high temperature sealant one inch from the ends of the inner and outer collars. Guide the inner and outer vent termination collars into the adjacent pipes. Double check that the vent pipes overlap the collars by 2". Fasten the termination to the wall with the screws provided, and caulk the joint with weatherproof sealant.

**11. For MHSC only:** Install Charcoal Gray Pipe Rings (#7FSDRG) or Polished Brass Pipe Rings (#7FS-DRP) at pipe joints, if desired.



**Fig. 27** Install the vent terminal.

## Vent Termination Below Grade

Install Snorkel Kit #7FSDVSKS when it is not possible to meet the required vent termination clearances of 12" (305 mm) above grade level. The snorkel kit will allow installation depth of down to 7" (178 mm) below grade level. The seven inches is measured from the center of the horizontal vent pipe as it penetrates the wall. **If the venting system is installed below grade, a window well must be installed with adequate and proper drainage. (Fig. 28)**

**NOTE:** Be sure to maintain side wall clearances and vent run restrictions. Refer to Figures 3, 4, 7, and 8.

1. Establish the vent hole through the wall.
2. Remove soil to a depth of approximately 16" (406 mm) below the base of the snorkel. Install a window well (not supplied). Refill the hole with 12" (305 mm) of coarse gravel and maintain a clearance of at least 4" (102 mm) below the snorkel. (Fig. 28)
3. Install the vent system as described on Pages 15 - 17.
4. Be sure to make a watertight joint around the vent pipe joint at the inside and outside wall joints.
5. Apply high temperature sealant around the inner and outer snorkel collars. Join the pipes and fasten the snorkel termination to the wall with the screws provided.
6. Level the soil to maintain a 4" clearance below the snorkel.

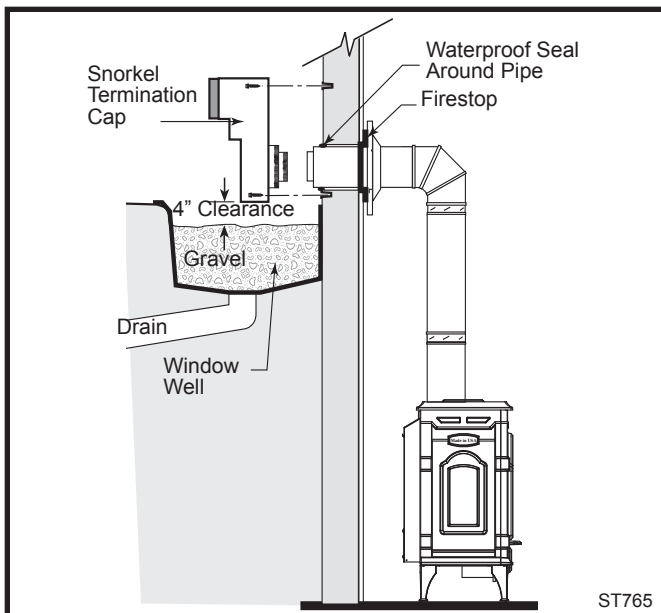


Fig. 28 Snorkel kit installation.

If the foundation is recessed, use extension brackets (not supplied) to fasten the lower portion of the snorkel. Fasten the brackets to the wall first, and then fasten to the snorkel with self-tapping #8 x 1/2" sheet metal screws. Extend the vent pipes out as far as the protruding wall face. (Fig. 29)

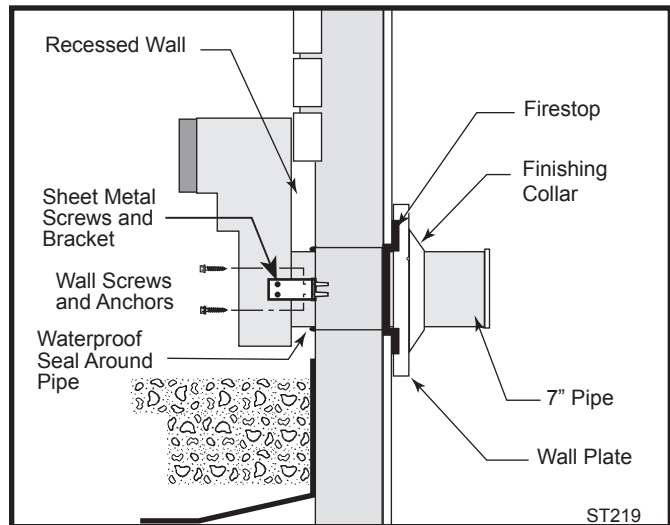


Fig. 29 Use extension brackets to mount snorkel against recessed wall.

## Vertical (Through the Roof) Vent Assembly

Note that all vertically terminated installations must include the restrictor plate included with the stove. Refer to Figure 8, Page 9.

Make certain the vent system conforms to all other requirements for vertical termination as specified on Page 9.

This installation will require you to first determine the roof pitch and use the appropriate vent components. Refer to Figures 8 and 9 on Pages 9 and 11.

1. Locate the final position of the stove, observing all clearances for both the vent and the stove.
2. Plumb to the center of the inner (4") flue collar from the ceiling above, and mark that location.
3. **Cut the opening:**  
**MHSC System: 9<sup>3</sup>/<sub>8</sub>" x 9<sup>3</sup>/<sub>8</sub>" (240 x 240mm)**  
**DuraVent System: 10" x 10" (254 x 254mm)**
4. Plumb any additional opening through the roof or other construction that may be needed. In all cases, the opening must provide a minimum of 1" (25 mm) clearance to the vent pipe.
5. Place the stove in its final position.
6. Install firestop(s) #7DVFS and Attic Insulation Shield #7DVAIS as needed. (Fig. 30) If there is a room above ceiling level, a firestop must be installed on both the bottom and top sides of the ceiling joists. If an attic is above ceiling level, an attic insulation shield must be installed.
7. Install the appropriate roof support and flashing, making certain that the upper flange of the flashing base is below the shingles. (Fig. 31)

8. Install appropriate pipe sections until the vent run reaches above the flashing. The enlarged ends of the vent sections always face downward.
9. Install the storm collar and seal around the joints. (Fig. 31)
10. Add additional vent lengths to achieve the proper overall height.
11. Apply cement to the inner and outer termination collars and install the terminal cap.

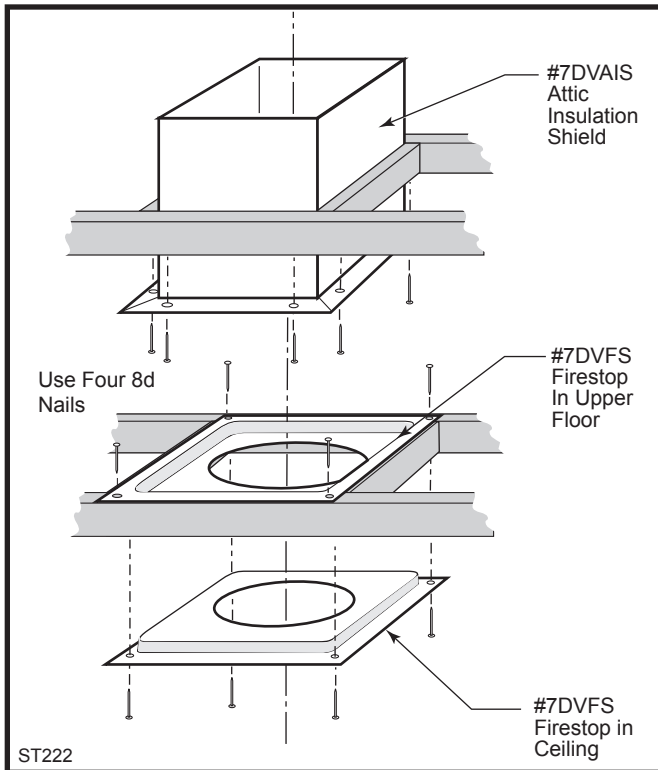


Fig. 30 Install firestops and attic insulation shield.

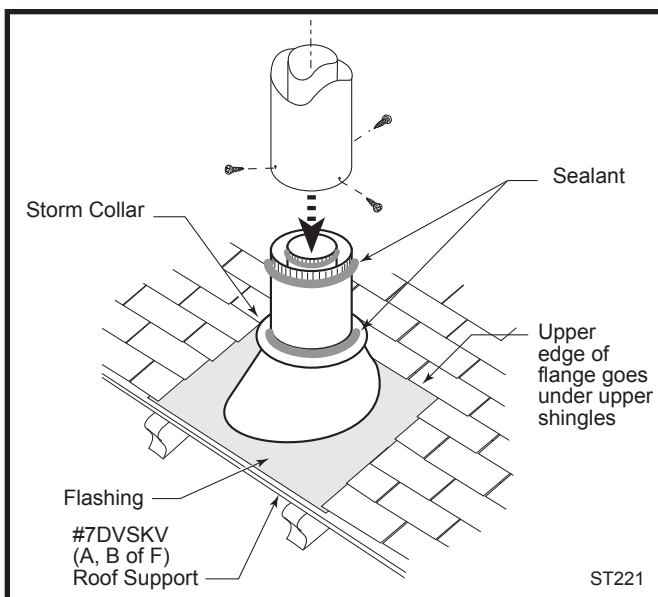


Fig. 31 Roof support and flashing.

## Venting System Assembly - Natural Vent General Information

The heater is shipped from the factory as a Direct Vent Heater. It may be converted to a Natural Vent heater by installing the Model FSDHAG Draft Hood Adapter.

The heater is approved for installation as a Natural Vent. MHSC Direct Vent pipe could be used directly after the Draft Hood Adapter up to the ceiling, then B-vent pipe must be used. Do not mix types of B-vent pipe; use components from one maker or the other. Follow the vent component maker's instructions exactly. The heater will also accept standard or enamelled 7" (150 mm) diameter pipe, around the Type B venting, for decorative purposes only. (Fig. 32)

**NOTE: The restrictor plate supplied with the stove is not used for Natural Vent applications.**

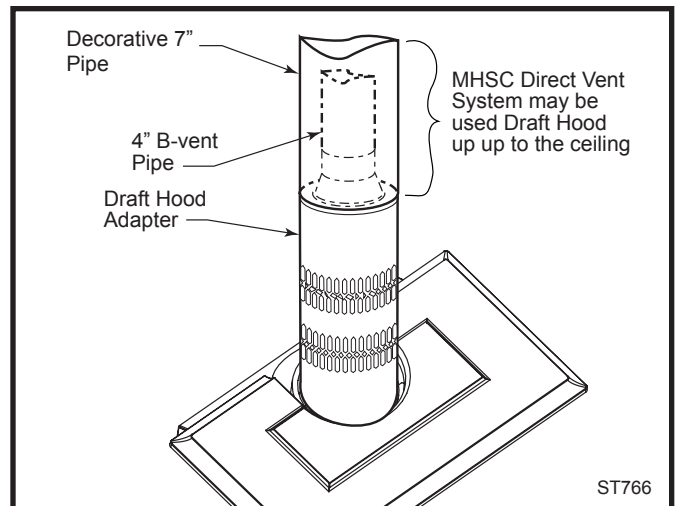


Fig. 32 Decorative 7" pipe may be fitted around the B-vent pipe.

The stove, when installed as a Natural vent heater, includes a vent safety switch. (Fig. 63, Page 32) Operating the stove when it is not connected to a properly installed and maintained venting system, or tampering with or disconnecting the vent safety switch, can result in carbon monoxide (CO) poisoning and possible death.

**For U.S. installations:** The venting system must conform with local codes and/or the current National Fuel Gas Code, ANSI Z22.1.

**For Canadian installations:** The venting system must conform to the current CSA B149.1 installation code.

## Install the Vent Pipe

Apply a bead of sealant around bottom end of inner starter pipe (found in bag with logset) and attach to stove. Apply a bead of sealant around top of inner starter pipe and install the FSDHAG Draft Hood according to Draft Hood instructions. (Fig. 33)

Attach the first section of venting to the draft hood. Depending on the length of the individual venting sections and the lengths of the decorative pipe (if installed), you may need to slip the decorative pipe over the venting sections before attaching upper sections to lower ones. The sections of decorative pipe should be oriented with their seams (if any) toward the wall; sections usually do not need to be fastened at each joint, other than slip sections. If the layout includes a slip section, this should be the last section of pipe visible in the room, at the ceiling. Complete the venting according to the vent maker's instructions.

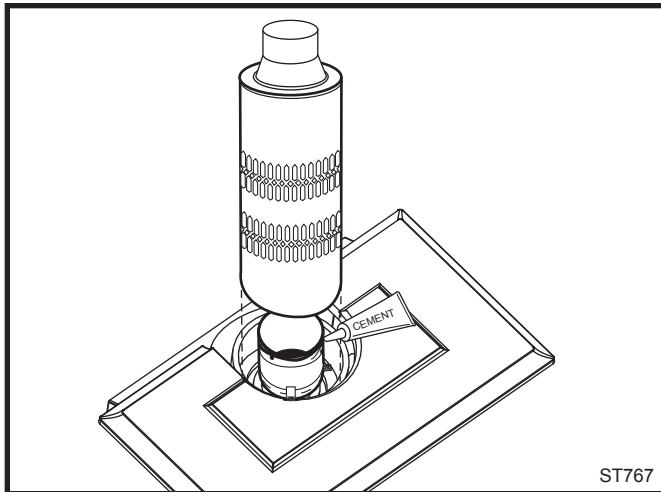


Fig. 33 Install draft hood adapter.

### Install the Log Set

1. Remove the logs from their packaging, and inspect each piece for damage. **DO NOT INSTALL DAMAGED LOGS.**
2. Install the rear log centering it side to side on the sheet metal shelf at the back of the firebox. (Fig. 34) The log will touch both sides and the back wall of the firebox.
3. Install the right log by engaging hole on bottom with pin on the rear log. (Fig. 34) Then set right bottom side on the burner so the edge of the log touches the right side of the firebox. The right log does not use the locator pins on the burner to stay in place.
4. Install the left log by engaging hole on bottom with pin on rear log. (Fig. 34) Then set left bottom side on the burner so the edge of the log touches the left side of the firebox.
5. Loosely sprinkle the lava rocks directly on top of the burner in front of and between the decorative grate and the right and left logs. Use the lava rock to cover brackets on the burner. (Fig. 35)

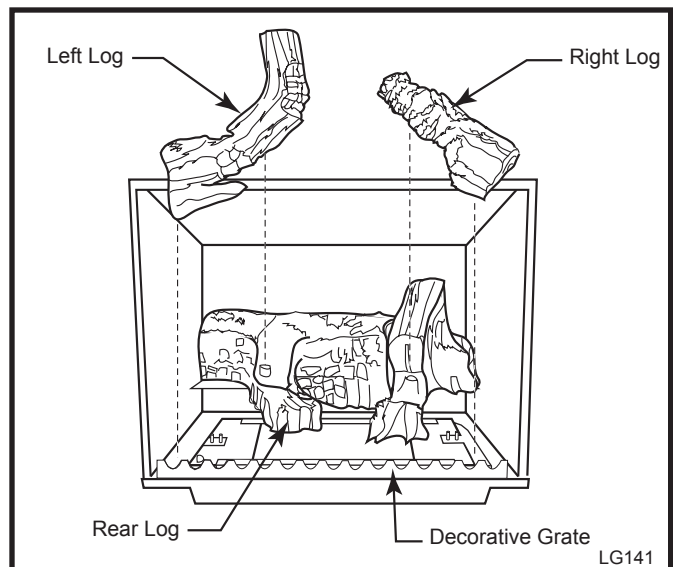


Fig. 34 Install the back, left and right logs.

### Connect the Gas Supply Line

Check the Rating Plate attached by a steel cable to the firebox, to confirm that you have the appropriate firebox for the type of fuel to be used. The Oxford may be converted from one gas to another using the appropriate Fuel Conversion Kit listed on Page 34.

### CAUTION



This appliance should only be connected by a qualified gas technician. Test to confirm manifold pressures as specified below.

The heater and its individual shutoff valve must be disconnected from the gas supply piping during any pressure testing of that system at test pressures in excess of 1/2 psig (3.5 kPa).

The heater must be isolated from the gas supply piping system by closing its individual manual shutoff valve during any pressure testing of the gas supply piping system at test pressure equal to or less than 1/2 psig.

There must be a gas shutoff between the stove and the supply.

In order to connect Natural Gas, use a fitting with 3/8" NPT nipple on the valve side and 1/2" natural gas supply line with an input of 28,000 BTUs at a manifold pressure of 3.5" and minimum inlet supply for adjustment of 5.5" w.c.

In order to connect Propane, use a fitting with 3/8" NPT nipple on the valve side and 1/2" propane gas supply line with an input of 28,000 BTUs at a manifold pressure of 10.0" and minimum inlet supply for adjustment of 11.0" w.c.

**In the U.S.;** Gas connection should be made in accordance with current National Fuel Gas Code, ANSI Z223.1/NFPA 54. Since some municipalities have additional local codes, be sure to consult your local authority.

**In Canada;** consult the local authority and CSA-B149.1 installation code.



**Always check for gas leaks with a mild soap and water solution. Do not use an open flame for leak testing.**

Light the pilot according to the directions on Page 25, before going to the next step.

### Burner Information

The appliance must only use the gas specified on the rating plate, unless converted using a Fuel Conversion Kit. To convert from LP to Natural Gas use Kit #30005155. To convert from Natural Gas to LP use Kit #30005154.

Conversion instructions are provided with each kit and beginning on Page 27 in this manual.

**This appliance should be connected to the gas supply only by a qualified gas service technician. Follow all local codes.**

**There must be a gas shut-off between the stove and the supply.**

**In order to connect Natural Gas,** use a fitting with 3/8" NPT nipple on the valve side and 1/2" natural gas supply line with an input of 28,000 BTUs at a manifold pressure of 3.5" and minimum inlet supply for adjustment of 5.5" w.c.

**In order to connect Propane,** use a fitting with 3/8" NPT nipple on the valve side and 1/2" propane gas supply line with an input of 28,000 BTUs at a manifold pressure of 10.0" and minimum inlet supply for adjustment of 11.0" w.c.

### Air Shutter Adjustment

The Oxford is shipped from the factory with the air shutter adjusted to the minimum allowed opening. Refer to Table 1. Based on the altitude where the stove is located, a shutter adjustment is acceptable to provide a mixed balance of flame color/glow. To adjust the shutter opening, follow the steps below.

**NOTE:** The air shutter may only be adjusted to a more open position. The factory setting is the minimum allowable air shutter opening. (Figs. 38 & 39)

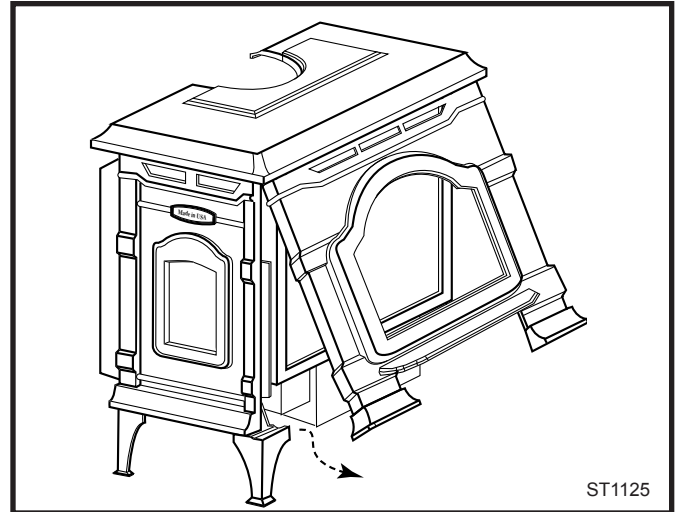
**Table 1. Air Shutter Adjustment**  
Minimum rear injector inlet openings.

Model	Natural Gas	LP
Direct Vent	1/2"	1/2"
Natural Vent	1/2"	1"

### Air Shutter Adjustment Instructions

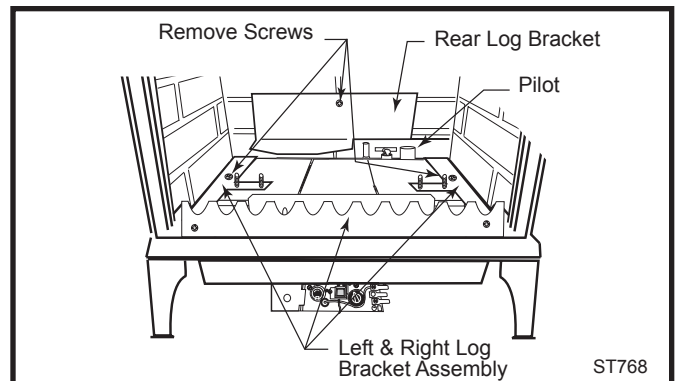
To adjust the air shutter, the following procedures should be followed:

1. Remove stove front. Lift stove front up and then swing bottom out and away to disengage from the stove body. (Fig. 36)
2. Swing open the swiveling latches at the top left and right corners of the glass frame. (Fig. 59, Page 31)



**Fig. 36** Remove stove front.

3. Pull the top edge of the glass and frame assembly away from the firebox, and lift it off its supports on the bottom of the firebox face. Place the assembly out of the way on a flat, padded surface such as a counter protected by a towel.
4. Take the logset out of the firebox if previously installed.
5. Remove the rear log bracket by unfastening the screw. (Fig. 37)
6. Remove the right and left log bracket assembly by unfastening the two screws which hold the burner in place. (Fig. 37)
7. Hold the burner at the right hand side and lift to clear the right burner leg. Then pull to the right to clear the injectors on the left hand side.



**Fig. 37** Remove rear log bracket and left and right log bracket assembly.

8. The air shutter is located on the bottom of the burner to the left. (Fig. 37) Unfasten the two nuts holding the shutter in place. The shutter may be adjusted between the factory adjusted 1/2" to fully open. Reassemble the shutter to allow the rear injector air inlet to close from the minimum 1/2" opening to fully open. (Fig. 39) You may have to try more than once to find the correct air shutter opening for best results depending on your altitude.

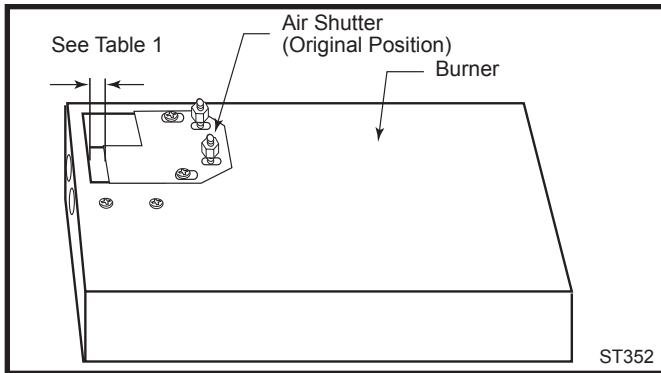


Fig. 38 Air shutter in original from-the-factory position.

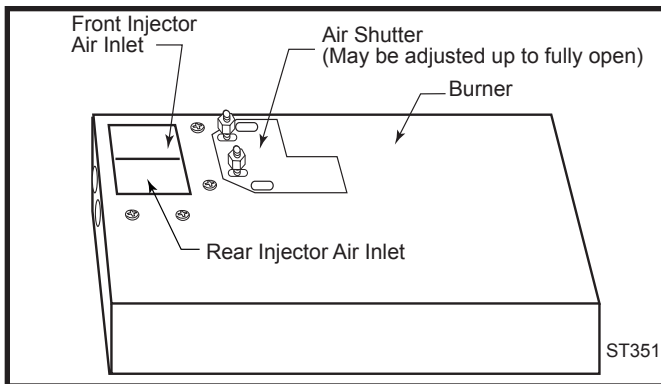


Fig. 39 Air shutter adjusted.

9. Refasten the two nuts and assemble the burner into the unit by sliding the burner in at an angle with the left side lower than the right side. Slide the left side onto the injectors. Lower the right hand side down into place. Make sure the burner is as far left as possible and the injector shoulders are inside the burner. **NOTE:** It is very critical to keep the left burner leg, which holds the injectors, at a 90° angle to the base. (Fig. 40) This keeps the orifices aligned with tubes on the inside of the burner. Failure to do so could affect the flame appearance and performance of the unit.

10. Refasten the right and left log bracket assembly.

11. Refasten the rear log bracket.

12. Replace logs.

13. Replace glass and stove front.

Follow lighting instructions on Page 25. Check flame color appearance. **NOTE:** Allow stove to burn for at least 1/2 hour to establish full flame color.

Should color need further adjustment, repeat steps 1 - 12 for air shutter adjustment.

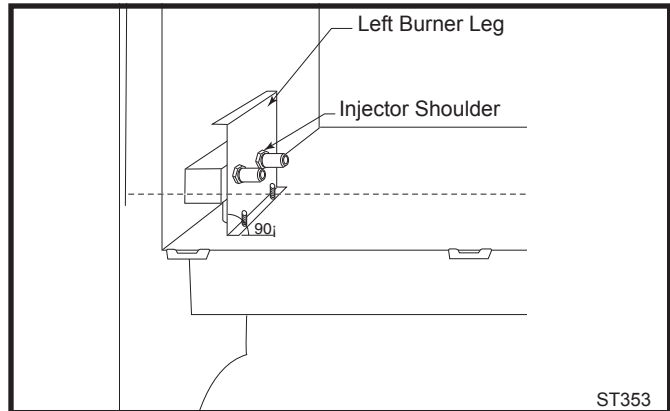


Fig. 40 Be sure to maintain 90° angle at left burner leg.

### Complete the Assembly

- Open the swiveling latches (cams) on the top left and right corners of the glass frame.
- Position the glass and frame against the firebox by placing the bottom edge on the brackets on the bottom face of the firebox.
- Swing the assembly against the firebox, and close the latches firmly against the pins protruding from the firebox top.

### Install ON/OFF Switch

The switch assembly parts are found in the parts bag.

1. Attach switch assembly to left rear side of stove shroud (when facing shroud) using two screws and existing holes in shroud. (Fig. 41)
2. Run wires down back of stove, under bottom of rear shroud to valve.
3. Attach wires to valve terminals. (Fig. 42)

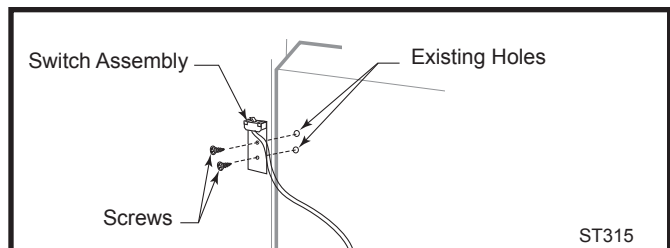


Fig. 41 Attach switch assembly to rear shroud.

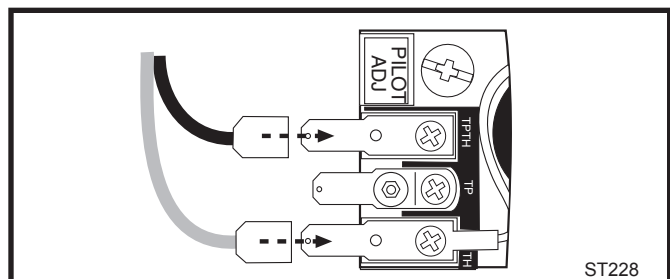


Fig. 42 Attach switch wires to valve.

### Thermostat Connection (optional)

Use only a thermostat rated for 500 millivolts. Check the table below for the appropriate gauge thermostat wire to use for the length of lead required in your installation.

Thermostat Wire / Gauge	Maximum Run
18	20 feet
16	20 - 40 feet
14	up to 60 feet

1. Install the wall thermostat in the desired location and run the wires to the stove location. Terminate these leads with 1/4" female connectors.
2. Connect the thermostat wires to the valve. (Fig. 42)

### Install the Stove Front

Insert the handle stub into the hole in the front casting. Fasten in place with the 3/8" locking nut provided. (Fig. 43)

The front attaches to the stove by four steel tabs that engage with corresponding cast ribs onto the sides and bottom of the stove body. Position the front about 3" down from stove top and lift the plate to engage the upper tabs behind the adjacent ribs on the sides. (Fig. 44) Then lower the front into position, so the lower tabs engage with the corresponding ribs at the bottom.

When properly installed, the bottom of the stove front cannot be pulled away from the sides without also lifting it.

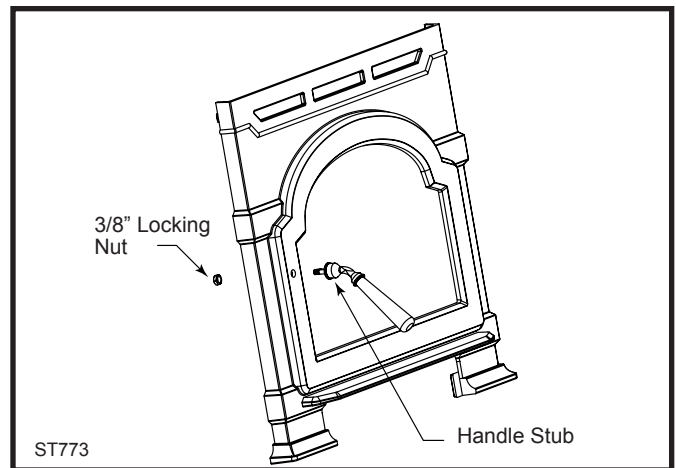


Fig. 43 Insert handle stub into hole in front. Secure with 3/8" locking nut.

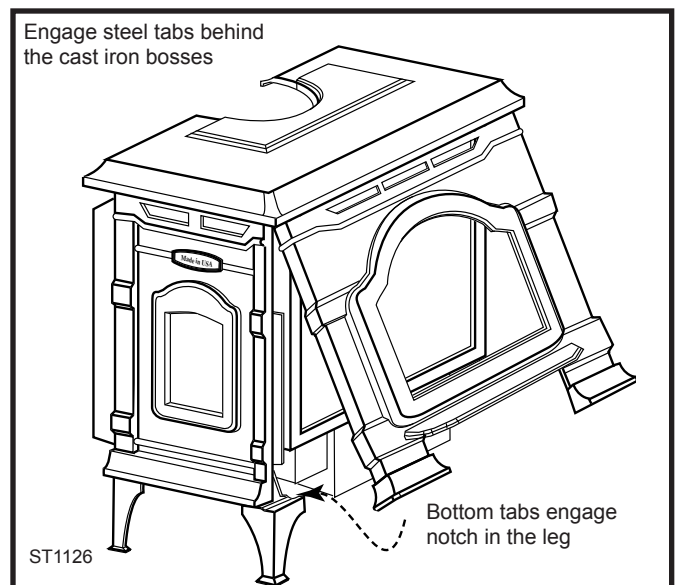


Fig. 44 Install the front plate.

# Operation

## Your First Fire

Read these instructions carefully and familiarize yourself with the burner controls. Locate the pilot assembly, Figure 45. Follow the lighting instructions on Page 25 exactly.

During the first fire, it is not unusual to smell some odor associated with new logs, paint and metal being heated. Odors should dissipate within an hour or so, however, you can open a window to provide fresh air to alleviate the condition.

## Pilot and Burner Inspection

Each time you light your heater check that the pilot flame and burner flame patterns are as shown in Figure 47. If flame patterns are incorrect, turn the heater off. Contact your dealer or a qualified gas technician for assistance. Do not operate the heater until the pilot flame is correct.

Follow regular maintenance procedures as described on Page 30.

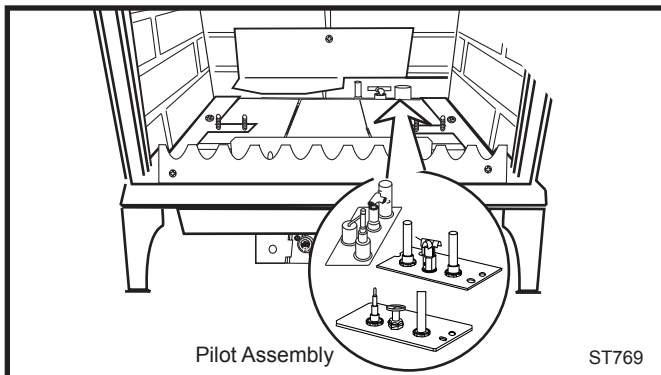


Fig. 45 Pilot assembly location.

## Flame & Temperature Adjustment

For stoves equipped with HI/LO valves, flame adjustment is accomplished by rotating the HI/LO adjustment knob located near the center of the gas control valve. (Fig. 46)

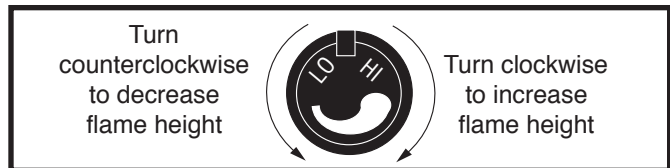


Fig. 46 Flame adjustment knob for Honeywell valve.

## Flame Characteristics

It is important to periodically perform a visual check of the pilot and the burner flames. Compare them to Figure 47. If any of the flames appear abnormal, call a service person.

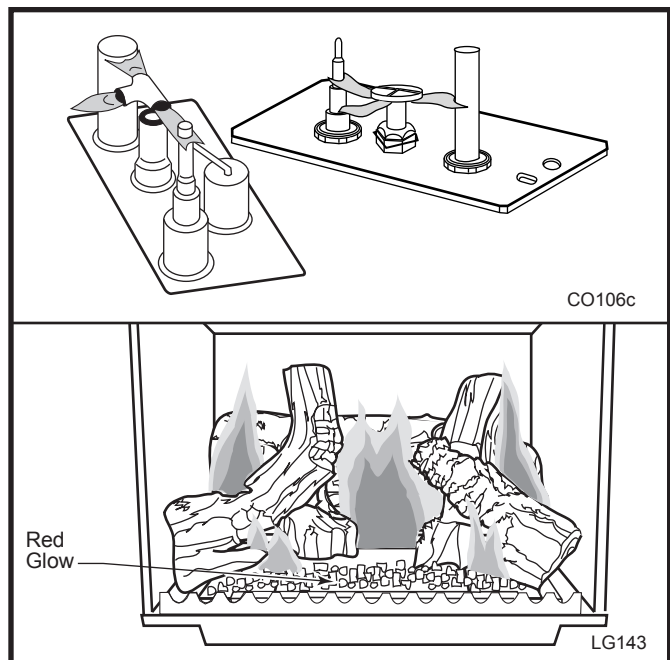


Fig. 47 Correct pilot and burner flame patterns.



# Lighting and Operating Instructions

## FOR YOUR SAFETY READ BEFORE LIGHTING

**WARNING:** If you do not follow these instructions exactly, a fire or explosion may result causing property damage, personal injury or loss of life.

- A. This heater has a pilot which must be lit manually. When lighting the pilot follow these instructions exactly.
- B. BEFORE LIGHTING smell all around the heater area for gas. Be sure to smell next to the floor because some gas is heavier than air and will settle on the floor.


### WHAT TO DO IF YOU SMELL GAS

- Do not try to light any fireplace
- Do not touch any electric switch
- Do not use any phone in your building
- Immediately call your gas supplier from a neighbor's phone.

### Follow the gas supplier's instructions.


- If you cannot reach your gas supplier, call the Fire Department
- C. Use only your hand to push in or turn the gas control knob. Never use tools. If the knob will not push in or turn by hand, do not try to repair it, call a qualified service technician. Applying force or any attempted repair may result in a fire or explosion.
- D. Do not use this fireplace if any part has been under water. Immediately call a qualified service technician to inspect the heater and to replace any part of the control system and any gas control which has been under water.

## Lighting Instructions

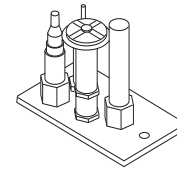
1. **STOP!** Read the safety information above.
2. Turn off all electrical power to the fireplace.
3. Turn the ON/OFF switch to "OFF" position, set the remote to OFF or set thermostat to lowest level.
4. Open control access panel.
5. Push in gas control knob slightly and turn clockwise  to "OFF".



SIT NOVA


6. Remove glass door before lighting pilot. (See Glass Frame Removal section).
7. Wait five (5) minutes to clear out any gas. Then smell for gas, including near the floor. If you smell gas, STOP! Follow "B" in the safety information above. If you do not smell gas, go to the next step.
8. Visibly locate pilot by the main burner.
9. Turn knob on gas control counterclockwise  to "PILOT".

10. Push the control knob all the way in and hold. Immediately light the pilot by repeatedly depressing the piezo spark ignitor until a flame appears. Continue to hold the control knob in for about one (1) minute after the pilot is lit. Release knob and it will pop back up. Pilot should remain lit. If it goes out, repeat steps 5 through 8.



- If knob does not pop up when released, stop and immediately call your service technician or gas supplier.
  - If after several tries, the pilot will not stay lit, turn the gas control knob to "OFF" and call your service technician or gas supplier.
11. Replace glass door.
  12. Turn gas control knob to "ON" position.
  13. Turn the ON/OFF switch to "ON" position or set thermostat to desired setting.
  14. Turn on all electrical power to the fireplace.

## To Turn Off Gas To Heater

1. Turn the ON/OFF switch to Off position or set the thermostat to lowest setting.
2. Turn off all electric power to the fireplace if service is to be performed.
3. Open control access panel.
4. Push in gas control knob slightly and turn clockwise  to "OFF". Do not force.
5. Close control access panel.

## Troubleshooting the Gas Control System

### SIT NOVA 820 MILLIVOLT VALVE

**NOTE:** Before trouble shooting the gas control system, be sure external gas shut off is in the "On" position.

Symptom	Possible Causes	Corrective Action
1. Spark ignitor will not light	A. Defective or misaligned electrode at pilot	Using a match, light pilot. If pilot lights, turn off pilot and push the red button again. If pilot will not light - check gap at electrode and pilot-should be 1/8" to have a strong spark.
	B. Defective ignitor (Push Button)	With the control knob in the pilot position, push the control knob all the way and hold. Check for spark at electrode and pilot. If no spark to pilot, and electrode wire is properly connected, replace the battery in the ignitor module and try again. Refer to Maintenance Section. If the problem still exists, replace the ignitor module box.
2. Pilot will not stay lit after carefully following lighting instructions	A. Defective pilot generator (thermocouple), remote wall switch	Check pilot flame. Must impinge on thermocouple/thermopile. NOTE: This pilot burner assembly utilizes both a thermocouple and a thermopile. The thermocouple operates the main valve operation (On and Off). Clean and or adjust pilot for maximum flame impingement on thermopile and thermocouple.
	B. Defective automatic valve	Turn valve knob to "Pilot". Maintain flow to pilot; millivolt meter should read greater than 10mV. If the reading is okay and the pilot does not stay on, replace the gas valve. NOTE: An interrupter block (not supplied) must be used to conduct this test.
3. Pilot burning, no gas to main burner	A. Wall switch or wires defective	Check wall switch and wires for proper connections. Jumper wire across terminals at wall switch, if burner comes on, replace defective wall switch.. If okay, jumper wires across wall switch wires at valve, if burner comes on, wires are faulty or connections are bad.
	B. Thermopile may not be generating sufficient millivoltage	<ol style="list-style-type: none"> <li>1. Be sure wire connections form thermopile at gas valve terminals are tight and thermopile is fully inserted into pilot bracket.</li> <li>2. One of the wall switch wires may be grounded. Remove wall switch wires form valve terminals if pilot now stays lit, trace wall switch wiring for ground. May be grounded to fireplace or gas supply.</li> <li>3. Check thermopile with millivolt meter. Take reading at thermopile terminals of gas valve. Should read 250-300 millivolts (minimum 150) while holding valve knob depressed in pilot position and wall switch "Off". Replace faulty thermopile if reading is below specified minimum.</li> </ol>
	C. Plugged burner orifice	Check burner orifices for debris and remove.
	D. Defective automatic valve operator	Turn valve knob to "On", place wall switch to "On" millivolt meter should read greater than 150mV. If the reading is okay and the burner does not come on, replace the gas valve.
4. Frequent pilot outage problem	A. Pilot flame may be too low or blowing (high) causing the pilot safety to drop out	Clean and/or adjust pilot flame for maximum flame impingement on thermopile and thermocouple.
	B. Possible blockage of the vent terminal	Check the vent terminal for blockage (recycling the flue gases).

## Fuel Conversion Instructions

**WARNING!** This conversion kit shall be installed by a qualified service agency in accordance with the manufacturer's instructions and all applicable codes and requirements of the authority having jurisdiction. If the information in these instructions is not followed exactly, a fire, explosion or production of carbon monoxide may result causing property damage, personal injury or loss of life. The qualified service agency is responsible for the proper installation of this kit. The installation is not proper and complete until the operation of the converted appliance is checked as specified in the manufacturer's instructions supplied with the kit.

**CAUTION:** The gas supply shall be shut off prior to disconnecting the electrical power, before proceeding with the conversion.

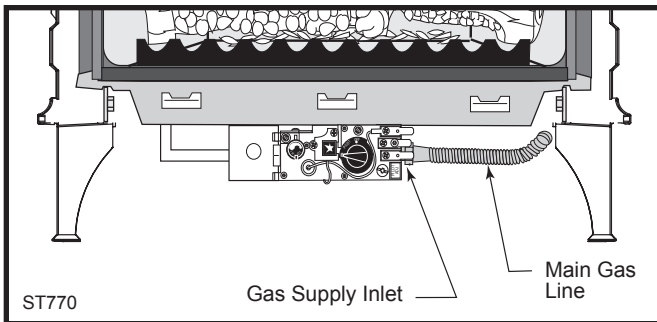


Fig. 48 Attach the gas line to the left side of the valve.

### Conversion Precautions

Before proceeding, turn control knob on valve to OFF and turn gas supply OFF. Turn OFF any electricity that may be going to the appliance.

### Conversion Procedure

1. Remove stove front. Lift stove front up and then swing bottom out and away to disengage from the stove body. (Fig. 58, Page 30)
2. Swing open the swiveling latches at the top left and right corners of the glass frame. (Fig. 59, Page 31)
3. Pull the top edge of the glass and frame assembly away from the firebox face. Place the assembly out of the way on a flat, padded surface such as a counter protected by a towel.
4. Remove the logset from the firebox.
5. Remove the rear log bracket by unfastening the screw. (Fig. 49)
6. Remove the right and left log bracket assembly by unfastening the two screws which hold the burner in place. (Fig. 49)

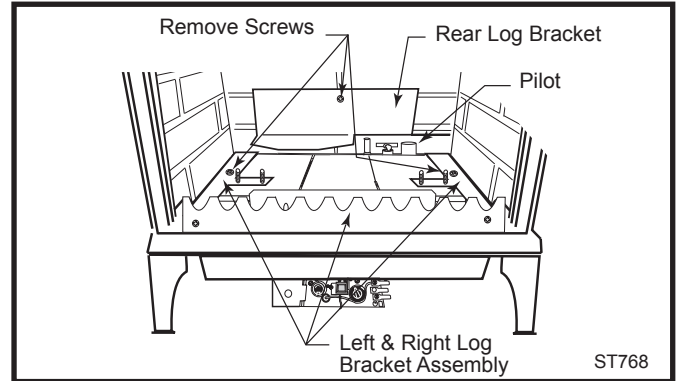


Fig. 49 Remove rear log bracket and left and right log bracket assembly.

7. Hold the burner at the right hand side and lift to clear the right burner leg. Then pull to the right to clear the injectors on the left hand side.
8. Remove injector orifices from left burner leg using 1/2" wrench. (Fig. 54)
9. Install conversion orifices. (Refer to Table 2)

### SIT 820 Valve

1. Using TORX T20 bit, remove and discard the three (3) pressure regulator mounting screws (A), pressure regulator tower (B) and the spring and diaphragm assembly (C). (Fig. 50)
2. Insure the rubber gasket (D) is properly positioned and install the new HI/LO pressure regulator assembly to the valve using the new screws (E) supplied with the kit. Tighten the screws securely. (Ref. torque = 25 in/lb) (Fig. 51)
3. Install the enclosed conversion label (F) to the valve body where it can easily be seen. (Fig. 51)

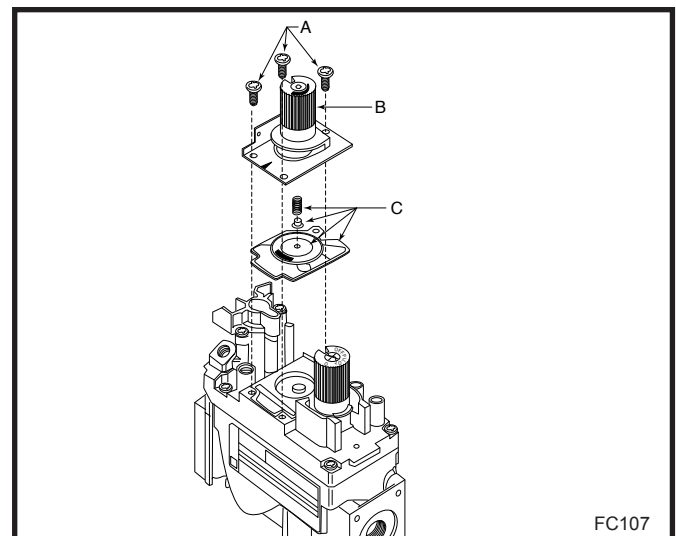


Fig. 50 Remove mounting screws, pressure regulator tower and spring and diaphragm assembly.

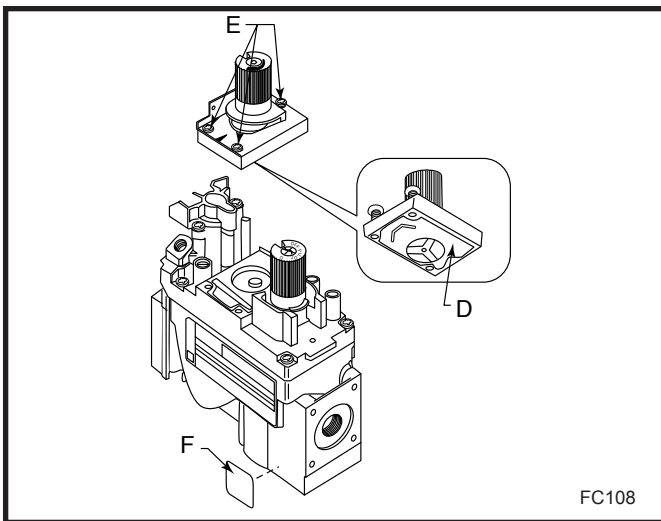


Fig. 51 Replace regulator.

**Pilot Orifice Conversion**

1. Locate pilot. (Fig. 49)
2. Replace pilot orifice.

**Pilot Type 1**

- Remove pilot hood by lifting up. (Fig. 52) Do not remove snap ring to remove pilot hood. **NOTE:** It is not necessary to remove the pilot tube for conversion.
- Remove pilot orifice with allen wrench. (Fig. 53)
- Install the conversion orifice.
- Reinstall pilot hood. Be sure to align hood with index tab.

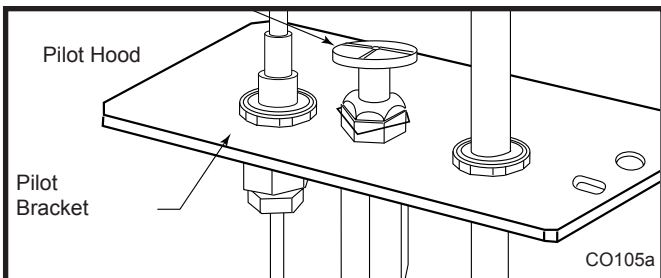


Fig. 52 Remove pilot hood.

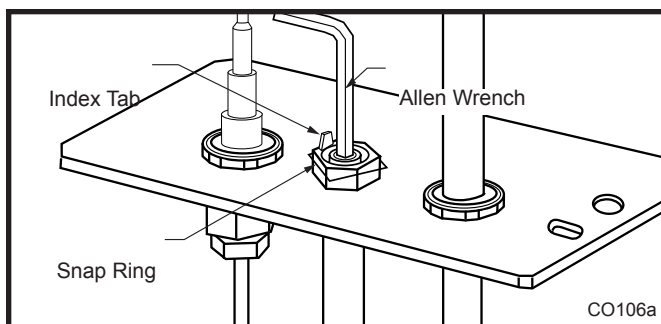


Fig. 53 Remove pilot orifice.

**Pilot type 2**

- Loosen pilot hood turning counterclockwise using a 7/16" wrench. (Fig. 54) **NOTE:** You may use penetrating oil to prevent pilot hood threads from seizing up.
- Remove pilot orifice with needlenose pliers. (Fig. 55) **NOTE:** Use a wrench to hold pilot tube in place while removing the orifice.
- Install the conversion orifice.
- Reinstall pilot hood and tighten until mark on pilot hood aligns with mark on pilot bracket.

**NOTE:** Be sure burner leg remains at a 90° angle to firebox base after conversion.

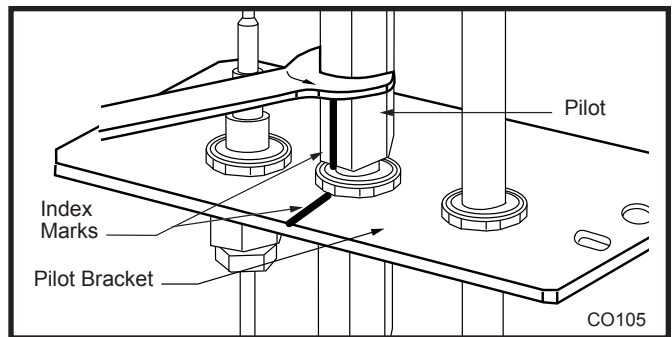


Fig. 54 Remove pilot hood. (Your pilot may have a different appearance).

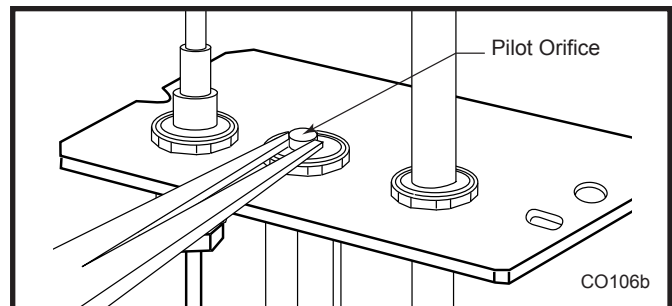


Fig. 55 Remove pilot orifice.

21. Replace burner. Slide the burner in at an angle with left side lower than the right side. Slide the left side onto the injectors, making sure the burner leg remains at a 90° angle to the base. Lower the right hand side down in to place. Make sure the burner is as far left as possible and the injector shoulders are inside the burner.

**NOTE:** It is very critical to keep the left burner leg, which holds the injectors, at a 90° angle to the base. (Fig. 56) This keeps the orifices aligned with the tubes inside burner. Failure to do so could affect the flame appearance and performance of the unit.

22. Place conversion label on valve.
23. Reinstall the right and left log bracket assembly.
24. Reinstall the rear log bracket.

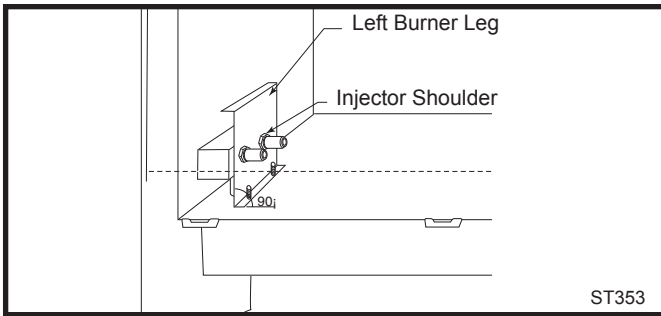


Fig. 56 Be sure to maintain 90° angle at left burner leg.

- 25. Replace logs.
  - 26. Replace glass and stove front.
- Conversion is complete.

<b>Table 2. Injector Orifice Size Matrix</b>						
<b>Conversion to Natural Gas</b>				<b>Input (BTU/h)</b>		
<b>Kit #</b>	<b>Front</b>	<b>Part #</b>	<b>Rear</b>	<b>Part #</b>	<b>Minimum</b>	<b>Maximum</b>
30005155	#54 / .055"	30000514	#44 / .086"	30000334	19,000	28,000
<b>Conversion to LP</b>				<b>Input (BTU/h)</b>		
<b>Kit #</b>	<b>Front</b>	<b>Part #</b>	<b>Rear</b>	<b>Part #</b>	<b>Minimum</b>	<b>Maximum</b>
30005154	#69 / .029"	30000513	#54 / .055"	30000514	20,000	28,000

## Maintenance

Your Gas Heater will provide years of service with minimal upkeep. The following procedures will help ensure that your stove continues to function properly.

### Annual System Inspection

Have the entire heater and venting system inspected annually by a qualified gas technician. Replace any worn or broken parts.

### Logset and Burner / Cleaning and Inspection

Cleanliness is critical to the proper function of the heater. The logset and burner must all be kept free of dust and unobstructed by debris. Inspect these areas before each use and clean as necessary.

1. Turn the burner OFF and let the heater cool completely before cleaning.
2. Lift the Stove Front up and then swing the bottom out to disengage it from the heater shell. (Fig. 57)

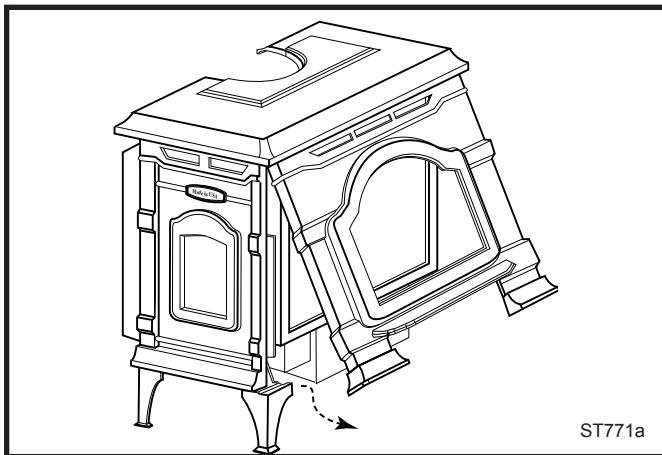


Fig. 57 Remove the stove front.

3. Carefully remove the glass and frame assembly and place it out of the way on a flat, padded surface such as a counter protected by a towel.
4. Carefully inspect the Logs for damage. Contact your local dealer if any damage is evident. **DO NOT OPERATE THE HEATER WITH DAMAGED LOGS.**
5. Use a soft bristled brush to sweep dust or debris from the Logs, Pilot and Burner. Use care as the logs are fragile and susceptible to damage. **DO NOT USE A VACUUM TO CLEAN THE LOGS OR BURNER.**
6. Replace the glass panel and frame assembly.
7. Replace the Stove Front.

### CAUTION

**TURN THE PILOT OFF BEFORE PAINTING. ALLOW THE HEATER TO COOL COMPLETELY BEFORE PAINTING.**

### Care of Cast Iron

An occasional dusting with a dry rag will help keep the painted surfaces looking new. Use high-temperature stove paints, available through your local dealer, to touch-up areas as needed. Clean areas to be painted with a wire brush and be sure to cover the logs, burner and valve assembly, glass and frame assembly. Apply the paint sparingly; two light coats of paint will give better results than a single heavy coat.

Clean porcelain enamel surfaces with a soft, damp cloth. Do not use abrasive cleaning agents. If necessary, use only a cleaning agent formulated especially for use on porcelain enamel surfaces.

### Cleaning the Glass



**WARNING: Allow the glass cool completely before attempting to clean.**



### WARNING



**HOT GLASS WILL CAUSE BURNS.**

**DO NOT TOUCH GLASS UNTIL COOLED.**

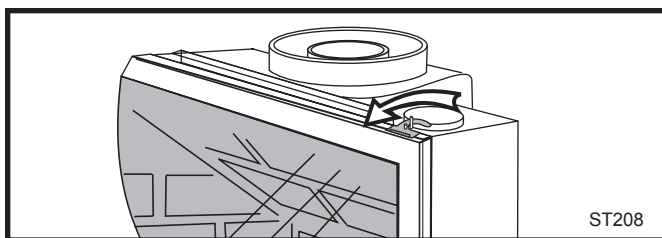
**NEVER ALLOW CHILDREN TO TOUCH GLASS.**

It will be necessary to clean the glass periodically. During start-up, condensation, which is normal, forms on the inside of the glass and causes lint, dust and other airborne particles to cling to the glass surface. Also initial paint curing may deposit a slight film on the glass. It is therefore recommended that the glass be cleaned two or three times with a non-ammonia household cleaner and warm water (we recommend gas fireplace glass cleaner). After that the glass should be cleaned two or three times during each heating season depending on the circumstances present.

**Clean glass after first two weeks of operation.**

### Glass Replacement

Replace glass only with MHSC approved parts. Refer to Page 33 for Replacement Parts. Refer to Figure 58 and previous instructions for removal of the damaged glass frame.



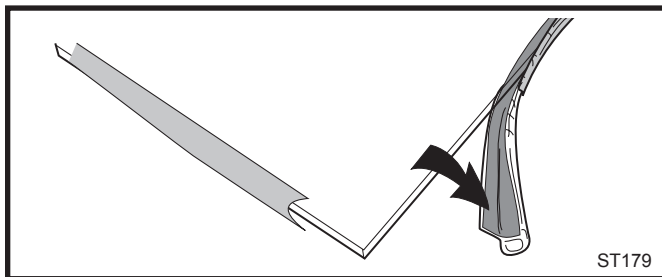
**Fig. 58** Release the latches to release the glass frame.

### Gasket Replacement

The heater uses a 'tadpole' type gasket to seal between the glass panel and the frame. In time, this gasket can become brittle and compressed and should be replaced. New gasket is available from your dealer.

Shut off the gas supply and allow the stove to cool. Wear safety goggles and a dust mask.

1. Remove the Front, Glass Frame and Glass Panel. (Figs. 58 & 59) Remove the old gasket. Use a razor blade to separate the glass and gasket from the frame, and to clean the glass of any remaining cement or bits of gasket. Use a cold chisel if necessary.
2. Determine the correct length of gasket by laying it out around the edge of the glass. Allow an extra 1 - 2" (25-50 mm). Mark the spot to be cut. Use a utility knife.
3. Starting on a long edge, remove about 6" of the protective paper strip and apply the flat adhesive face of the gasket around the outside-facing edge of the panel. Continue around the panel, applying a bout 6" at a time and being careful to not stretch the material. Do not overlap the gasket ends. (Fig. 59)



**Fig. 59** Wrap the gasket material around the outside edge of the glass.

4. Apply a thin bead of high temperature silicone rubber sealant along the inside corner of the glass frame, all around the perimeter. Place the flat gasketed side of the glass panel back into the steel frame. Pinch the rounded inside-facing gasket material to bulk it up.
5. Replace the glass frame and front panel as previously described.

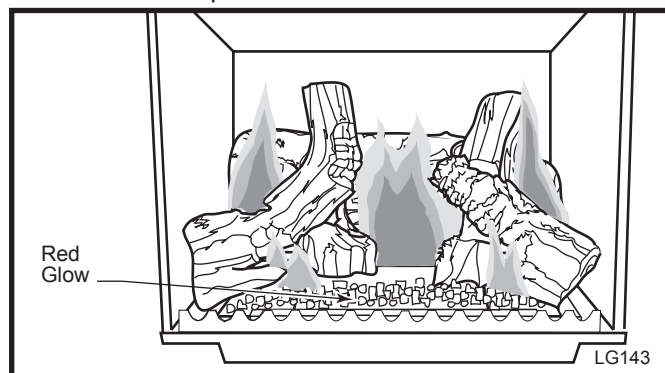
### Inspect the Vent System Annually

Have the vent system inspected annually by a qualified technician. Shut off the main gas supply before inspecting the system. Both the inner exhaust pipe and the outer combustion supply pipe must be checked to confirm that they are unblocked and in good condition.

### Check the Gas Flame Regularly

To ensure that the stove is operating properly, check the flames periodically to confirm they match Figure 60. The flames will be blue during the first 15-20 minutes of operation, and will gradually turn to yellow after that.

Do not use your stove if the flame pattern differs from that shown here. Contact your dealer or a qualified technician for help.



**Fig. 60** Correct flame pattern.

### Stove Disassembly

If there is ever a need to remove the firebox assembly from the stove shell, support the firebox with solid stands about 6" (150 mm) tall under the left and right outer edges of the firebox base. Do not set the firebox assembly directly on the floor; this can damage the control valve and/or the gas lines from the valve to the firebox.

Before removing the firebox from the shell, disconnect the on/off switch wires from the valve. If the assembly includes the optional fan, disconnect the fan rheostat. If the installation includes a wall thermostat, disconnect the thermostat leads from valve.

Disconnection and reconnection to the gas line should only be done by a qualified gas service technician.

Upon reinstallation, the vent system must be sealed to the firebox as shown in the installation section, Page 16. Also be sure the logs are placed in the firebox correctly, as shown in Figures 34 & 35, Page 20.

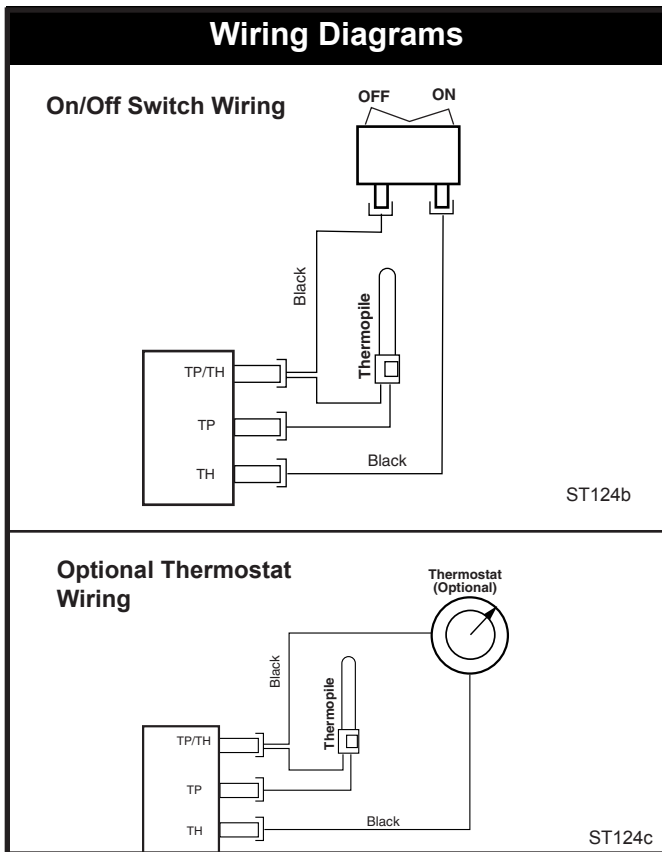


Fig. 61 On/Off switch and optional thermostat circuit.

**NOTE:** IF ANY OF THE ORIGINAL WIRE, AS SUPPLIED WITH THE APPLIANCE, MUST BE REPLACED, IT MUST BE REPLACED WITH TYPE SF-2, 200° WIRE OR ITS EQUIVALENT.

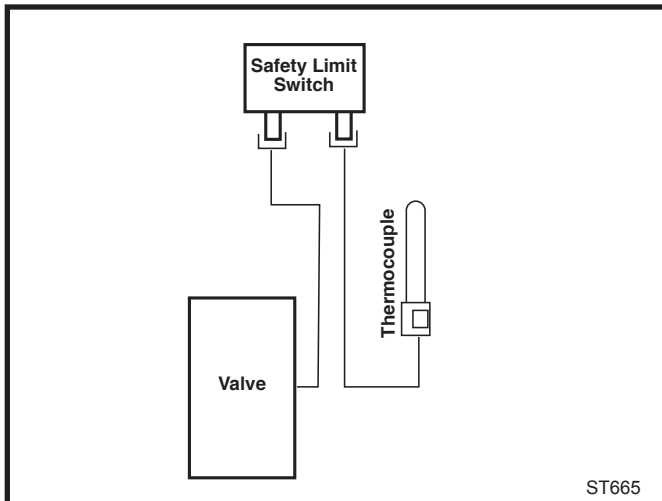


Fig. 62 Draft hood adapter wiring.

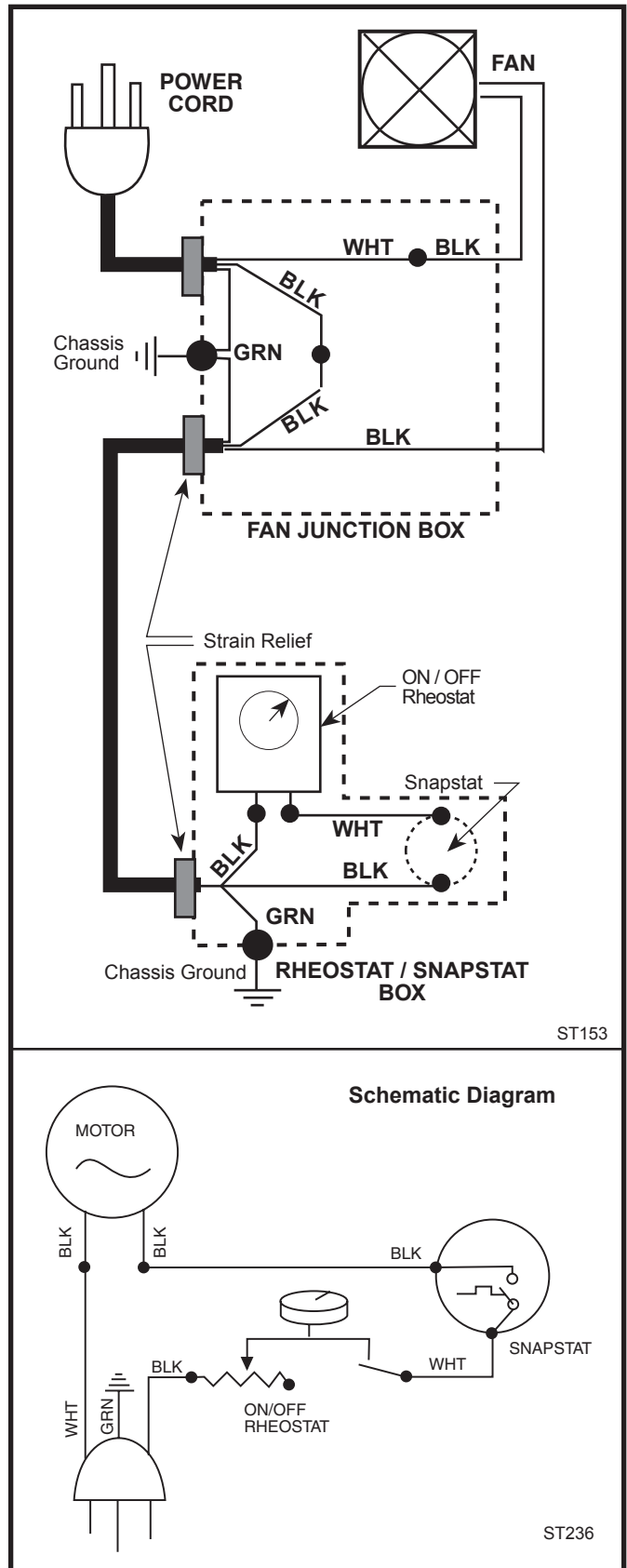
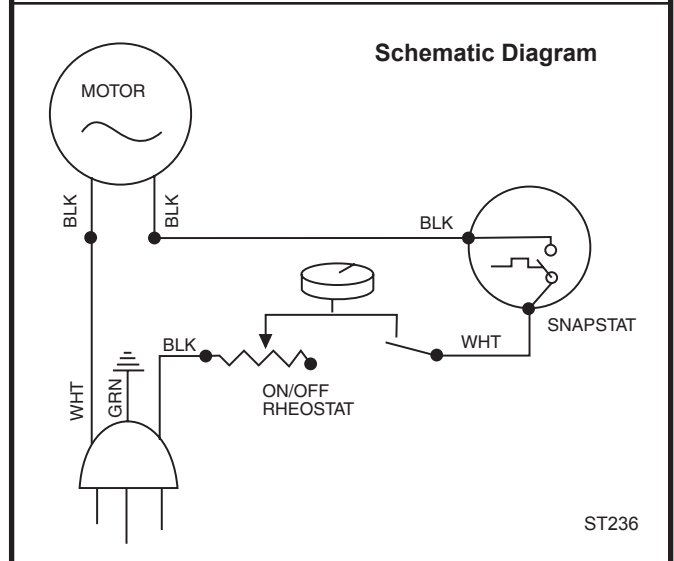
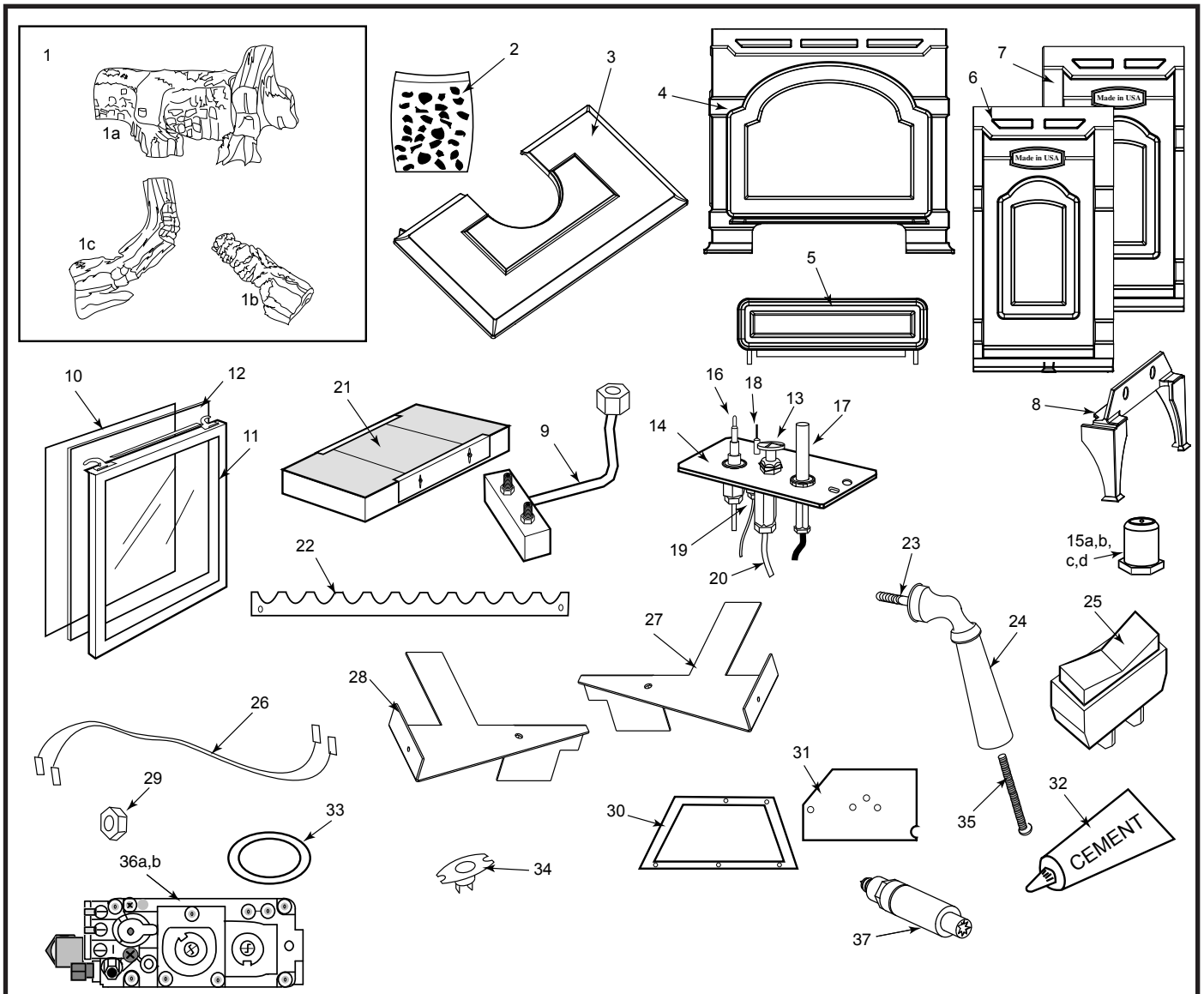


Fig. 63 Fan circuit.







MHSC reserves the right to make changes in design, materials, specifications, prices and discontinue colors and products at any time, without notice.

## Oxford Direct Vent / Natural Vent Gas Heater Models OXDV30NV

Ref.	Description	Oxford
1.	Gas Log Assembly - SDV30	20003458
1a.	Rear Log	20003459
1b.	Right Log	20003460
1c.	Left Log	20003461
2.	Small Lava Rock Package	57897
3.	Top	30001925
4.	Front	30001928
5.	Door	30001929
6.	End, Rt	30001927
7.	End, Lt	30001926
8.	Leg	30001930
9.	Manifold Assembly	20003739

**Oxford Direct Vent / Natural Vent Gas Heater****Models OXDV30NV (continued)**

<b>Ref.</b>	<b>Description</b>	<b>Oxford</b>
10.	Glass, DV25	1601691
11.	Glass Frame Assembly - SDV30	30000127
12.	Gasket, Glass - Med. Knit - RDV40	1203702
13.	Pilot Top Convertible	10002266
14.	Pilot Assembly 3Way N/DV RN 0.199.706	10002264
	Pilot Assembly 3Way N/DV RP 0.199.703	10002265
15a.	Orifice Hood #69 - Front - LP	30000513
15b.	Orifice Hood #54 - Front - NG	20000130
15c.	Orifice Hood #54 - Rear - LP	20000130
15d.	Orifice Hood #44 - Rear - NG	30000334
16.	Thermocouple 24"	24D0808
17.	Thermopile 18" RS	7533113
18.	Electrode Ignitor w/Cable SIT24	10001297
19.	Nut Electrode SIT #0.974.144	57886
20.	Tubing Pilot w/Fittings 1/8 x 24"	10001296
21.	Burner Housing Assembly NG/LP	20002214
22.	Grate, Burner - JDV	20002167
23.	Ashdoor Handle Assy - E/V/WSI	5004241
24.	Handle, Damper - Maple Wood - Blk	1600664
25.	Switch ON/OFF - RN/RP Models	30000874
26.	Wiring Harness - FSDV32 RN/JDV	10002582
27.	Right Log Bracket	20002166
28.	Left Log Bracket	20002165
29.	Nut, Hex Jam 3/8 -16 TOPLK-Z	1203290
30.	Gasket, Base Pan - JDV	20002282
31.	Gasket, Base Pan Inner	20002566
32.	Gasket Cement, 3 oz tube (not shown)	1206122
33.	Gasket, HE Door	1203687
34.	Sensor 2450 CMG-8184-0032	10002013
35.	Pan Hd, SL 1/4-20 x 3-Z	1201310
36a.	Valve Nova SIT820.662 RN (Serial #'s starting with 6414)	20010563
36b.	Valve Nova SIT820.653 RP (Serial #'s starting with 6414)	20010645
37.	Ignitor Piezo w/Nut SIT	057958
38.	Bracket Piezo Ignitor (not shown)	20010876
39.	*Magnet, Control Door (not shown)	1408818

\*Use common super glue or silicone to attach magnets.

**Fuel Conversion Kits**

Conversion Kit, NG to LP - OXDV30NV Kit #30005154

Conversion Kit, LP to NG - OXDV30PV Kit #30005155

## Optional Accessories

### Fan Kits

#### FK26 Fan

The FK26 fan helps distribute heated air from within the firebox out into the room. The fan is controlled by a snapstat that turns power on and off as the firebox temperature rises above and falls below a preset temperature. A rheostat provides for variable fan speeds.

#### Specifications

115 Volt / 60Hz / .75 Amps

#### Maintenance

The fan itself does not require regular maintenance, however, periodic cleaning of the fan and the surrounding area is required.

#### Installation

Refer to Page 14 for installation instructions.

### Remote Controls

The remote control allows you to turn the heater on or off from anywhere in the room. Refer to Page 32 for wiring diagrams.

Model	Functions Controlled
RC1	ON/OFF
RC2	ON/OFF and Temperature
IMTFK	Wall mounted thermostat control

### Decorative Rings

7" brass or charcoal gray rings are available to add a decorative touch to the exposed stove pipe.

Model	Description
7FSDRG/4	7" Charcoal Gray Rings (4)
7FSDRP/4	7" Polished Brass Rings (4)







## LIMITED LIFETIME WARRANTY

### PRODUCT COVERED BY THIS WARRANTY

All MHSC gas stoves equipped with an Insta-Flame Ceramic Burner.

#### BASIC WARRANTY

MHSC (hereinafter referred to collectively as the Company) warrants that your new MHSC Gas Fireplace/Stove is free from manufacturing and material defects for a period of one year from the date of purchase, subject to the following conditions and limitations.

#### EXTENDED LIFETIME WARRANTY

The heat exchanger, where applicable, and combustion chamber of every MHSC gas product is warranted for life against through wall perforation. All appliances equipped with an Insta-Flame Ceramic Burner have limited lifetime coverage on the ceramic burner plaque. Warrantees are made to the original owner subject to proof of purchase and the conditions and limitations listed on this Warranty Document

#### COMPONENT WARRANTY

**CAST IRON:** All external and internal cast iron parts are warranted for a period of three years.

**Note:** On porcelain enamel finished external parts and accessories The Company offers no Warranty on chipping of enamel surfaces. Inspect all product prior to accepting it for any damage to the enamel.

The salt air environment of coastal areas or a high humidity environment can be corrosive to the porcelain enamel finish. These conditions can cause rusting of the cast iron beneath the porcelain enamel finish, which will cause the finish to flake off.

Dye lot variations with replacement parts and/or accessories can occur and are not covered by warranty.

**GLASS DOORS:** Glass doors are covered for a period of one year. Glass doors are not warranted for breakage due to misuse or accident. Glass doors are not covered for discoloration or burned in stains due to environmental issues, or improper cleaning and maintenance.

**BRASS PLATED PARTS AND ACCESSORIES:** Brass parts should be cleaned with Lemon oil only. Brass cleaners cannot be used. Mortar mix and masonry cleaners may corrode the brass finish. The Company will not be responsible for, nor will it warrant any brass parts which are damaged by external chemicals or down draft conditions.

**GAS VALVES:** Gas valves are covered for a period of one year

**ELECTRONIC AND MECHANICAL COMPONENTS:** Electronic and mechanical components of the burner assembly are covered for one year. All steel tube burners are warranted for one year.

**ACCESSORIES:** Unless otherwise noted all components and MHSC company supplied accessories are covered for a period of one year.

#### CONDITIONS AND LIMITATIONS

- This new MHSC product must be installed by a competent, authorized, service contractor. A licensed technician, as prescribed by the local jurisdiction must perform any installation/service work. It must be installed and operated at all times in accordance with the Installation and Operating instructions furnished with the product. Any alteration, willful abuse, accident, or misuse of the product shall nullify this warranty.
- This warranty is non-transferable, and is made to the original owner, provided that the purchase was made through an authorized supplier of the Company.
- The customer must pay for any Authorized Dealer in-home travel fees or service charges for in-home repair work. It is the dealers option whether the repair work will be done in the customer's home or in the dealer's shop.
- If upon inspection, the damage is found to be the fault of the manufacturer, repairs will be authorized at no charge to the customer parts and/or labor.
- Any part and/or component replaced under the provisions of this warranty is covered for six months or the remainder of the original

warranty, whichever is longest.

- This warranty is limited to the repair of or replacement of part(s) found to be defective in material or workmanship, provided that such part(s) have been subjected to normal conditions of use and service, after said defect is confirmed by the Company's inspection.
- The company may, at its discretion, fully discharge all obligations with respect to this warranty by refunding the wholesale price of the defective part(s)
- Any installation, labor, construction, transportation, or other related costs/expenses arising from defective part(s), repair, replacement, or otherwise of same, will not be covered by this warranty, nor shall the Company assume responsibility for same. Further, the Company will not be responsible for any incidental, indirect, or consequential damages except as provided by law.
- *SOME STATES DO NOT ALLOW FOR THE EXCLUSION OR LIMITATIONS OF INCIDENTAL AND CONSEQUENTIAL DAMAGES OR LIMITATIONS ON HOW LONG AN IMPLIED WARRANTY LASTS, SO THE ABOVE LIMITATIONS MAY NOT APPLY TO YOUR CIRCUMSTANCES. THIS WARRANTY GIVES YOU SPECIFIC RIGHTS AND YOU MAY HAVE OTHER RIGHTS WHICH VARY FROM STATE TO STATE.*
- All other warranties-expressed or implied- with respect to the product, its components and accessories, or any obligations/liabilities on the part of the Company are hereby expressly excluded.
- The Company neither assumes, nor authorizes any third party to assume on its behalf, any other liabilities with respect to the sale of this MHSC product
- The warranties as outlined within this document do not apply to chimney components or other non MHSC accessories used in conjunction with the installation of this product..
- Damage to the unit while in transit is not covered by this warranty but is subject to claim against the common carrier. Contact the dealer from whom you purchased your fireplace/stove (do not operate the appliance as this might negate the ability to process the claim with the carrier).
- The Company will not be responsible for:
  - a) Down drafts or spillage caused by environmental conditions such as near-by trees, buildings, roof tops, hills, or mountains.
  - b) Inadequate ventilation or negative air pressure caused by mechanical systems such as furnaces, fans, clothes dryers, etc.
- This warranty is void if:
  - a) The fireplace has been operated in atmospheres contaminated by chlorine, fluorine, or other damaging chemicals.
  - b) The fireplace has been subjected to prolonged periods of dampness or condensation
  - c) Any damages to the fireplace, combustion chamber, heat exchanger or other components due to water, or weather damage, which is the result of but not limited to, improper chimney/venting installation.
  - d) Any alteration, willful abuse, accident, or misuse of the product has occurred.

#### IF WARRANTY SERVICE IS NEEDED...

- 1) Contact your supplier. Make sure you have your warranty, your sales receipt, and the model/serial number of your MHSC product.
- 2) DO NOT ATTEMPT TO DO ANY SERVICE WORK YOURSELF.

Canada

# ENERGUIDE

Look for the **EnerGuide**  
Gas Fireplace Energy  
Efficiency Rating in this brochure

*Based on CSA P.4.1-02*

## Efficiency Ratings

Model	EnerGuide Ratings Fireplace Efficiency (%)
OXDV30NV	63.0
OXDV30PV	63.0

NATIONAL  
FIREPLACE  
INSTITUTE



CERTIFIED  
[www.nficertified.org](http://www.nficertified.org)

We recommend that our gas hearth products be installed and serviced by professionals who are certified in the U.S. by the National Fireplace Institute® (NFI) as NFI Gas Specialists.

**MHSC**

149 Cleveland Drive • Paris, Kentucky 40361  
[www.mhsc.com](http://www.mhsc.com)