



# 24,000 BTU/H WALL MOUNTED HEAT PUMP SYSTEM

SUBMITTAL COVER SHEET

PROJECT NAME \_\_\_\_\_

LOCATION \_\_\_\_\_



ARCHITECT \_\_\_\_\_

ENGINEER \_\_\_\_\_

CONTRACTOR \_\_\_\_\_

REFERENCE \_\_\_\_\_

SUBMITTED BY \_\_\_\_\_ DATE \_\_\_\_\_

Indoor Unit (IDU): DRAW24F1B	Outdoor Unit (ODU): DRA1U24S1B	Wireless Remote Control
		

## PRODUCT FEATURES

- Wireless Remote Control with "Follow Me" Technology
- Variable Speed Inverter Compressor
- Auto Restart
- Sleep Mode
- Turbo Mode
- 24-Hour Timer Feature
- Quiet operation
- 46°F Freeze Protection
- Low ambient heating down to -13 °F
- Low ambient cooling down to 5 °F
- Included base pan heater
- Refrigerant leak detection
- Anti-corrosive fin coating

SYSTEM DATA	
Refrigerant Type	R-410A
Refrigerant Charge (oz.)	82.89
Design Pressure (PSIG)	550/340
Indoor/ Outdoor Coil Coating	Golden Fin Coating

EFFICIENCY DATA	
SEER2	21.0
EER2	13.0
HSPF2	8.5
SEER	21.0
EER	13.0
HSPF	10.0
COP at 47 °F	3.15
COP at 5 °F	2.04

CAPACITIES		
Cooling Capacity (BTU/hr)	Rated at 95 °F	24000
	Sensible at 5 °F <sup>3</sup>	20910
	Minimum	9200
	Maximum	25000
Heating Capacity (BTU/hr)	Rated at 47 °F	26000
	Maximum at 5 °F <sup>4</sup>	17600
	Minimum	10350
	Maximum	26410





# 24,000 BTU/H WALL MOUNTED HEAT PUMP SYSTEM

SPECIFICATIONS

LINE SET REQUIREMENTS	
Connection Type	Flare
Liquid	Ø3/8" (Ø9.52mm)
Gas	Ø5/8" (Ø16mm)
Pre-Charge Length	25'
Minimum Length	10'
Maximum Length	164'
Maximum Height Differential	82'
Additional Refrigerant (oz./ft)	0.32

OUTDOOR UNIT		
Unit Dimensions	Width	37 1/4"
	Depth	16 1/8"
	Height	31 7/8"
Carton Dimensions	Width	42 15/16"
	Depth	19 11/16"
	Height	34 13/16"
Net Weight	124.8 lbs.	
Gross Weight	134.9 lbs.	
Cooling Operating Temperature	5 °F - 122 °F	
Heating Operating Temperature	-13 °F - 86 °F	
Voltage/Phase/Frequency	208-230V, 1 Phase, 60 Hz	
Voltage Range	187-253V	
Recommended Breaker (Amps)	30	
Minimum Circuit Ampacity (Amps)	22	
Communication Wire Size	14*4 AWG Stranded	
Rated Current - Cooling (Amps) <sup>1</sup>	8.02	
Rated Current - Heating (Amps) <sup>2</sup>	10.35	
Sound Pressure (dB(A))	60	

INDOOR UNIT		
Unit Dimensions	Width	42 5/8"
	Depth	9 3/16"
	Height	13 1/4"
Carton Dimensions	Width	45 1/2"
	Depth	12 3/8"
	Height	16 5/16"
Net Weight	30.0 lbs.	
Gross Weight	39.1 lbs.	
Indoor Unit Air Flow (CFM)	Low	382
	Medium	459
	High	601
Moisture Removal (Pints/day)	131.52	
Drain Port O.D.	Ø5/8" (Ø16mm)	
Recommended Breaker (Amps)	15	
Sound Pressure (dB(A))	Low	28
	Medium	40
	High	48

COMPRESSOR	
Type	DC Inverter Twin Cylinder Rotary
Oil Type	Ester Oil VG74
Oil Charge (oz.)	21 oz.(620 ml)

<sup>1</sup> Measured at 95 °F.

<sup>2</sup> Measured at 47 °F.

<sup>3</sup> Sensible Capacity: Indoor 80 °F DB, 67 °F WB // Outdoor 5 °F DB, 4 °F WB

<sup>4</sup> Maximum Capacity: Indoor 70 °F DB, 67 °F WB // Outdoor 5 °F DB, 4 °F WB



# 24,000 BTU/H WALL MOUNTED HEAT PUMP SYSTEM

IDU DIMENSIONS - DRAW24F1B

## Unit Dimensions

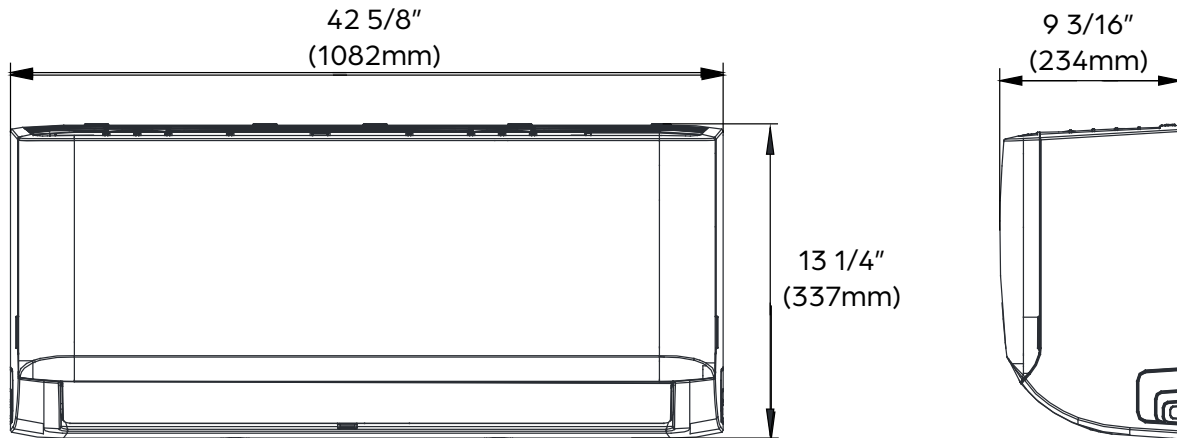

## Mounting Plate Dimensions

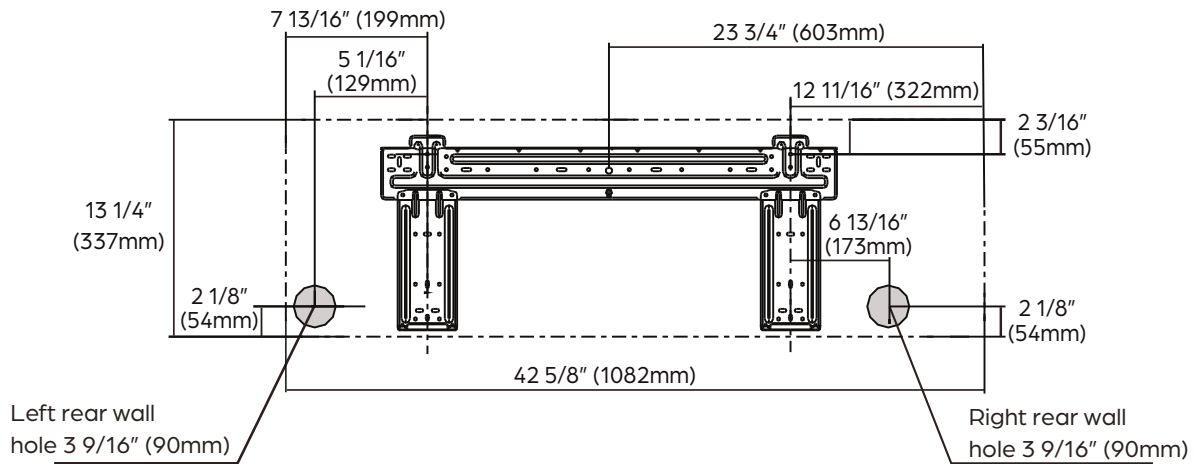

## Clearance Distances

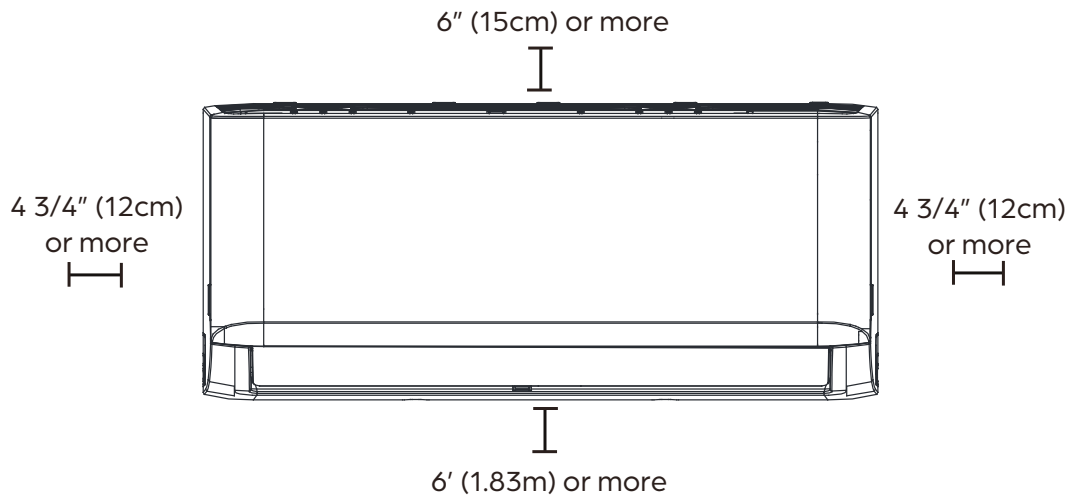



# 24,000 BTU/H WALL MOUNTED HEAT PUMP SYSTEM

ODU DIMENSIONS - DRA1U24S1B

## Clearances

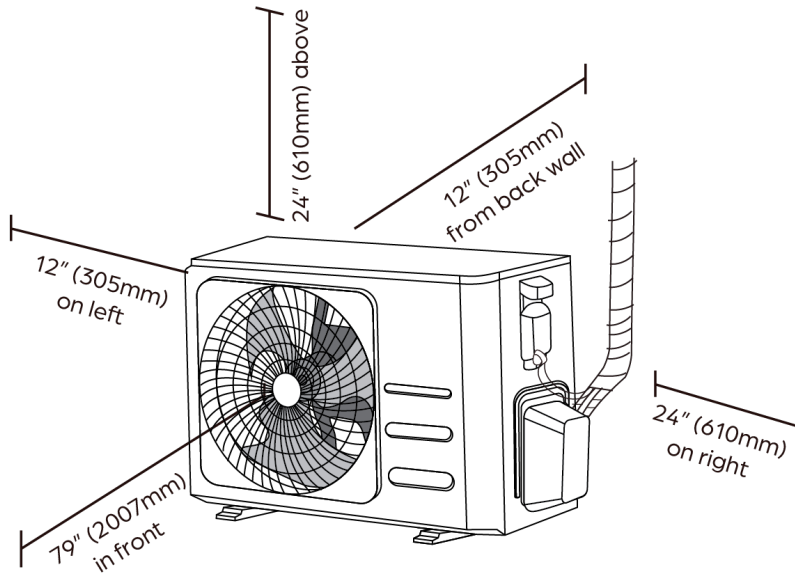

## Dimensions

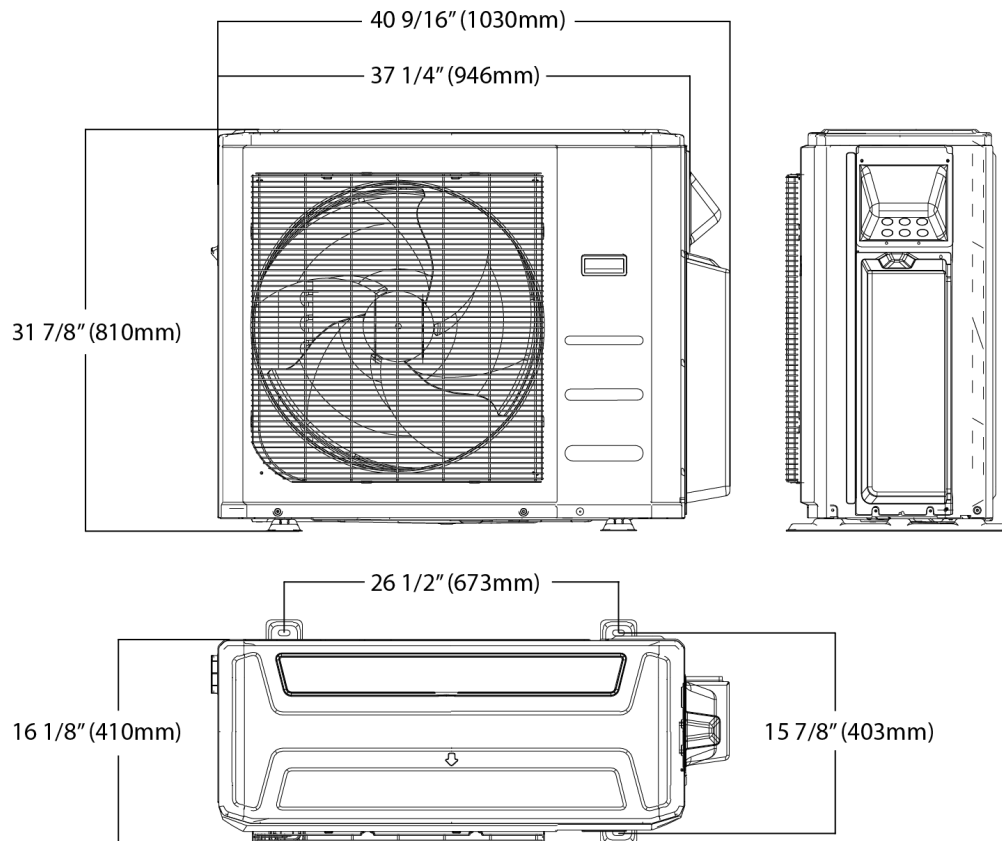

### NOTE

Illustrations in this document are for explanatory purposes. The actual shape of your mini-split equipment may vary slightly.