

SPECIFICATIONS & SUBMITTAL DATA

FEATURES:

- Thermostat, pumps & motor included
- Automatic dump system
- Heavy gauge galvanized steel cabinet
- Electrostatically applied polyester powder coating finish
- Thermoplastic water reservoir and plastic media shield prevent water from contacting metal cabinet
- Long life efficient media
- Removable wet section for easier installation
- Perforated prefilter screen provides greater airflow for better cooling
- Low maintenance and trouble free



MODELS

- AD1C51, AD2C51**
AS1C51, AS2C51
AU1C51, AU2C51
AD1C5112, AD2C5112
AS1C5112, AS2C5112
AU1C5112, AU2C5112

AD1C71, AD2C71
AS1C71, AS2C71
AU1C71, AU2C71
AD1C7112, AD2C7112
AS1C7112, AS2C7112
AU1C7112, AU2C7112

Project

Location

Architect

Engineer

Contractor

Submitted By _____ Date _____

Ref. No.	Cooler Model No.	Qty.	CFM	Static Pressure	Motor	HP	Speed	Volts	Phase	Optional Accesories
1										
2										
3										
4										
5										
6										
7										
8										
9										

Notes

CHAMPION COOLER
 5800 Murray, Little Rock, AR 72209
 1-800-643-8341
 info@championcooler.com

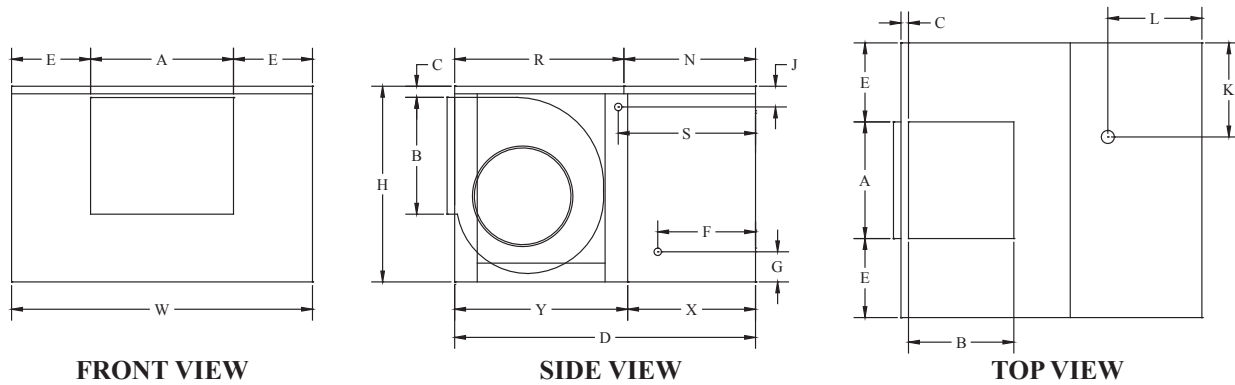

FRONT VIEW

SIDE VIEW

TOP VIEW

CABINET DIMENSIONS*																					
Model No.	General Dimensions			Duct				Water Service Location	Electrical Service Location	Drain Location		Module Length		Belt Length	Blower Wheel			Weight (lbs.)			
				Opening		Location				K	L	X	Y		Dia.	Width	Shaft	Oper.	Ship.		
	H	W	D	A	B	C	E	F	G	S	J	K	L	X	Y	Dia.	Width	Shaft	Oper.	Ship.	
AD1C51 AD2C51	28	42	45	17 3/4	17 3/4	1 1/2	12 1/8	13	5 3/4	20 3/8	3 9/16	17	14 1/16	18 1/4	26 3/4	53	16	16 3/4	1	233	184
AS1C51 AS2C51	28	42	45	17 3/4	17 3/4	1 1/2	12 1/8	13	5 3/4	20 3/8	3 9/16	17	14 1/16	18 1/4	26 3/4	57	16	16 3/4	1	233	184
AU1C51 AU2C51	28	42	45	17 3/4	17 3/4	1 1/2	12 1/8	13	5 3/4	20 3/8	3 9/16	17	14 1/16	18 1/4	26 3/4	51	16	16 3/4	1	233	184
AD1C5112 AD2C5112	28	42	49	17 3/4	17 3/4	1 1/2	12 1/8	17	5 3/4	24 3/8	3 9/16	17	18 1/16	22 1/4	26 3/4	53	16	16 3/4	1	263	204
AS1C5112 AS2C5112	28	42	49	17 3/4	17 3/4	1 1/2	12 1/8	17	5 3/4	24 3/8	3 9/16	17	18 1/16	22 1/4	26 3/4	57	16	16 3/4	1	263	204
AU1C5112 AU2C5112	28	42	49	17 3/4	17 3/4	1 1/2	12 1/8	17	5 3/4	24 3/8	3 9/16	17	18 1/16	22 1/4	26 3/4	51	16	16 3/4	1	263	204
AD1C71 AD2C71	34 5/8	42	48	19 3/4	19 3/4	1 1/2	11 1/8	13	5 3/4	20 3/8	3 9/16	17	14 1/16	18 1/4	29 3/4	64	20	16 3/4	1	269	220
AS1C71 AS2C71	34 5/8	42	48	19 3/4	19 3/4	1 1/2	11 1/8	13	5 3/4	20 3/8	3 9/16	17	14 1/16	18 1/4	29 3/4	67	20	16 3/4	1	269	220
AU1C71 AU2C71	34 5/8	42	48	19 3/4	19 3/4	1 1/2	11 1/8	13	5 3/4	20 3/8	3 9/16	17	14 1/16	18 1/4	29 3/4	67	20	16 3/4	1	269	220
AD1C7112 AD2C7112	34 5/8	42	52	19 3/4	19 3/4	1 1/2	11 1/8	17	5 3/4	24 3/8	3 9/16	17	18 1/16	22 1/4	29 3/4	64	20	16 3/4	1	306	246
AS1C7112 AS2C7112	34 5/8	42	52	19 3/4	19 3/4	1 1/2	11 1/8	17	5 3/4	24 3/8	3 9/16	17	18 1/16	22 1/4	29 3/4	67	20	16 3/4	1	306	246
AU1C7112 AU2C7112	34 5/8	42	52	19 3/4	19 3/4	1 1/2	11 1/8	17	5 3/4	24 3/8	3 9/16	17	18 1/16	22 1/4	29 3/4	67	20	16 3/4	1	306	246

ELECTRICAL SPECIFICATIONS						CFM*** INCHES STATIC PRESSURE						
Models	HP	Speeds	Phase	Volts	Amps**	0"	0.1"	0.2"	0.3"	0.4"	0.5"	0.6"
AD1C51 AS1C51 AU1C51	3/4	2	1	115	14.9	3788	3630	3450	3260	3020	2806	2570
AD2C51 AS2C51 AU2C51												
AD1C5112 AS1C5112 AU1C5112	3/4	2	1	115	14.9	3606	3472	3317	3135	2918	2661	2379
AD2C5112 AS2C5112 AU2C5112												
AD1C71 AS1C71 AU1C71	1	2	1	115	17.1	5024	4820	4630	4450	4280	4100	3900
AD2C71 AS2C71 AU2C71												
AD1C7112 AS1C7112 AU1C7112	1	2	1	115	17.1	4941	4747	4572	4394	4208	3996	3749
AD2C7112 AS2C7112 AU2C7112												

* All Dimensions in inches.

** Blower motor (high speed) and pumps. Amp rating is Full-Load Amperage per National Electric Code.

*** Cubic feet per minute.