

BI98 • 15" Crescent Ice Maker • ADA Series

FEATURES & BENEFITS



BLACK
SOLID



WHITE
SOLID

PERFORMANCE	<ul style="list-style-type: none"> • Uses less than 3 gallons of water to produce up to 25 lbs of ice per day • Up to 25 lbs in ice storage capacity • Daily ice production rate is approx. 4 times greater than the average household refrigerator • Crescent ice cube dimensions: 1/2" W x 3/4" H x 2 1/4" L • On/Off switch is conveniently located on the grille
INTERIOR/EXTERIOR	<ul style="list-style-type: none"> • No drain required • Door swing is field reversible, and is shipped right-hand hinged
INTEGRATION	<ul style="list-style-type: none"> • Unit is designed to be built-in or can be freestanding • Accepts a 1/4" custom insert panel • Available in the following finishes: Black or White

MODEL DETAILS

Model	Voltage/Hz	Door Swing	Finish	Shipping Weight
U-BI98B-00A	115 / 60	Field Reversible	Black Solid	73 lb
U-BI98W-00A	115 / 60	Field Reversible	White Solid	73 lb

ACCESSORIES

Model	Description	Finish	Shipping Weight
80-54674-00	Braided water supply line kit	N/A	2 lb

ADA Series • 15" Crescent Ice Maker • BI98
DIMENSIONS

Dimensions shown apply to all finishes.

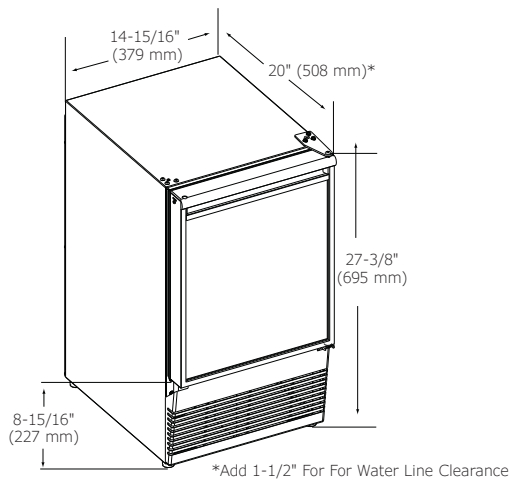
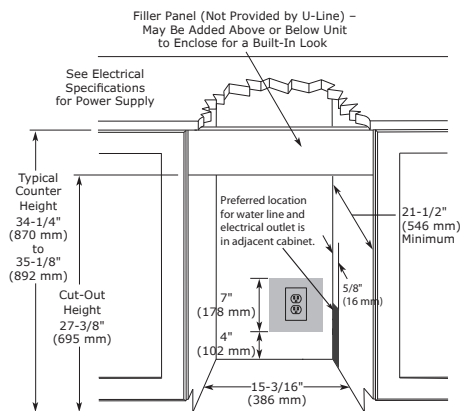
CABINET CUT-OUT

INSTALLATION NOTES

No additional clearance around sides, top or rear of unit is needed for ventilation.

Do not obstruct front grille air flow.

SPECIFICATIONS

Model	BI98
Amps: Running	2.5
Control Type	On/Off Switch
Defrost Type	Manual
Dimensions: Product Depth	20" / 508 mm
Dimensions: Product Height	27 3/8" / 695 mm
Dimensions: Product Width	14 15/16" / 379 mm
ENERGY STAR	N/A
Panel Type	Insert
Panel Thickness	1/4" (6.3 mm)
Panel Height	15 15/16" (405 mm)
Panel Width	13 15/16" (354 mm)
Ice Production Per Day	25 lb
Ice Storage	25 lb
Product Weight: Max	67 lb
Refrigerant Type	R134a
Sabbath (Star K Certified)	No

ELECTRICAL REQUIREMENTS

This unit requires a grounded, polarized 115 VAC, 60 Hz, 15 A power supply (normal household current).



Warranty

Please visit u-line.com to view this model's User Guide & Service Manual. All Specifications are subject to change without notice.