

EDGESTAR[®]

Dehumidifier

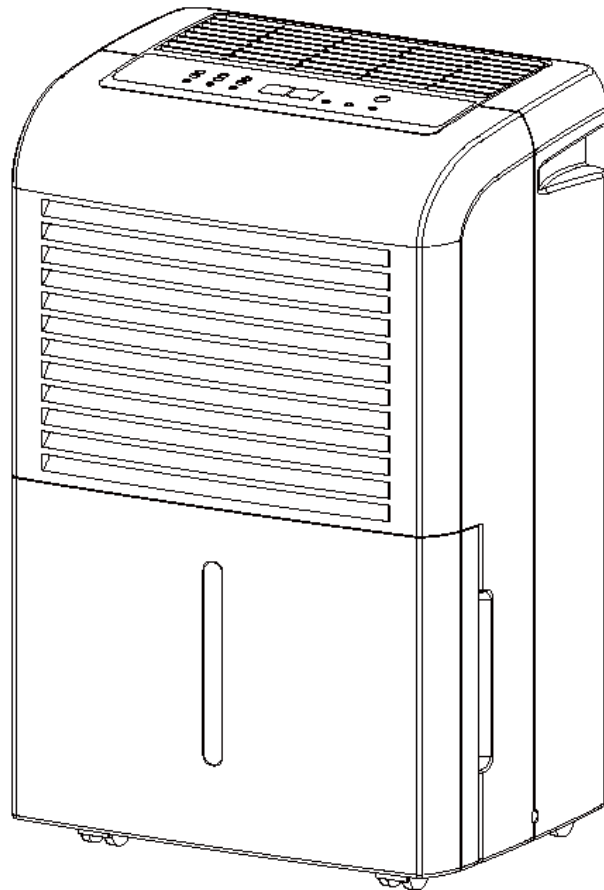

DEP501WP / DEP701WP

Owner's Manual

*For more information on other great EdgeStar products on the web, go to <https://www.edgestar.com>
To use the EdgeStar self-diagnostic tool, go to <https://support.edgestar.com>*

Important Safety Information



Warning: The water produced by the dehumidifier is not potable or suitable for drinking.

Do not drink or use condensate or water drained from the unit as it contains contaminants and could make you sick.

Improper handling can cause serious damage to the EdgeStar dehumidifier and/or injury to the user. This dehumidifier is designed for domestic indoor use only. Do not use the unit for industrial or commercial use. Any other use may invalidate the warranty. Please review the ratings label located on the rear panel of the unit for electrical and other technical data related to this unit. The unit must be connected to a properly grounded wall outlet. Please read and follow the safety information listed below.



Electrical Safety

- This dehumidifier is designed for indoor use only. Do not use the unit near bath tubs, swimming pools or other bodies of water.
- Do not wet the housing or control panel.
- Do not exceed the power outlet ratings.
- Do not pull the unit by the cord.
- Always turn the unit off and unplug it from the outlet when cleaning.
- Unplug the unit if it is not going to be used for an extended time period.
- Do not operate the unit with a power plug missing the ground plug, a damaged cord, or a loose socket.
- Be sure the dehumidifier is properly grounded.
- Never plug or unplug the unit with wet hands.
- Do not bypass, cut, or remove the grounding plug.
- Do not use extension cords or power strips with this unit. You may need to contact your electrician if it is necessary to use a longer cord or you do not have a grounded outlet. Do not modify the power cord's length or share the outlet with other appliances. It is recommended the unit be connected on its own circuit.
- Do not start or stop the unit by switching the circuit's power on and off.
- If the power cord is damaged, it must be replaced by the manufacturer or a qualified technician.
- Never open the unit while it is plugged in.
- Immediately unplug the unit if it makes strange sounds, emits smells, or smoke comes out of it, and contact customer service.
- Do not remove any part of the casing unless instructed to do so by an authorized technician.
- You should never attempt to repair the unit yourself.



Note: Electrical products should not be disposed of with household waste. Please contact your local recycling center for more information on how to recycle electronic waste.





General Safety

- This unit is not intended to be used by children.
- Children should be supervised to ensure that they do not play with this product.
- Do not allow children to play with the controls or drop any objects into the air outlets or vents.
- Care should be taken when using the unit in a room with infants, elderly persons, and children.
- Do not place flower vases, containers, or any objects on top of the unit.
- Do not allow anyone to sit on the unit.
- Do not climb on or use the unit as a step.
- Do not cover the air intake or exhaust vents with towels, clothes, or materials that prevent airflow.
- When using the unit in closets or confined spaces, be sure to keep doors open to allow proper ventilation.
- Do not use this appliance near flammable gas or combustibles, such as gasoline, benzene, thinner, etc.
- Do not use the unit in areas where chemicals are handled.
- Do not place the unit near a heat source as doing so may cause the plastic parts to melt.
- Only use in an upright position on a flat, level surface and provide at least 10 inches of clearance from any walls or objects.
- Route the power cord carefully to avoid creating a tripping hazard.
- When using in closets or confined spaces, be sure to keep doors open to allow proper ventilation.
- Clean the pre-filter regularly. A clogged pre-filter can restrict proper airflow and reduce the lifespan and/or efficiency of this unit.
- Never run the unit without a pre-filter.

Table of Contents

IMPORTANT SAFETY INFORMATION	I
TABLE OF CONTENTS	III
INTRODUCTION	1
PARTS IDENTIFICATION	2
FRONT VIEW.....	2
BACK VIEW.....	2
INSTALLATION INSTRUCTIONS	3
CONTROL PANEL OVERVIEW	4
OPERATING THE CONTROL PANEL.....	5
<i>Power</i>	5
<i>Timer</i>	5
<i>Fan Speeds</i>	5
<i>Setting the Humidity Level</i>	5
<i>LED Display</i>	6
<i>Water Full Light</i>	6
<i>Additional Notes About the Dehumidifier's Behavior</i>	6
DRAINING THE UNIT	7
PUMP DRAIN.....	7
MANUAL DRAIN.....	8
CONTINUOUS GRAVITY DRAIN.....	8
MAINTENANCE	9
CLEANING THE UNIT.....	9
CLEANING THE PRE-FILTER.....	9
CLEANING THE WATER BUCKET.....	10
PREPARATION FOR STORAGE.....	10
AUTO-DEFROST	10
ENERGY SAVING GUIDE	10
TROUBLESHOOTING	11
SPECIFICATIONS	13
EDGESTAR LIMITED WARRANTY	14

Introduction

Thank you for purchasing this EdgeStar dehumidifier. We hope that this purchase will be the beginning of a lasting and rewarding relationship between you and EdgeStar. We will provide the customer support and exemplary products necessary to nurture that relationship.

This manual contains important information regarding the proper installation, use, and maintenance of your dehumidifier. Following this manual will ensure that your product will work at its peak performance, efficiency, and safety.

Please save the original product packaging in case you need to safely transport your dehumidifier.

For Your Records:

Please write down the model number and serial number below for future reference. Both numbers are located on the ratings label on the back of your unit and are needed to obtain warranty service. You may also want to staple your receipt to this manual as it is the proof of your purchase, and is also needed for service under your warranty.

Model Number: _____

Serial Number: _____

Date of Purchase: _____

For a more efficient experience, please do the following before contacting customer service:

- If you received a damaged product, immediately contact the dealer that sold you the product.
- Read and follow this instruction manual carefully to help you install, use, and maintain your dehumidifier.
- Read the troubleshooting section of this manual as it will help you diagnose and solve common issues.
- Visit us on the web at <https://www.edgestar.com> for product guides, additional troubleshooting resources and up-to-date information. You can also find an interactive self-diagnostic tool at <https://support.edgestar.com>. If you need service, our friendly customer service representatives are available via email at **service@edgestar.com**.

Parts Identification

Front View

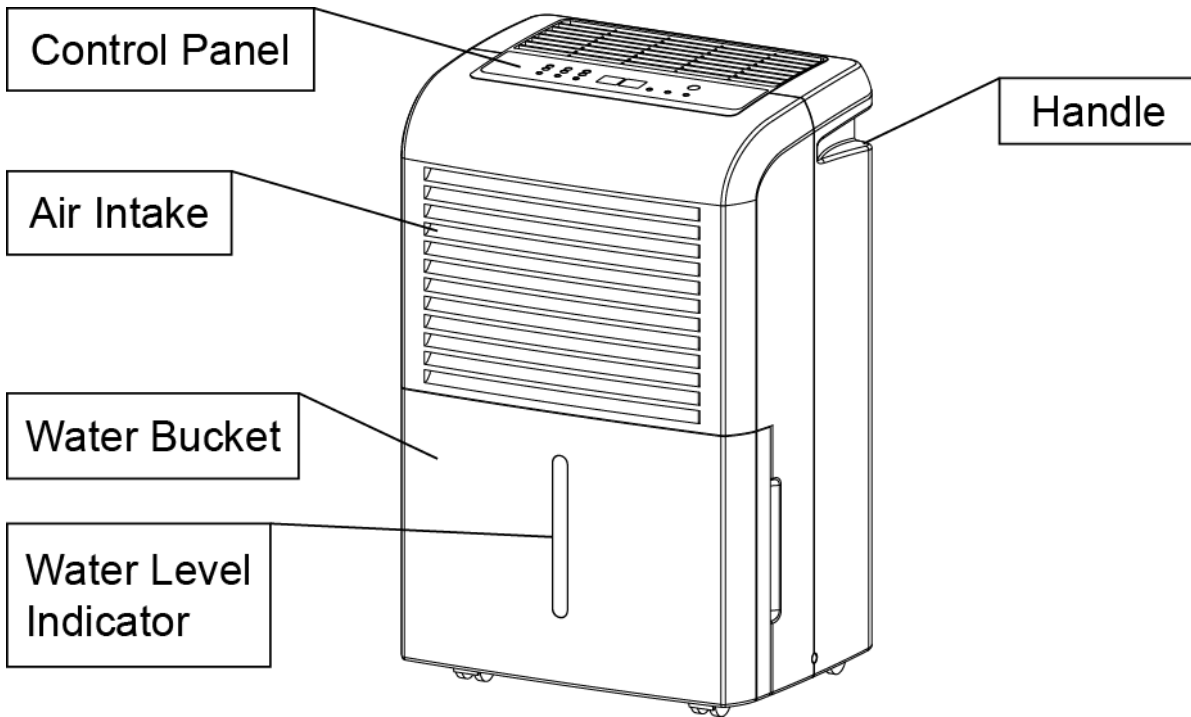

Back View

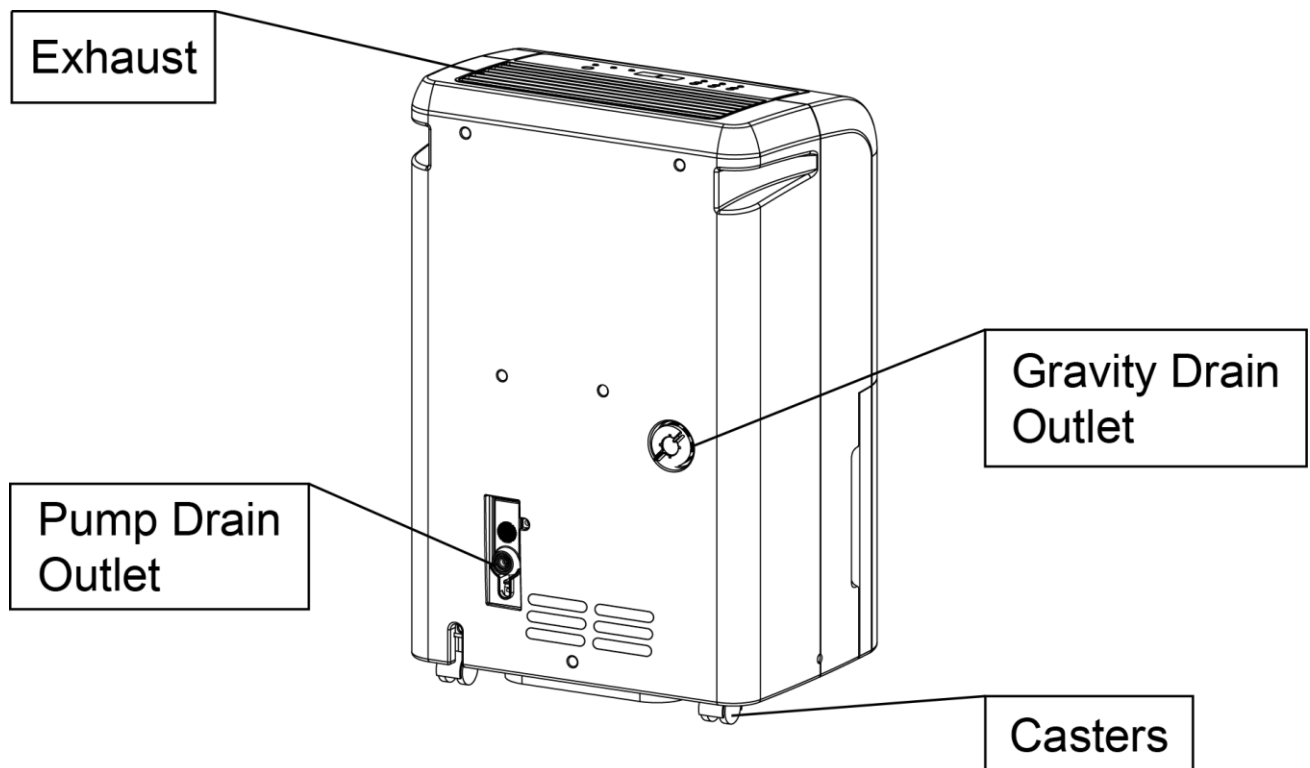

Installation Instructions



Note:

- Dehumidifiers working in a basement will have little or no effect on adjacent enclosed rooms such as closets, unless there is enough circulation of air in and out of the enclosed area.
- The unit is designed to work in environments with temperatures between 41°F and 95°F.

You can use the EdgeStar dehumidifier to create a comfortable environment and prevent damage caused by moisture to books or valuables in areas such as basements or home libraries. Follow the instructions below to unpack and set up your unit.

1. Carefully unpack the dehumidifier from its box and packaging material, and remove any adhesive tape holding the water bucket and filter in place. You may want to save the box for storing and transporting the unit. Let the unit sit upright for at least 24 hours before powering it on to allow the compressor's fluids to settle.
2. Place the dehumidifier on a level floor or surface that is strong enough to support the unit with a full bucket of water in a room where the ambient temperature will not drop below 41°F, and away from any heat sources such as direct sunlight, heaters, radiators, dryers, etc.

Allow at least 10 inches of space all around the unit and at least 20 inches of space above the unit.

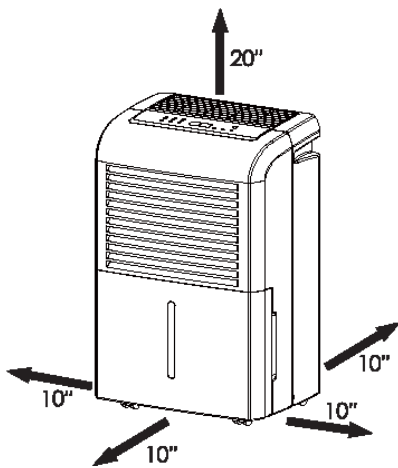

If you have multiple power outlets in the room, choose one that is near the dehumidifier and that will be able to provide adequate power to the unit. See the power requirements listed in the product label located on the side, or on the back of your dehumidifier.

3. Close all windows and doors. To be most effective, use the dehumidifier in a contained room as opposed to a partitioned studio or warehouse type space.
4. To activate the unit and ensure the warning switches are engaged, remove the water bucket and reinstall it; otherwise, the unit may not work properly.
5. Plug the unit in to a grounded outlet. (Read the "Safety Information" section.)



Caution: This unit is for freestanding, indoor use only and will not operate correctly if used outdoors or if built in under a counter or cabinet.

Control Panel Overview

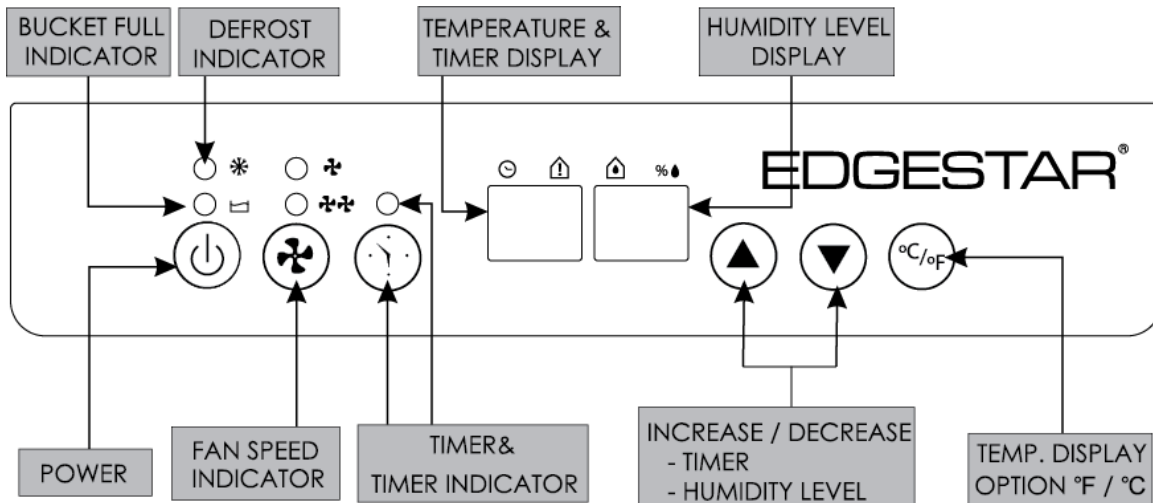

Button	Function
	Powers the unit on or off.
	Adjusts the fan speed.
	Activates the timer mode.
	Increases the desired relative humidity setting for damper air. <u>Note:</u> When in Timer Mode, this button will increase the Timer setting in increments of 1 hour.
	Decreases the desired relative humidity setting for drier air. <u>Note:</u> When in Timer Mode, this button will decrease the Timer setting in increments of 1 hour.
	Adjusts the temperature display to be shown in Celsius (C) or Fahrenheit (F).



Note: This unit is not a humidifier; using the increase humidity button will not add moisture to the air.

Indicator Light	Function
Bucket Full	Lights up to indicate that the water bucket is full and must be emptied.
Timer	Lights up to indicate that the unit is in timer mode.
High Speed	Lights up to indicate the fan is on the high setting.
Normal Speed	Lights up to indicate the fan is on the normal setting.
Defrost Indicator	Lights up to indicate the auto defrost operation is on.

Display	Function
Temperature / Timer Display	Displays the current temperature. When adjusting the Timer setting, displays the time setting in hours then reverts back to current temperature after 10 seconds.
Humidity Level Display	Displays the level of humidity. Displays desired humidity level when increasing or decreasing desired level, then reverts to current humidity level after 10 seconds.

Operating the Control Panel

Power

Use the Power button to turn the portable dehumidifier on and off. By default, when you first use the power button, the unit will begin to operate in normal fan speed mode.

Auto-Shut Off: The unit will shut off when the set humidity has been reached, or when the water bucket is full, has been removed, or is not in its proper position.

Timer

The timer mode allows for continuous operation for a user defined set number of hours.

To operate the unit in timer mode:

1. Make sure the power cord is plugged into a power outlet.
2. Press the Power button.
3. Press the Timer button to activate the timer mode. The Timer Mode indicator located above the Timer button will light up green.
4. Press the Increase and Decrease buttons to set the desired number of hours for the dehumidifier to run. The timer can be set in increments of 1 hour up to 24 hours. The timer setting display will flash for approximately 10 seconds before reverting back to displaying the current temperature.
5. To cancel or turn off the timer setting, adjust the increments by using the Increase and Decrease buttons until '0' hours is shown on the display.

Fan Speeds

The dehumidifier has two fan speeds. Use the high fan speed for maximum moisture removal. Use the normal fan speed for quieter operation.

Select the fan speed by pressing the Fan button until the desired mode is illuminated.

Setting the Humidity Level

The desired humidity level can be set within a range of 30% Relative Humidity (RH) to 90% RH in 5% increments.

To set the desired humidity level percentage:

1. Make sure the power cord is plugged into a power outlet.
2. Press the Power button.
3. Press the Increase and Decrease buttons to set the desired humidity level. After approximately 10 seconds, the LED display will revert to the actual room humidity level with $\pm 5\%$ accuracy. For drier air use the Decrease button.



Note: Relative Humidity (RH) is the ratio of the actual water content of the air at a given temperature to the potential water content at that same temperature.

LED Display

There are 2 LED displays located on the control panel of this unit.

Temperature and Timer Display

When operating normally, this will display the current temperature in the room where the dehumidifier is located. When adjusting the timer setting, this will display the hours remaining for the timer.

Humidity Level Display

When operating normally, this will display the current relative humidity in the room where the dehumidifier is located. When adjusting the desired humidity setting, this will display the humidity level you set.

Error Codes

In addition to showing the humidity, the display screens may show the following error codes:

E1 -Temperature sensor error

E2 – Defrost sensor error

E3- Humidity sensor error

For E1, E2, and E3 error codes, power the unit off, and then unplug the unit for 15 minutes. Plug the unit in and power it on. If the issue persists, please contact customer service.

LO- Temperature too low error

This means the current room temperature is below 32°F. Make sure the ambient temperature is suitable for the unit (41°F-95°F). If the ambient temperature is suitable, please contact customer service.

HI-Temperature too high error

This means the current room temperature is above 122°F. Make sure the ambient temperature is suitable for the unit (41°F-95°F). If the ambient temperature is suitable, please contact customer service.

Water Full Light

The Water Full Light will illuminate when the bucket is ready to be emptied. The light also turns on when the bucket is not installed at all or is not installed correctly. Once the water is drained, and the bucket is properly installed, the light will no longer illuminate and the unit will operate normally.

Additional Notes About the Dehumidifier's Behavior

- Once the unit reaches the desired humidity level, the power button will remain lit while the compressor and fan shut off.
- When turning the unit off and back on in a normal manner the dehumidifier will retain its last target humidity settings except in the event of a power interruption (i.e. power outage or if unit is unplugged).
- If the unit is turned on when the room's relative humidity is lower than the desired humidity level, the unit will run for a short period of time and then the compressor and fan will shut off.

Draining the Unit

There are 3 different ways in which this dehumidifier can be drained: pump drain, manual drain, and continuous gravity drain. Please review the below descriptions and instructions for each method to determine which is best for your specific setup.

Pump Drain

This dehumidifier comes with the built-in pump that will engage automatically to drain water into a floor drain or other suitable drainage port. To setup the dehumidifier to utilize the built-in pump please follow the instructions below.



Note: The pump will not be activated if the water bucket is full or not installed properly. Please empty the water bucket and re-install it properly before using the pump drain feature.

1. Locate the pump drain hose and insert firmly into pump drain outlet on the lower left side of the back of the unit.
2. The drain hose will click into place when attached properly.
3. Place the other end of the drain hose in a floor drain or other suitable drainage port.
4. Operate the unit in a normal manner.
5. To remove pump drain line, (1) press the release button located directly above the pump outlet and (2) pull the line straight out of the unit.

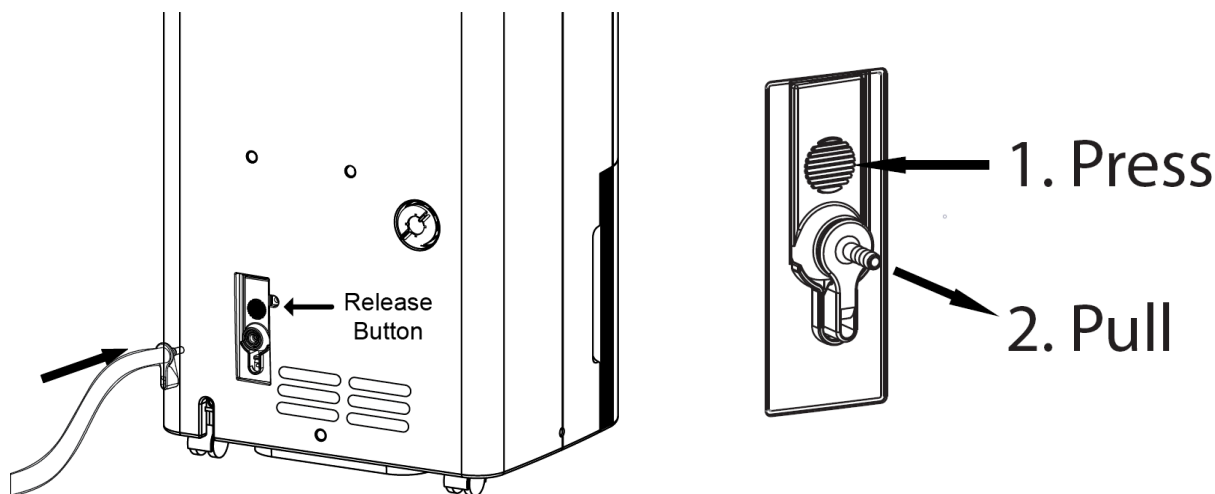

Note: The pump is capable of pumping water up to 16ft vertically or horizontally.



Note: If the pump drain hose has not been connected properly, the unit will not activate the pump feature. A sensor is located at the pump drain hose connection to detect if the hose has been properly connected. An audible 'click' will be heard when the pump drain hose is inserted properly. Once connected properly, the dehumidifier will automatically switch to using the drain pump.

Manual Drain

The dehumidifier can be drained manually using the water bucket. When the bucket is full, the unit will automatically stop running, and the Bucket Full light will illuminate. Follow the below steps to remove the bucket and dump the water.

1. Slowly and carefully pull the bucket out by the handles and lift upward to remove it.
2. Use both hands to carefully empty the water bucket.
3. Reinstall the bucket. Please note that this unit is designed to not operate if the water bucket has not been installed properly.

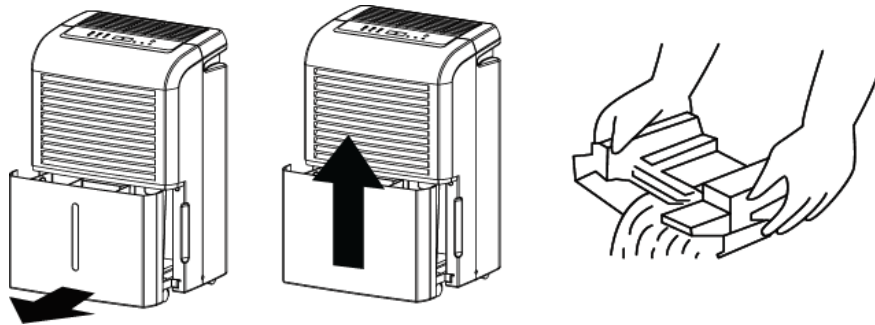

Warning: The water produced by the dehumidifier is not potable or suitable for drinking. **Do not** drink the water drained from the unit as it contains contaminants that could make you sick.

Additional notes when emptying the water bucket:

- Do not place the bucket on the floor as its bottom is uneven and it will not stand upright on its own.
- There is a carrying handle located inside the water bucket that can be used as needed for carrying the water bucket.

Continuous Gravity Drain

The dehumidifier can be drained continuously to a suitable floor drain by using the gravity drain port. In order to utilize the continuous gravity drain you will need to supply a suitable drain hose. You may use a standard garden hose with a $\frac{3}{4}$ " connector fitting.



Note: A continuous gravity drain hose is not included. It must be provided separately. A dehumidifier drain hose or standard garden hose with a $\frac{3}{4}$ " fitting is required. As with all hose attachments, ensure that a rubber gasket is installed in the hose fitting in order to prevent leaks.

1. Locate the gravity drain hose port found on the back of the unit (located on the middle, right hand side).
2. Unscrew the drain cover by turning it counter clockwise, and remove the rubber stopper.
3. Screw the drain hose onto the threaded portion of the drain outlet and tighten it firmly.
4. Place the other end of the drain hose in a floor drain or other suitable drainage port. The drain must be located below the level of the drain outlet on the back of the unit to allow for proper gravity drainage.

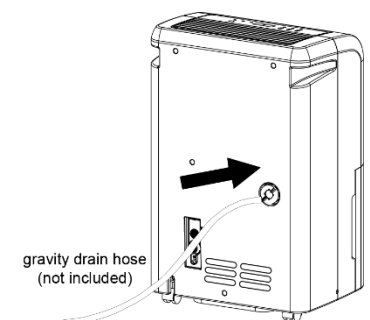

Maintenance

Clean the dehumidifier and pre-filter regularly to maintain maximum performance and efficiency and to prolong the unit's life. Be sure to always unplug the dehumidifier from the power outlet before cleaning.

Cleaning the Unit

Use a soft dry cloth to wipe the body clean. If necessary, use lukewarm water to dampen a cloth to clean the unit. Use a soft bristle brush and vacuum cleaner to clean between the air intake and exhaust vents.

Never use abrasive chemicals, volatile substances, gasoline, detergents, chemically treated cloths, or other cleaning solvents that may damage the cabinet exterior.

Never spray water directly on the unit.

Cleaning the Pre-filter

Clean the pre-filter periodically to prolong the unit's life, and keep the unit running efficiently. Lint, dust, and dirt can clog the unit and reduce its performance and effectiveness. If the unit is used in a dusty environment you may need to clean the pre-filter on a weekly basis.



Important: On a regular basis it is required that the pre-filter be inspected for buildup of lint, dust, and other materials. A clogged pre-filter can restrict proper airflow and cause undue strain on the mechanical components of your dehumidifier resulting in reduced performance and shorter product lifespan.

To clean the pre-filter, follow the steps below:

1. Power off the unit. Remove the water bucket and then remove the pre-filter as shown below.

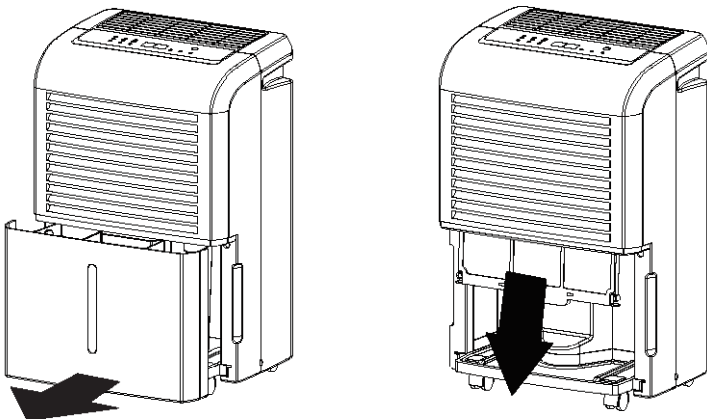

2. Use a vacuum cleaner or tap the pre-filter lightly to remove loose dust and dirt, then rinse it thoroughly under lukewarm running water (below 104°F). You may use a mild soap and water solution if needed. Allow the pre-filter to air dry in a cool and shaded place. Dry the pre-filter thoroughly before reinstalling it.
3. Reinsert the pre-filter.



Note: Do not put the filter in a dishwasher.



Warning: Never operate the unit without the pre-filter.

Cleaning the Water Bucket

Wash the water bucket frequently to prevent the growth of bacteria, mildew, and mold.

To clean the water bucket, follow the steps below:

1. Remove the water bucket from the unit.
2. Wash the bucket with clean water and a mild detergent. Rinse the bucket thoroughly.
3. Install the water bucket.



Note: Do not put the water bucket in a dishwasher.

Preparation for Storage

If you are not going to be using the unit for an extended period of time, follow the instructions below before storing your unit:

1. Turn the unit off, unplug it, and wait 24 hours before emptying the water bucket to allow for excess moisture to drain into the bucket.
2. Drain all water from the water tank.
3. Clean the air filter, water tank, and unit.
4. Unplug and carefully wind the power cord.
5. Cover the unit with a plastic bag.
6. Store the unit in an upright position in a dry, well-ventilated place.

Auto-Defrost

When the unit is operated in temperatures below 54°F the surface of the evaporator may accumulate a layer of frost which will reduce the efficiency and effectiveness of the dehumidifier. When this occurs, the unit will automatically activate its auto-defrost feature. The time required to complete the auto-defrost cycle varies and is dependent on the ambient temperature and relative humidity of the operating environment. The auto-defrost indicator located on the control panel will light up when the auto-defrost feature is running.



Note: Do not operate this dehumidifier in temperatures below 41°F.

Energy Saving Guide

Read and follow the guide below to get the best performance and efficiency from your portable dehumidifier:

- Do not cover the air outlet (exhaust) while in use.
- Do not place the unit in front of curtains or drapes to ensure they do not obstruct the air intake.
- Keep curtains, blinds, or drapes closed during the sunniest part of the day.
- Close all windows and doors.
- Indoor relative humidity should ideally be kept between 35 and 60 percent depending on the ambient temperature.
- Make sure the unit is on a level surface.
- To prolong the compressor's life, please wait at least 3 minutes before turning the unit back on after shutting it off.
- Inspect and keep the pre-filter clean by cleaning it regularly.
- Perform routine maintenance.

Troubleshooting

Follow the troubleshooting guide below to resolve common issues.

Issue	Possible Cause	Solution
My dehumidifier does not dry the air.	There is insufficient time to dry.	Run the unit for a longer period of time.
	The air intake or exhaust vents are blocked.	Make sure there are no towels, curtains, or furniture blocking the front or back of the unit.
	The humidity control may not be set low enough.	Lower the desired humidity setting.
	There are open windows or doors.	Close all windows and doors.
	The room temperature is too low (below 41°F).	Increase the room temperature.
	There is a kerosene heater or other device giving off water vapor in the room.	Remove any device producing water vapor.
Frost appears on the coils.	This is normal behavior.	The dehumidifier has an auto-defrost feature.
My dehumidifier is not functioning at all.	The unit is not receiving power.	Make sure the unit is plugged in.
	There is insufficient power.	Move the unit to another outlet. Check your circuit breaker. (Refer to the rating label on the back of the unit to determine the Amperage draw.)
	The water bucket is full.	Drain the water bucket and restart the unit.
	The water bucket is not in the proper position.	Remove the bucket and reinsert it.
	The control panel is not functioning.	If no indicator lights turn on, contact customer service.
My dehumidifier is making a loud noise.	The air filter is clogged.	Clean the air filter.
	A foreign object has jammed the fan.	Shut off the unit and remove the object from the fan.
	The floor below the unit is uneven.	Move the unit to a level surface.
My dehumidifier is making a continuous metallic knocking or pinging sound.	The unit may have been shipped on its side.	Shut off the unit. Let the unit sit on a level surface for at least 24 hours and restart.
	The compressor is damaged.	Contact customer service.

Issue	Possible Cause	Solution
My dehumidifier is leaking.	A drain hose has been attached and is loose.	Secure the drain hose. Route your drain hose to a floor drain or other suitable drainage port.
	The water bucket is cracked.	Contact customer service.
My dehumidifier runs for a little while and then it trips the power cord or the circuit breaker.	The dehumidifier may be plugged into an outlet that cannot supply the correct amount of electrical current.	Contact an electrician if the unit works in a different room or on a different circuit.
The control panel lights blink randomly.	The unit may have a faulty control panel.	Restart the unit, and if the issue persists, contact customer service.
The unit has an "E1" Error.	This is a temperature sensor error.	Restart the unit, and if the issue persists, contact customer service.
The unit has an "E2" Error.	This is a defrost sensor error.	Restart the unit, and if the issue persists, contact customer service.
The unit has an "E3" Error.	This is a humidity sensor error.	Restart the unit, and if the issue persists, contact customer service.
The unit has a "LO" Error.	The current room temperature is below 32°F.	Make sure the ambient temperature is suitable for the unit (41°F – 95°F). If the ambient temperature is suitable, please contact customer service.
The unit has a "HI" error.	The current room temperature is above 122°F.	Make sure the ambient temperature is suitable for the unit (41°F – 95°F). If the ambient temperature is suitable, please contact customer service.

Specifications

Description of product	Portable Dehumidifier	Portable Dehumidifier
Model	DEP501WP	DEP701WP
Voltage/Frequency	AC 115V~60Hz	AC 115V~60Hz
Power Consumption	540 W	862 W
Operating Current	4.7 A	7.5 A
Water Bucket Capacity	8 Liters / 2.11 Gallons	8 Liters / 2.11 Gallons
Dehumidifying Capacity at 80°F RH 60%	50 pints / day	70 pints / day
Refrigerant	R410A	R410A
Dimensions W x D x H	15.25" x 11.13" x 23.75"	15.25" x 11.13" x 23.75"
Weight	39 lbs.	45 lbs.

EdgeStar Limited Warranty

One (1) Year Parts & Ninety (90) Days Labor

This product is warranted by EdgeStar to be free from defective workmanship and materials, subject to any conditions set forth as follows:

WHAT IS COVERED:

LABOR: For a period of NINETY (90) DAYS from the date of original purchase, labor will be performed free of charge at an authorized EdgeStar repair facility. At its option, EdgeStar will repair the product with new or remanufactured parts, or exchange the defective product with a new, refurbished, or remanufactured product. If a product is replaced, it will carry the remaining warranty of the original product. After the ninety (90) day period, EdgeStar will no longer be responsible for labor charges incurred. All defective products and parts covered by this warranty will be repaired or replaced on a mail-in basis to an EdgeStar authorized repair facility.

PARTS: For a period of ONE (1) YEAR from the date of original purchase, EdgeStar will supply new, rebuilt, or refurbished parts free of charge. EdgeStar may request a defective part be returned in exchange for the replacement part. All replacement parts or products will be new, remanufactured, or refurbished. All products and parts replaced by EdgeStar under warranty service become the property of EdgeStar.

This warranty applies to the original purchaser only, and only covers defects in workmanship experienced during operation of the product under normal service, maintenance, and usage conditions. This warranty applies to the purchase and use of this product in residential settings within the contiguous United States of America.

WHAT IS NOT COVERED:

The following limitations apply to the coverage of this warranty. This warranty does not cover:

- Labor charges for installation, setup or training to use the product.
- Shipping damage, and any damage caused by improper packaging for shipment to an authorized service center, and any damaged caused by improper voltage or any other misuse, including abnormal service, handling, or usage.
- Cosmetic damage such as scratches and dents.
- Normal wear and tear on parts or replacement of parts designed to be replaced, e.g. filters, cartridges, batteries.
- Service trips to deliver, pick-up, or repair, install the product, or to instruct in proper usage of the product.
- Damages or operating problems resulting from misuse, abuse, operation outside environmental specifications, uses contrary to instructions provided in the owner's manual, accidents, acts of God, vermin, fire, flood, improper installation, unauthorized service, maintenance negligence, unauthorized installation or modification, or rental or commercial use.
- Labor, service transportation, and shipping charges incurred 91 days or more after the date of original purchase.
- The use of EdgeStar products in commercial or rental settings.
- Optional accessories, attachments, and appearance items.
- Products that have been modified to perform outside of specifications without the prior written permission of EdgeStar.
- Products lost in shipment, or theft.
- Products sold AS IS or from an unauthorized reseller.
- Products that have had their serial numbers removed or defaced. Products with serial numbers that have been invalidated.
- Damage to personal property from use of product.
- Replacement of repair of household fuses, circuit breakers, wiring, or plumbing.

OBTAINING WARRANTY SERVICE:

If you believe your product is defective, contact EdgeStar Customer Support for troubleshooting assistance and warranty service at www.edgestar.com or 1-866-319-5473. Before contacting EdgeStar, have your serial number and proof of purchase available. Once an EdgeStar authorized representative has confirmed that your product is defective and eligible for warranty service, the product must be returned to an EdgeStar repair facility. The purchaser is solely responsible for prepaying all shipping related costs to and from the repair facility. EdgeStar is not responsible for damage resulting from shipper mishandling or improper packaging. Do not return a defective product to the place of purchase. Products received without a return authorization number will be refused.

THIS WARRANTY IS IN LIEU OF ANY OTHER WARRANTY, EXPRESSED OR IMPLIED, INCLUDING WITHOUT LIMITATION, ANY WARRANTY OF MERCHANTABILITY OR FITNESS FOR A PARTICULAR PURPOSE. TO THE EXTENT ANY IMPLIED WARRANTY IS REQUIRED BY LAW, IT IS LIMITED IN DURATION TO THE EXPRESS WARRANTY PERIOD ABOVE. NEITHER THE MANUFACTURER NOR ITS DISTRIBUTORS SHALL BE LIABLE FOR ANY INCIDENTAL, CONSEQUENTIAL, INDIRECT, SPECIAL, OR PUNITIVE DAMAGES OF ANY NATURE, INCLUDING WITHOUT LIMITATION, LOST REVENUES OR PROFITS, OR ANY OTHER DAMAGE WHETHER BASED IN CONTRACT, TORT, OR OTHERWISE. IN NO EVENT AND UNDER NO CIRCUMSTANCE OF ANY TYPE OR KIND SHALL THE SELLER, MANUFACTURER AND/OR DISTRIBUTOR BE LIABLE FOR ANY REASON, UNDER ANY THEORY, FOR MORE THAN THE BASIC COST OF THE PRODUCT TO THE PURCHASER OR END USER. SOME STATES DO NOT ALLOW THE EXCLUSION OF INCIDENTAL OR CONSEQUENTIAL DAMAGES, SO THE ABOVE EXCLUSION MAY NOT APPLY TO YOU. THIS WARRANTY GIVES YOU SPECIFIC LEGAL RIGHTS. YOU MAY HAVE OTHER RIGHTS THAT VARY FROM STATE TO STATE.