



DECOLAV[®]

424 SW 12th Avenue
Deerfield Beach, Florida 33442
Call: 561-274-2110 • Fax: 954-601-0881
www.decolav.com



DECOLAV®

9020 SERIES

Mounting Ring

ROUGHING-IN DIMENSIONS - INSTALLATION INSTRUCTIONS

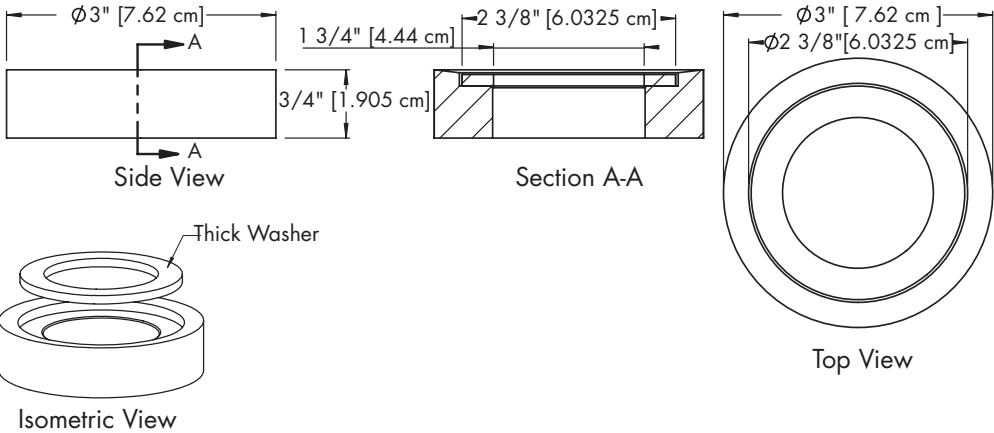

- Prepare Countertop by drilling a $1\ 3/4''$ (4.445 cm) diameter drain hole at desired location.
- Place **Mounting Ring** above Countertop's drain hole.
- Place **Thick Washer** into top groove of Mounting Ring.
- Place Lavatory on **Mounting Ring**.
- Secure Lavatory to **Mounting Ring** by installing Drain according to manufacturer's provided installation instructions.
- **NOTE: DO NOT OVERTIGHTEN DRAIN!**
- Install waste system.
- Check for leakage.

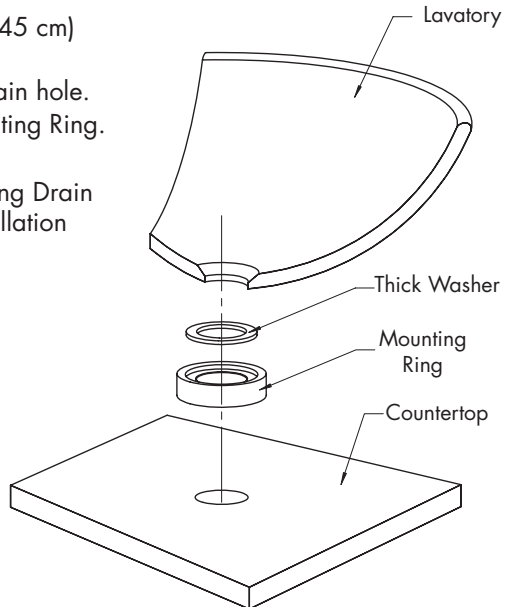



DECOLAV®

SERIE 9020

Anillo de montaje

MEDIDA APROXIMADA - INSTRUCCIONES DE INSTALACIÓN

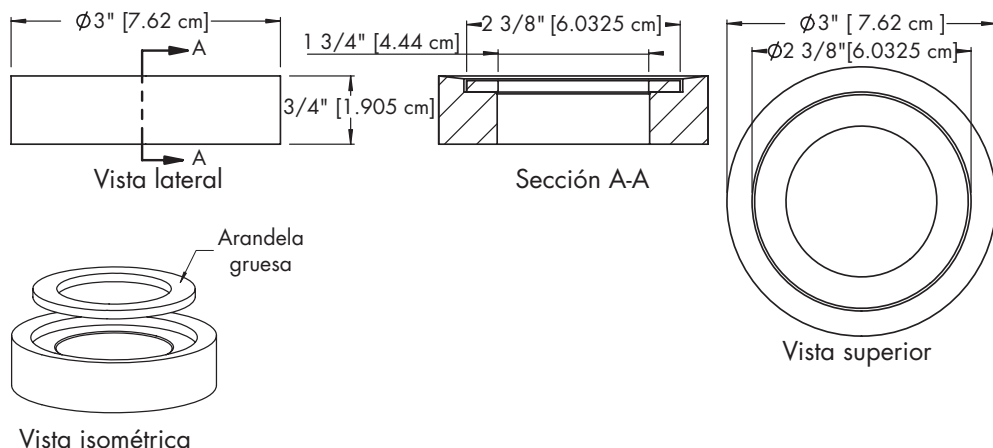

- Prepare el mostrador haciendo un agujero de 1 3/4" (4.445 cm) de diámetro para el desagüe en el lugar que desee.
- Coloque el **anillo de montaje** sobre el agujero del desagüe del mostrador.
- Coloque la **arandela gruesa** en la ranura superior del **anillo de montaje**.
- Coloque el lavamanos en el **anillo de montaje**.
- Fije el lavamanos en el **anillo de montaje** instalando el desagüe según la instrucciones de instalación del fabricante.
- **NOTA: NO AJUSTE DEMASIADO EL DESAGÜE**
- Instale el sistema de desagüe.
- Compruebe que no haya fugas.

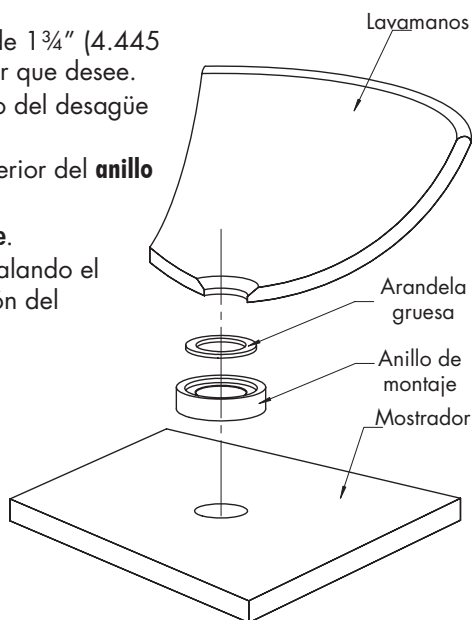



DECOLAV®

SÉRIE 9020

Anneau de montage

DIMENSIONS DE RACCORDEMENT - INSTRUCTIONS D'INSTALLATION

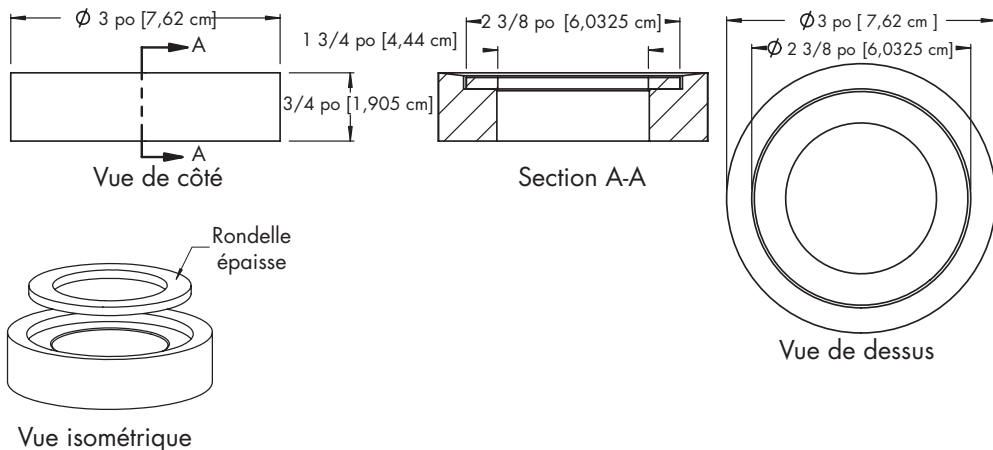

- Préparez le comptoir en perçant un trou d'évacuation d'un diamètre de 1 3/4 po (4,445 cm) à l'emplacement souhaité.
- Placez **l'anneau de montage** au-dessus du trou pour le drain percé dans le comptoir.
- Placez la **rondelle épaisse** dans la rainure supérieure de **l'anneau de montage**.
- Placez le lavabo sur **l'anneau de montage**.
- Fixez fermement le lavabo sur **l'anneau de montage** en installant le drain selon les directives d'installation du fabricant.
- **REMARQUE : NE SERREZ PAS LE DRAIN DE FAÇON EXCESSIVE !**
- Installez le circuit d'évacuation.
- Vérifiez qu'il n'y a pas de fuite.

