



# Elizabethan Classics

## Specification for ECRT54RM

Hole	Diameter
Drain	2" +/- 1/8
Over Flow	2-1/4" +/- 3/16
Faucet	1-3/8" +/- 1/8
Capacity	35 US Gallon
Weight of Tub	209.44 lbs
Weight of Tub filled with water	502.04 lbs

**Top View**

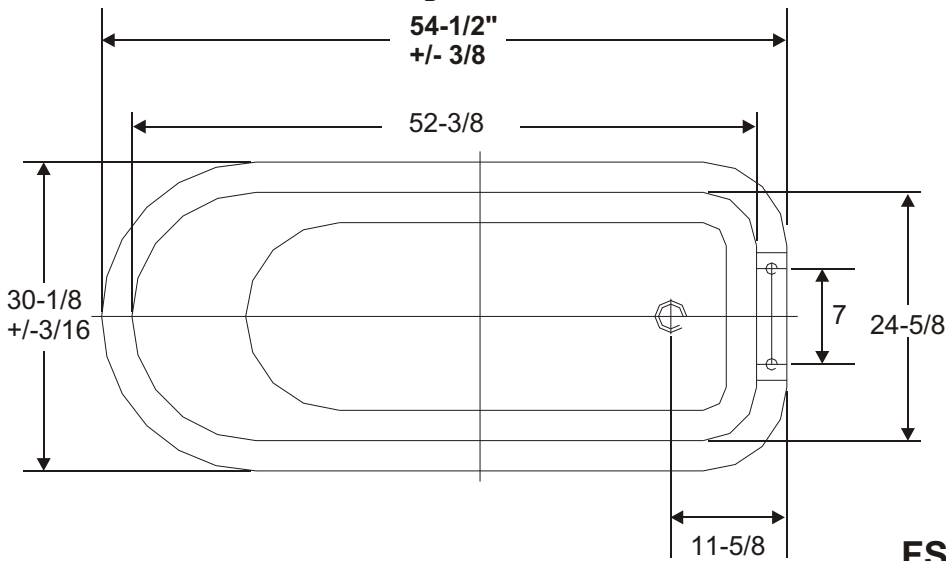

**End View**

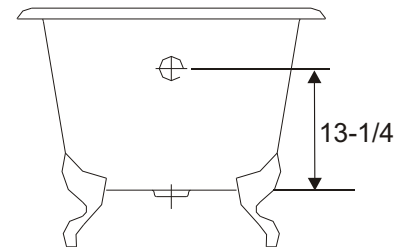

**Side View**

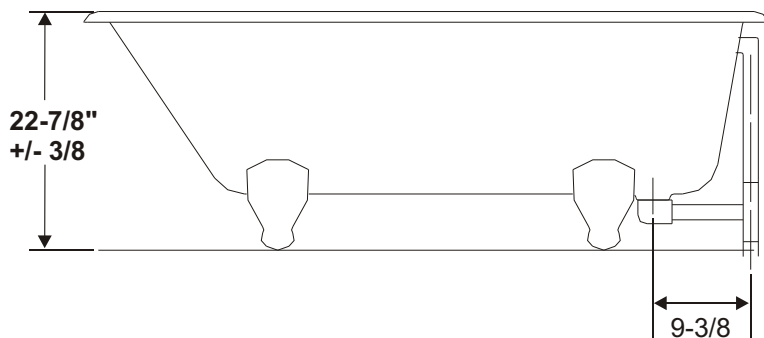

**FSMR Feet Placement Diagram**

