

Installation Instructions / Warranty

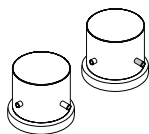

Axor Starck
10480XX1

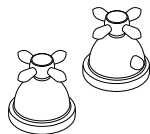

Axor Carlton
17480XX1

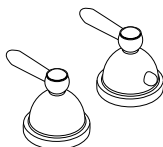

Axor Carlton
17482XX1

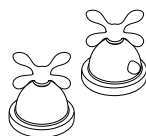

Axor Phoenix
17580XX1

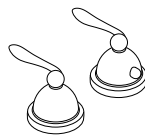

Axor Phoenix
17582XX1

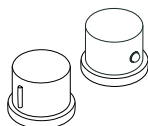

Axor Steel
35480801

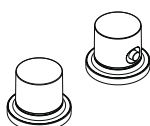

Axor Massaud
18480XX1

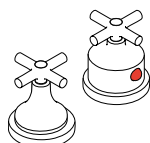

Axor Terrano
37480XX1

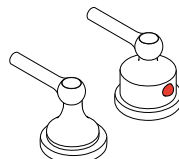

Axor Terrano
37482XX1

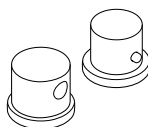

Axor Uno
38480XX1

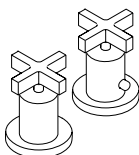

Axor Citterio
39480XX1

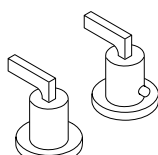

Axor Citterio
39482XX1

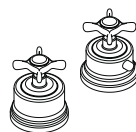

Axor Montreux
16480XX1

Trim Kit for 2-Handle Roman Tub Set

hangrohe

Axor Trim Kit for 2-Handle Roman Tub Set

Axor Starck
10480XX1

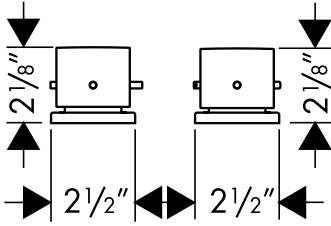

Axor Carlton
17480XX1

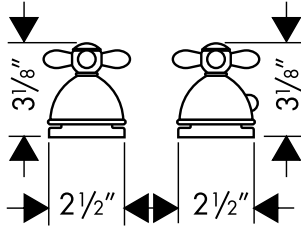

Axor Carlton
17482XX1

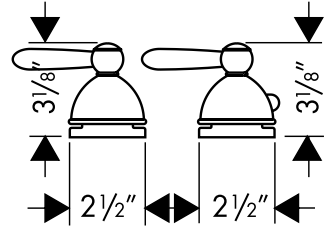

Axor Phoenix
17580XX1

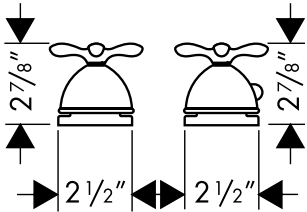

Axor Phoenix
17582XX1

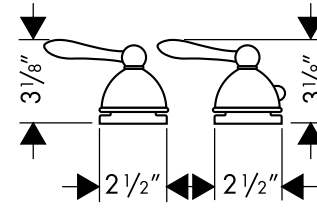

Axor Steel
35480801

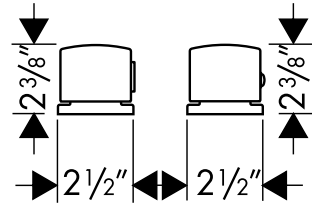

Axor Massaud
18480XX1

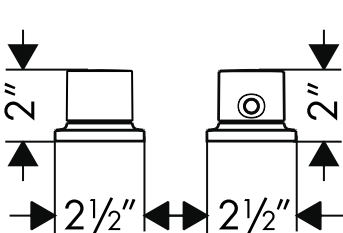

Axor Terrano
37480XX1

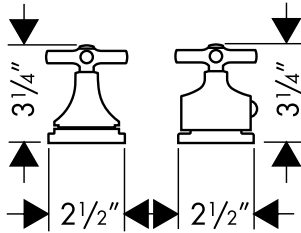

Axor Terrano
37482XX1

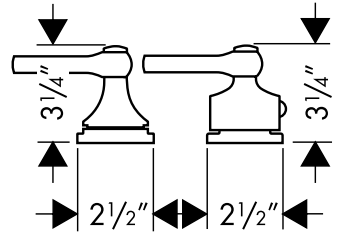

Axor Uno
38480XX1

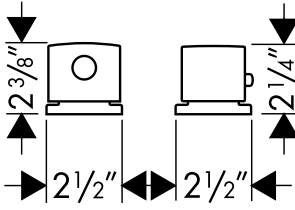

Axor Citterio
39480XX1

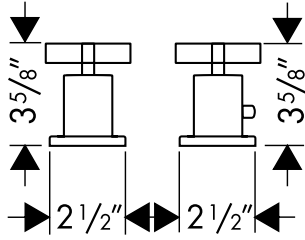

Axor Citterio
39482XX1

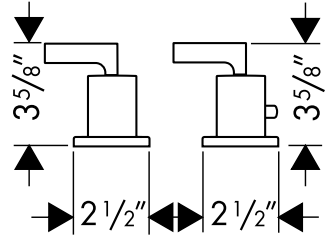

Axor Montreux
16480XX1

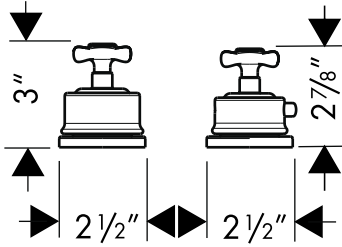

Installation

This trim kit is for use with rough-in 13550181.

The surface material must be installed and sealed prior to installation of this trim kit.

Turn the water off at the main (1).

Massaud only:

Remove the stem extension, stem extension screw, and safety set (2).

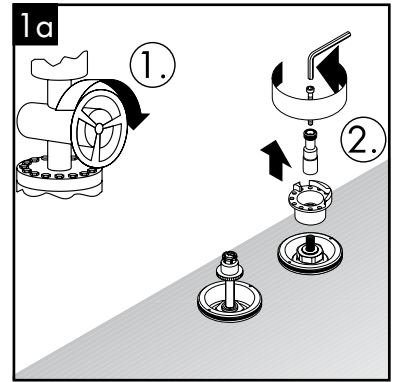

Install the new sleeve and stem extension

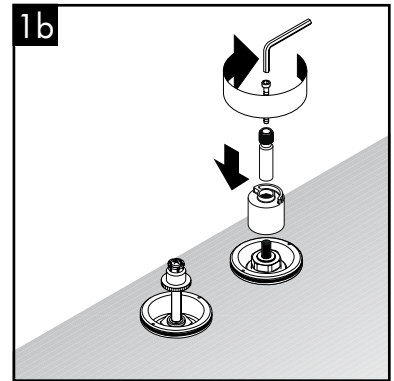

Terrano only:

Remove the snap connector. Install the flanges. Reinstall the snap connector.

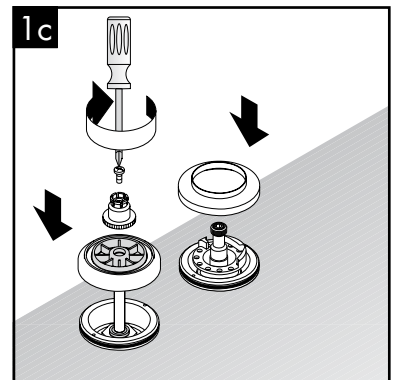

Montreux only:

Remove the snap connector. Install the flanges.

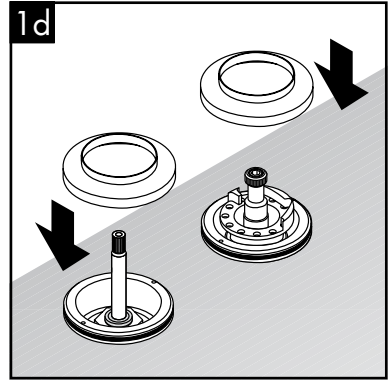

All models:

Install the flanges.

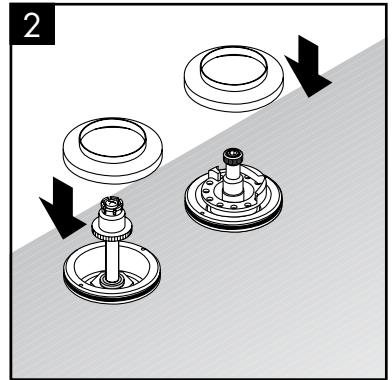

Locate the decal sheet. Pull the backing strips from the 0, 1, and 2 decals.

Place the decal sheet around the diverter (1). Peel it off so that the 0, 1, and 2 decals are left behind (2).

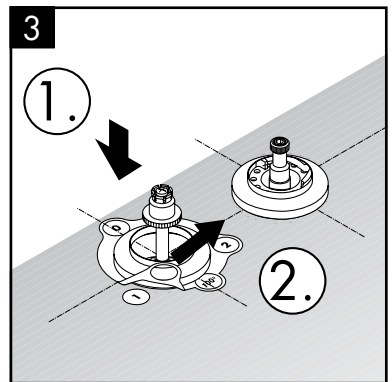
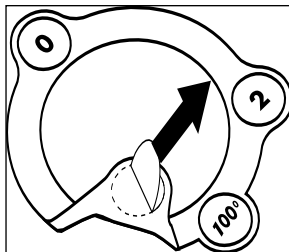

Place the decal sheet around the thermostatic mixer. Peel it off so that the 100° decal is left behind.

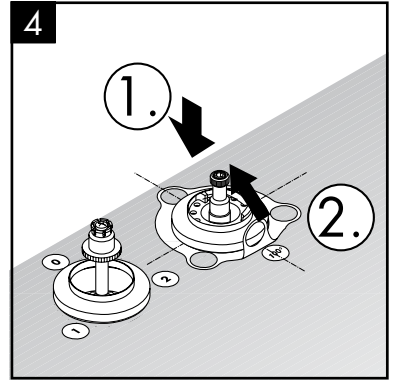

Turn the water on at the main (1).

If water comes through the spout, position the diverter handle so that the indicator is next to decal 1.

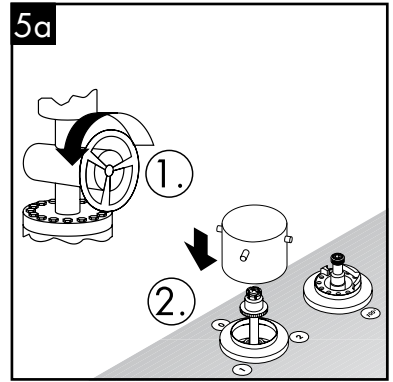
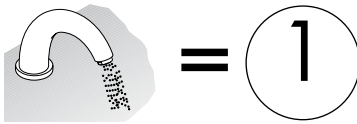

If water comes through the handshower, position the diverter handle so that the indicator is next to decal 2.

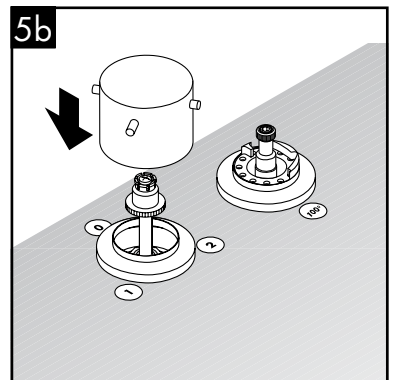
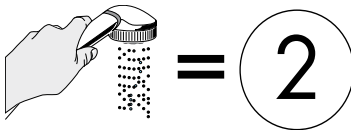

If the water is off, position the diverter handle so that the indicator is next to decal 0.

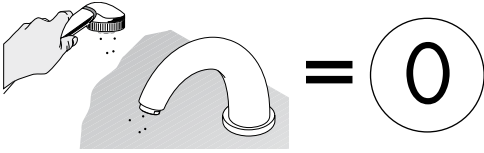

All models except Montreux:

Push the handle firmly into place over the snap connector.

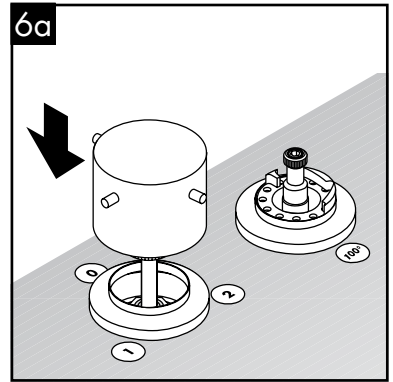
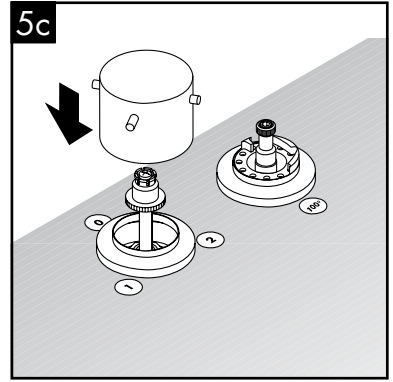

Montreux only:

Tighten the handle screw with a 3 mm Allen wrench.
Install the screw cover.

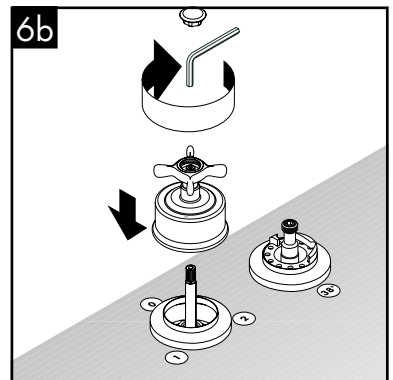

All models:

Place the thermostatic mixer handle on the stem.

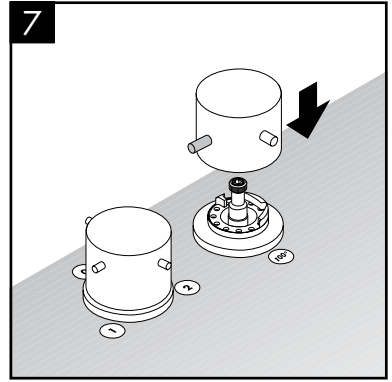

Turn the thermostatic mixer handle until the water coming out measures 100°F on a thermometer.

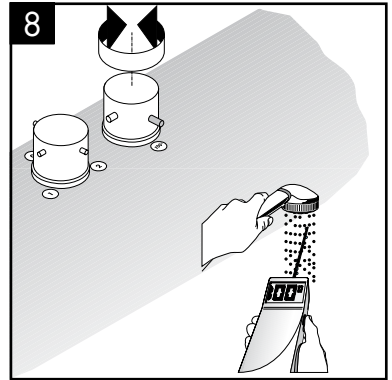

Remove the handle.

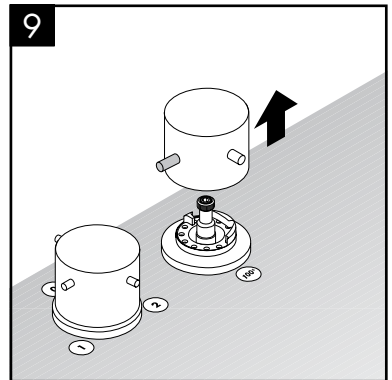

Reposition the thermostatic mixer handle so that the safety stop override button is next to the 100° decal. Tighten the set screw.

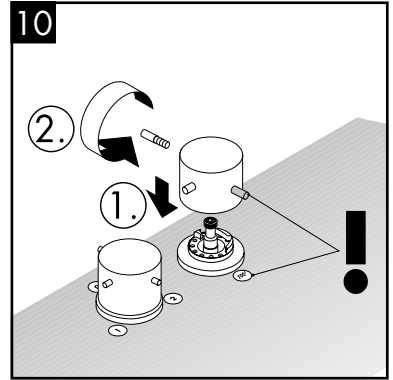

User Instructions

Turn the thermostatic mixer handle clockwise to make the water cooler, counter-clockwise to make it warmer. The handle will stop when the temperature is 100°F. If water hotter than 100°F is desired, press the safety stop override button, and continue turning the handle counter-clockwise.

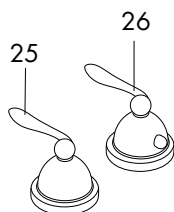
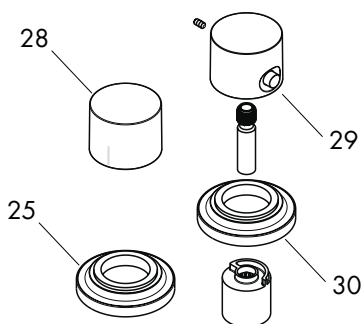
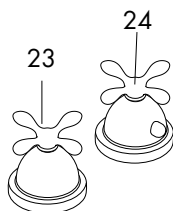
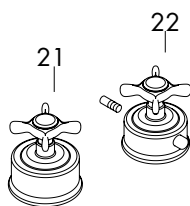
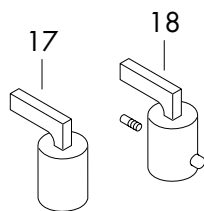
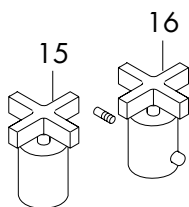
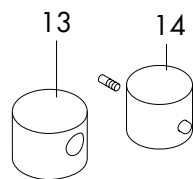
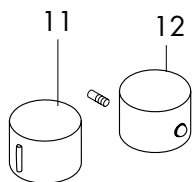
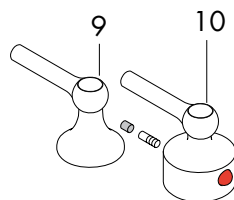
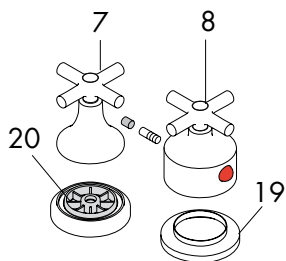
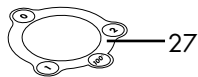
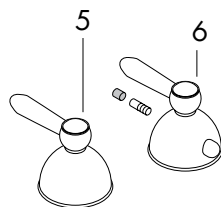
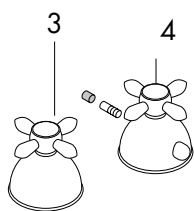
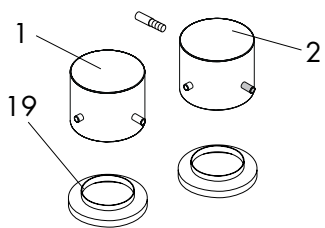

Replacement Parts

1	handle Starck	10993XX0	21	handle, Montreux	16593XX0
2	thermostat handle Starck	10996XX1	22	thermostat handle, Montreux	16596XX1
3	handle Carlton cross	17298XX0	23	handle, Phoenix cross	96792XX1
4	thermostat handle Carlton cross	17394XX1	24	thermostat handle, Phoenix	96791XX1
5	handle Carlton lever	17993XX0	25	handle, Phoenix lever	96632XX1
6	thermostat handle Carlton lever	17395XX1	26	thermostat handle, Phoenix	96631XX1
7	handle Terrano cross	37995XX0	27	decal sheet	97791001
8	thermostat handle Terrano cross	37393XX1	28	Massaud handle	18894000
9	handle Terrano lever	37993XX0	29	thermostat handle, Massaud	18995001
10	thermostat handle Terrano lever	37394XX1	30	Massaud flange	98837000
11	handle Steel	35993800			
12	thermostat handle Steel	35392801	XX	= Colors	
13	handle Uno	38993XX0	00	chrome	
14	thermostat handle Uno	38392XX1	62	oil rub bronze	
15	handle Citterio cross	39392XX0	80	Steel®	
16	thermostat handle Citterio cross	39393XX1	81	Satinox®	
17	handle Citterio lever	39394XX0	82	brushed nickel	
18	thermostat handle Citterio lever	39395XX1	83	polished nickel	
19	flange	21828XX0			
20	flange	96640XX0			

Cleaning Recommendation for Hansgrohe Products

Modern faucetry and shower products utilize a combination of materials to comply with the needs of the market with regard to design and functionality.

To avoid damage, it is necessary to use some caution when cleaning. Damage caused by improper treatment is not covered under the Hansgrohe warranty.

Cleaning Materials for Faucets and Showers

- To remove lime scale, use only products made specifically for that purpose. Always follow the manufacturer's instructions when using.
- Do not use cleaners that contain hydrochloric, formic, acetic, or phosphoric acids, as these will cause considerable damage to finishes and to plastic components.
- Never mix cleaning materials.
- Never use cleaners containing abrasives. Do not use abrasive cleaning cloths, pads, or sponges.

Cleaning Procedures

- Clean your faucets and shower products as and when required. Regular cleaning will prevent scale buildup and water spotting.
- Follow the label instructions. Do not allow any cleaner to remain on the product for longer than necessary.
- When using spray cleaners, spray first onto a sponge or cloth – do not spray directly onto the product.
- After cleaning, rinse thoroughly with clear water to remove any cleaner residue.

Important

- Soap and shampoo residue can also cause damage to the product. Rinse well with clean water after use.
- If the surface is already damaged, harsh cleaning materials will cause further damage.

Limited Lifetime Consumer Warranty

This product has been manufactured and tested to the highest quality standards by Hansgrohe, Inc. ("Hansgrohe"). This warranty is limited to Hansgrohe products which are purchased by a consumer in the United States after March 1, 1996, and installed in either the United States or Canada.

WHO IS COVERED BY THE WARRANTY

This warranty extends to the original consumer purchaser only.

WHAT IS COVERED BY THE WARRANTY

This warranty covers only your Hansgrohe manufactured product. Hansgrohe warrants this product against defects in material or workmanship as follows: Hansgrohe will repair at no charge for parts only or, at its option, replace any product or part of the product which proves defective because of improper workmanship and/or material, under normal installation, use, service and maintenance. If Hansgrohe is unable to provide a replacement and repair is not practical or cannot be timely made, Hansgrohe may elect to refund the purchase price in exchange for the return of the product.

LENGTH OF WARRANTY

Replacement or repaired parts of products will be covered for the term of this warranty as stated in the following two sentences. If you are a consumer who purchased the product for use primarily for personal, family, or household purposes, this warranty extends for as long as you own the product and the home in which the product is installed. If you purchased the product for use primarily for any other purpose, including, without limitation, a commercial purpose, this warranty extends only (i) for 1 year, with respect to Interaktiv and Retroaktiv products, and (ii) for 5 years, with respect to AXOR, ShowerPower and Pharo products.

THIS WARRANTY DOES NOT COVER, AND HANSGROHE WILL NOT PAY FOR:

- A. Conditions, malfunctions or damage not resulting from defects in material or workmanship.
- B. Conditions, malfunctions or damage resulting from (1) improper installation, improper maintenance, misuse, abuse, negligence, accident or alteration, or (2) the use of abrasive or caustic cleaning agents or "no rinse" cleaning products, or the use of the product in any manner contrary to the product instructions.
- C. Labor or other expenses for the disconnection or return of the product for warranty service, or for installation or reinstallation of the product.
- D. Accessories or related products not manufactured by Hansgrohe.

TO OBTAIN WARRANTY SERVICE

Contact your Hansgrohe retailer, or write to Technical Service at:

Hansgrohe Inc.
1492 Bluegrass Lakes Parkway
Alpharetta GA 30004

Or, call Hansgrohe toll-free at (800) 334-0455.

In requesting warranty service, you will need to provide

1. The sales receipt or other evidence of the date and place of purchase.
2. A description of the problem.
3. Delivery of the product or the defective part, postage prepaid and carefully packed and insured, to Hansgrohe Inc. 1492 Bluegrass Lakes Parkway, Alpharetta, Georgia 30004, Attention: Technical Service, if required by Hansgrohe.

When warranty service is completed, any repaired or replacement product or part will be returned to you postage prepaid.

EXCLUSIONS AND LIMITATIONS

REPAIR OR REPLACEMENT (OR, IN LIMITED CIRCUMSTANCES, REFUND OF THE PURCHASE PRICE) AS PROVIDED UNDER THIS WARRANTY IS THE EXCLUSIVE REMEDY OF THE PURCHASER. HANSGROHE NEITHER ASSUMES NOR AUTHORIZES ANY PERSON TO CREATE FOR IT ANY OBLIGATION OR LIABILITY IN CONNECTION WITH THIS PRODUCT.

HANSGROHE SHALL NOT BE LIABLE TO PURCHASER OR ANY PERSON FOR ANY INCIDENTAL, SPECIAL, OR CONSEQUENTIAL DAMAGES, ARISING OUT OF BREACH OF THIS WARRANTY OR ANY IMPLIED WARRANTY (INCLUDING MERCHANTABILITY).

Some States do not allow the exclusion or limitation of incidental or consequential damages, so the above limitation or exclusion may not apply to you.

This warranty gives you specific legal rights, and you may have other rights which vary from State to State.

You may be required by law to give us a reasonable opportunity to correct or cure any failure to comply before you can bring any action in court against us under the Magnuson-Moss Warranty Act.

PRODUCT INSTRUCTIONS AND QUESTIONS

Upon purchase or prior to installation, please carefully inspect your Hansgrohe product for any damage or visible defect. Prior to installing, always carefully study the enclosed instructions on the proper installation and the care and maintenance of the product. If you have questions at any time about the use, installation, or performance of your Hansgrohe product, or this warranty, please call or write to us at the toll-free number and address printed above.



Hansgrohe, Inc. • 1490 Bluegrass Lakes Parkway • Alpharetta, GA 30004
Tel. 770 360-9880 • Fax 770 360 9887

www.hansgrohe-USA.com