

# Installation Instructions / Warranty

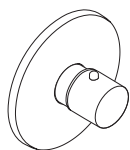

**Uno**  
38475XX1  
38379XX1

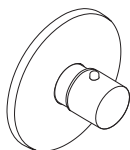

**Steel**  
35375801  
35379801

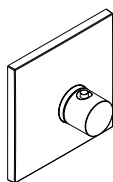

**Massaud**  
18743001  
18747001

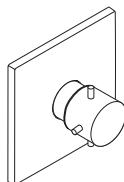

**Starck X**  
10385XX1  
10386XX1

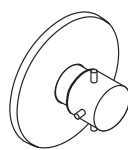

**Starck**  
10375XX1  
10379XX1

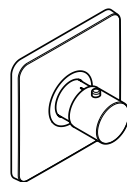

**Citterio M**  
34715XX1  
34716XX1

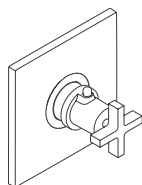

**Citterio**  
39384XX1  
39387XX1

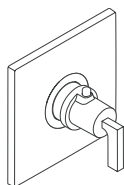

**Citterio**  
39385XX1  
39386XX1

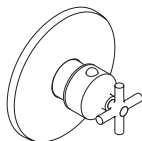

**Terrano**  
37375XX1  
37379XX1

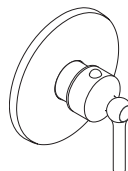

**Terrano**  
37475XX1  
37374XX1



**Montreux**  
16810XX1  
16815XX1



**Montreux**  
16811XX1  
16814XX1

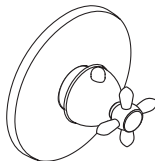

**Carlton**  
17375XX1  
17374XX1

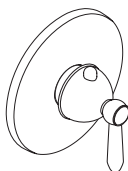

**Carlton**  
17475XX1  
17379XX1



**Phoenix**  
17384XX1  
17387XX1



**Phoenix**  
17385XX1  
17386XX1

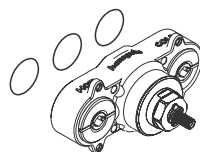

Upgrade Kit  
06800XX3

# AXOR<sup>®</sup>

hansgrohe

## Ecostat / EcoMax Trim Kits

### **Axor Starck**

10375XX1 Ecostat  
10379XX1 EcoMax

### **Axor Starck X**

10385XX1 Ecostat  
10386XX1 EcoMax

### **Axor Citterio - Cross Handle**

39384XX1 Ecostat  
39387XX1 EcoMax

### **Axor Citterio - Lever Handle**

39385XX1 Ecostat  
39386XX1 EcoMax

### **Axor Citterio M**

34715XX1 Ecostat  
34716 EcoMax

### **Axor Massaud**

18743001 Ecostat  
18747001 EcoMax

### **Axor Steel**

35375801 Ecostat  
35379801 EcoMax

### **Axor Uno**

38475XX1 Ecostat  
38379XX1 EcoMax

### **Axor Montreux**

16810XX1 Ecostat  
16815XX1 EcoMax

### **Axor Montreux - Lever Handle**

16811XX1 Ecostat  
16814XX1 EcoMax

### **Axor Terrano - Cross Handle**

37375XX1 Ecostat  
37379XX1 EcoMax

### **Axor Terrano - Lever Handle**

37475XX1 Ecostat  
37374XX1 EcoMax

### **Axor Carlton - Cross Handle**

17475XX1 Ecostat  
17379XX1 EcoMax

### **Axor Carlton - Lever Handle**

17375XX1 Ecostat  
17374XX1 EcoMax

### **Axor Phoenix - Cross Handle**

17384XX1 Ecostat  
17387XX1 EcoMax

### **Axor Phoenix - Lever Handle**

17385XX1 Ecostat  
17386XX1 EcoMax

### **EcoMax Upgrade Kit**

06800XX3

## **Installation Considerations**

- For best results, Hansgrohe recommends that this trim kit be installed by a licensed, professional plumber.
- Prior to the installation of this trim kit, rough valve 15373181 or 15374181 must be installed. The finished wall must be complete.



**The water must be turned off at the main before beginning installation.**

- The Ecostat and EcoMax function blocks incorporate isolation stops and check valves.

These trim kits are compatible with the new style rough, manufactured after 10/2003. Note the more rectangular opening.

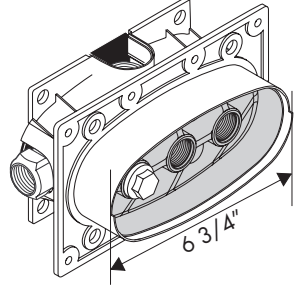
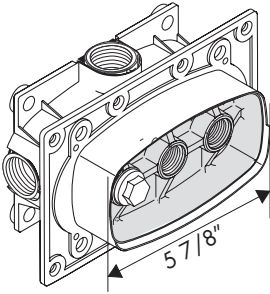

These trim kit are not compatible with the older-style rough, manufactured before 10/2003. The opening is too wide to be covered by the escutcheon.

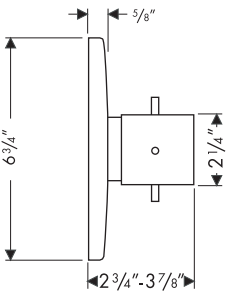

10375XX1  
10379XX1

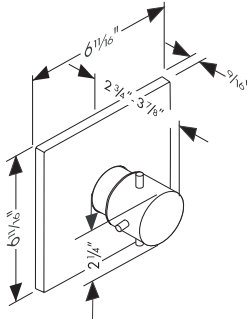

10385XX1  
10386XX1

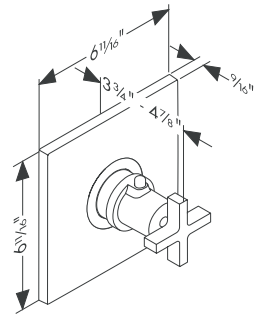

39384XX1  
39387XX1

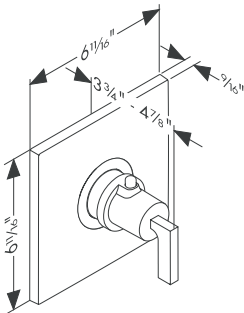

39385XX1  
39386XX1

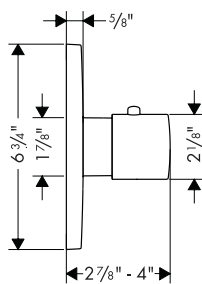

34715XX1  
34716XX1

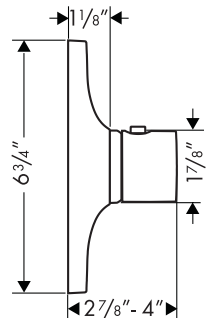

18743001  
18747001

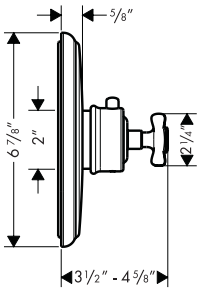

16810XX1  
16815XX1

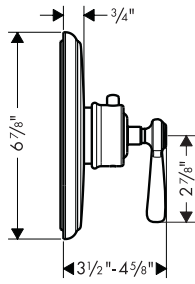

16811XX1  
16814XX1

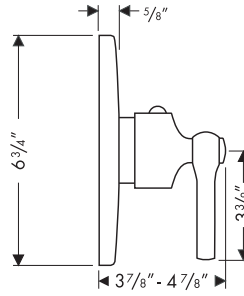

37475XX1  
37374XX1

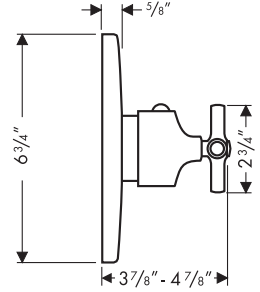

37375XX1  
37379XX1

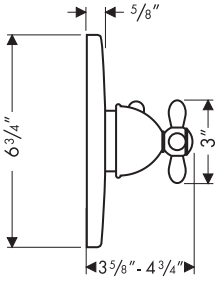

17475XX1  
17379XX1

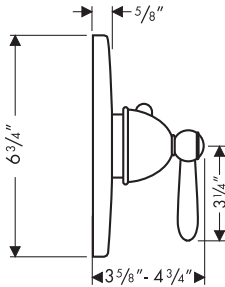

17375XX1  
17374XX1

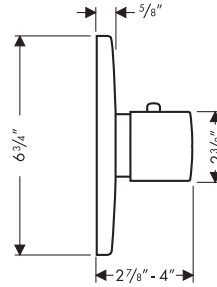

38475801  
38379801

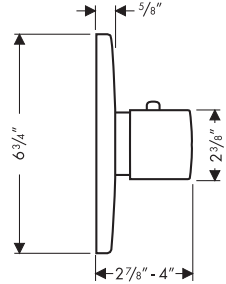

35375801  
35379801

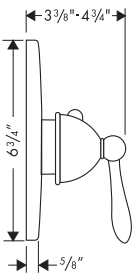

17384XX1  
17387XX1

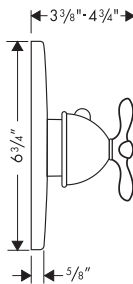

17385XX1  
17386XX1

## Installation

**!** Turn the water off at the main before beginning.

Remove the flush insert and o-rings.

**!** Save the screws!

Cut the i-box so that it extends  $1/16''$  outside the finished wall.

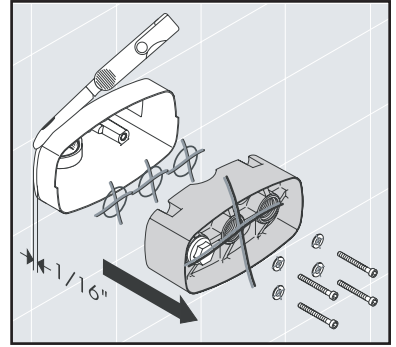

**!** Seal the wall around the i-box with waterproof sealant.

**!** Failure to seal the wall can lead to possible water damage.

Install the new o-rings.

Install the function block, using the reserved screws.

Turn on the water and check for leaks.

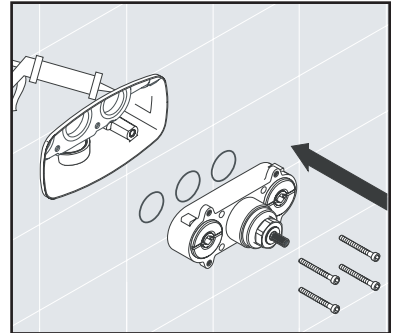

Install the trim carrier plate and screws.

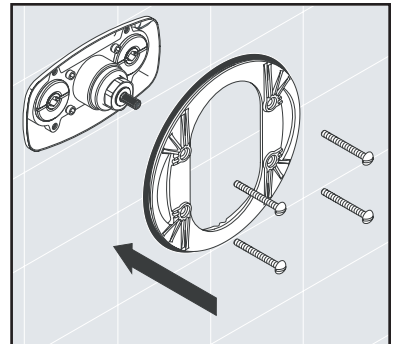

Install the trim sleeve with the indexing mark at the 12:00 position.

Push the escutcheon firmly over the carrier plate.

Install the handle adapter with the screw.

Install and justify the handle.

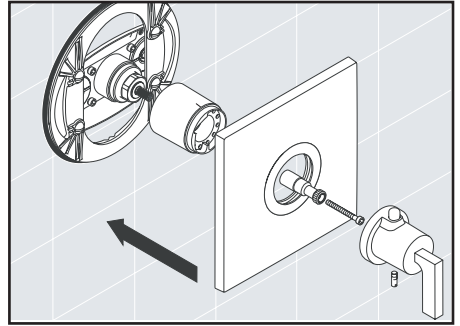
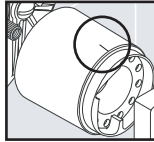

### Massaud only:

Install the two pieces of the sleeve – the safety set and the cover. Orient the safety set as shown.

Install the escutcheon.

Install the handle adapter and screw. Install and justify the handle.

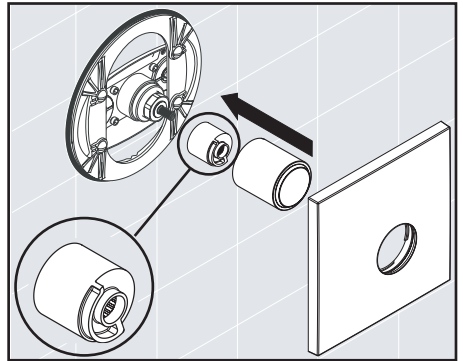

### Justify the handle

- Tools required: small slot-head screwdriver, thermometer

Remove the handle.

Place a thermometer in the water stream. Turn the stem until the water is 100° F.

Reinstall the handle so that the safety stop override button is at the 12:00 position. Tighten the screw.

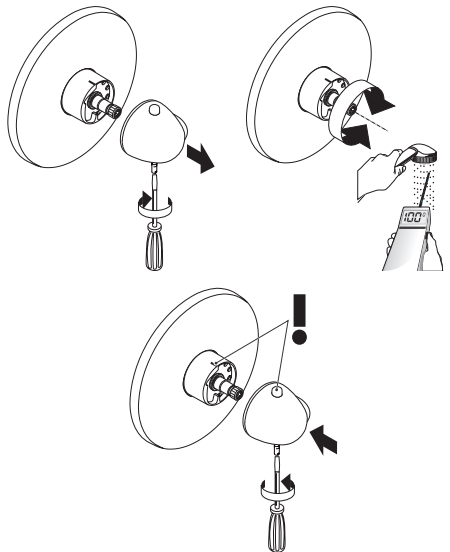

## Set the High Temperature Limit Stop (optional)

**IMPORTANT:** Many municipalities have codes limiting the maximum discharge temperature of a shower valve to 110° F or less. Please know and follow all applicable local codes when setting the high temperature limit stop. In Massachusetts, the maximum output temperature is 112° F.

- Tools Required: thermometer, small slot-head screwdriver

Turn the water on.

Loosen the set screw on the bottom of the handle. Remove the handle.

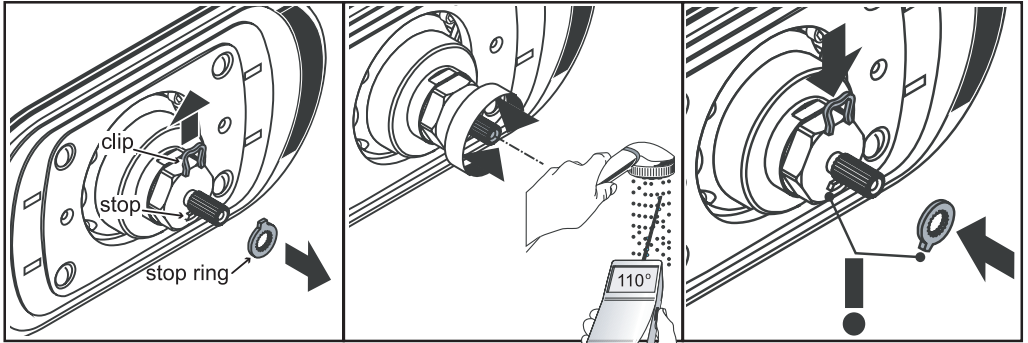

Remove the clip and stop ring from the stem.

Turn the stem until the water is the desired maximum high temperature – 110° in most areas.

Install the stop ring so that it is against the stop. Install the clip.

Justify and install the handle.

## User Instructions

Turn the handle clockwise to make the water cooler, counter-clockwise to make it warmer.

The handle will stop at the 100° safety stop. To obtain water hotter than 100°, push the safety stop override button and continue turning the handle counter-clockwise.

## The isolation stops

Close the stop by turning it clockwise with an 8 mm Allen wrench. Both stops must be closed!

- ! The water must be turned off at the main before the entire function block can be removed from the rough.

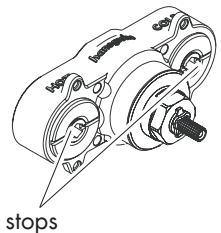

# Upgrade Kit 06800XX3

## Installation Considerations

- The upgrade kit contains an EcoMax function block, trim sleeve, and screws. It is used to upgrade an existing Ecostat installation.

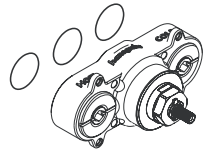

## Installation

- ! **Turn the water off at the main before proceeding.** Do not use the stops on the function block.

Remove the existing trim.

Remove the Ecostat function block and o-rings.

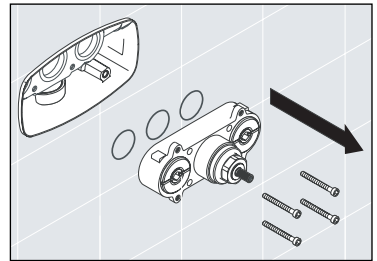

Install the EcoMax function block and o-rings.

Turn on the water to the valve and check for leaks.

Install the EcoMax sleeve.

Reinstall the trim.

Justify the handle.

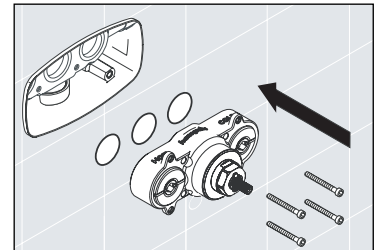



# Replacement Parts

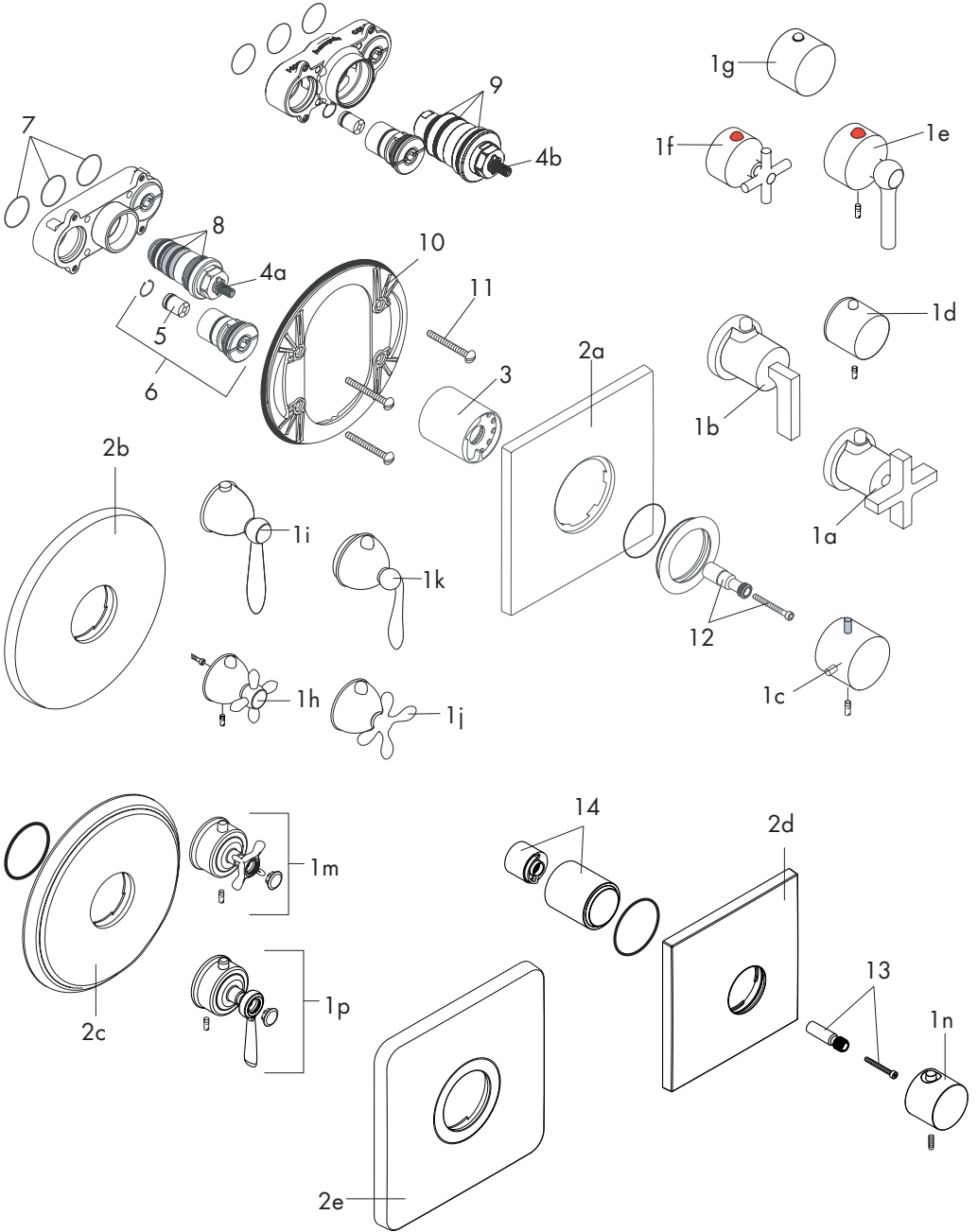

1a	Citterio cross handle	39994XX1	4a	Ecostat cartridge	94282000
1b	Citterio lever handle	39391XX1	4b	EcoMax cartridge	96633000
1c	Starck handle	10391XX1	5	check valve	95033000
1d	Steel handle	35391801	6	isolation stop	95036000
1e	Terrano handle, lever	37391XX1	7	seals	96364000
1f	Terrano handle, cross	37994XX1	8	seals	95037000
1g	Uno, Citterio M handle	38391XX1	9	seals	96636000
1h	Carlton handle, cross	17994XX1	10	carrier plate	96447000
1i	Carlton handle, lever	17391XX1	11	carrier plate screw	96454001
1j	Phoenix handle, cross	96631XX1	12	handle adapter	97108000
1k	Phoenix handle, lever	96791XX1	13	Massaud handle adapter	98701001
1m	Montreux handle	16594XX1	14	Massaud sleeve	98734001
1n	Massaud handle	18097000			
1p	Montreux lever handle	16694XX1			
2a	Escutcheon, square	96749XX0	XX = color		
2b	Escutcheon, round	96452XX0	00 = chrome		
2c	Escutcheon, Montreux	98648XX0	62 = oil rubbed bronze		
2d	Escutcheon, Massaud	98678000	80 = steel		
2e	Escutcheon, Citterio M	98917XX0	81 = satinox		
3	Ecostat sleeve	95032XX0	82 = brushed nickel		
	EcoMax sleeve	96635XX0	83 = polished nickel		

## Troubleshooting

Problem	Possible Cause	Solution
Too little water	Screens on thermostat cartridge are clogged	Remove and clean thermostat cartridge
Hot water is in cold water lines or vice versa	Check valves dirty or faulty	Clean or replace check valves
New installation: both hot and cold water are present, but do not mix	Hot and cold supplies are reversed	Remove the function block, turn it 180°, and reinstall
Water does not get hot enough	Handle is not justified	Justify handle
	High temperature limit stop not set properly	Set high temperature limit stop
	Thermostat cartridge is faulty	Replace thermostat cartridge

# Cleaning Recommendation for Hansgrohe Products

Modern lavatory faucets, kitchen faucets, and showers consist of very different materials to comply with the needs of the market with regard to design and functionality. To avoid damage and returns, it is necessary to consider certain criteria when cleaning.

## Cleaning Materials for Faucets and Showers

Acids are a necessary ingredient of cleaning materials for removing lime, however please pay attention to the following points when cleaning faucets and showers:

- Only use cleaning materials which are explicitly intended for this type of application.
- Never use cleaning materials which contain hydrochloric, formic, phosphoric, or acetic acid, as they cause considerable damage.
- Never mix one cleaning material with another.
- Never use cleaning materials or appliances with an abrasive effect, such as unsuitable cleaning powders, sponge pads, or micro fiber cloths.

## Cleaning Instructions for Faucets and Showers

Please follow the cleaning material manufacturer's instructions. In addition, pay attention to the following points:

- Clean the faucets and showers as and when required
- Use the amount of cleaning product and the amount of time recommended by the manufacturer. Do not leave the cleaner on the fixture longer than necessary.
- Regular cleaning can prevent calcification.
- When using spray cleaners, spray first onto a soft cloth or sponge. Never spray directly onto the faucet as droplets can enter openings and gaps and cause damage.
- After cleaning, rinse thoroughly with clean water to remove any cleaner residue.

## Important

Residues of liquid soaps, shampoos, and shower foams can also cause damage, so rinse with clean water after using.

**Please note:** if the surface is already damaged, the effect of cleaning materials will cause further damage.

**Components with damaged surfaces must be replaced or injury could result.**

**Damage caused by improper treatment is not covered under the warranty.**

# Limited Lifetime Consumer Warranty

This product has been manufactured and tested to the highest quality standards by Hansgrohe, Inc. ("Hansgrohe"). This warranty is limited to Hansgrohe products which are purchased by a consumer in the United States after March 1, 1996, and installed in either the United States or Canada.

## WHO IS COVERED BY THE WARRANTY

This warranty extends to the original consumer purchaser only. This warranty is non-transferable.

## WHAT IS COVERED BY THE WARRANTY

This warranty covers only your Hansgrohe manufactured product. Hansgrohe warrants this product against defects in material or workmanship as follows: Hansgrohe will repair at no charge for parts only or, at its option, replace any product or part of the product that proves defective because of improper workmanship and/or material, under normal installation, use, service and maintenance. If Hansgrohe is unable to provide a replacement and repair is not practical or cannot be timely made, Hansgrohe may elect to refund the purchase price in exchange for the return of the product.

## LENGTH OF WARRANTY

Replacement or repaired parts of products will be covered for the term of this warranty as stated in the following two sentences. If you are a consumer who purchased the product for use primarily for personal, family, or household purposes, this warranty extends for as long as you own the product and the home in which the product is originally installed. If you purchased

the product for use primarily for any other purpose, including, without limitation, a commercial purpose, this warranty extends only (i) for 1 year, with respect to Hansgrohe and Commercial products, and (ii) for 5 years, with respect to AXOR products.

THIS WARRANTY DOES NOT COVER, AND HANSGROHE WILL NOT PAY FOR:

- A. Conditions, malfunctions or damage not resulting from defects in material or workmanship.
- B. Conditions, malfunctions or damage resulting from (1) normal wear and tear, improper installation, improper maintenance, misuse, abuse, negligence, accident or alteration, or (2) the use of abrasive or caustic cleaning agents or "no-rinse" cleaning products, or the use of the product in any manner contrary to the product instructions. (3) Conditions in the home such as excessive water pressure or corrosion.
- C. Labor or other expenses for the disconnection, deinstallation, or return of the product for warranty service, or for installation or reinstallation of the product (including but not limited to proper packaging and shipping costs), or for installation or reinstallation of the product.
- D. Accessories, connected materials and products, or related products not manufactured by Hansgrohe.

TO OBTAIN WARRANTY PARTS OR INFORMATION

Contact your Hansgrohe retailer, or contact Technical Service at:

Hansgrohe Inc.  
1492 Bluegrass Lakes Parkway  
Alpharetta GA 30004  
Toll-free (800) 334-0455.

In requesting warranty service, you will need to provide

- 1. The sales receipt or other evidence of the date and place of purchase.
- 2. A description of the problem.
- 3. Delivery of the product or the defective part, postage prepaid and carefully packed and insured, to Hansgrohe Inc. 1492 Bluegrass Lakes Parkway, Alpharetta, Georgia 30004, Attention: Technical Service, if required by Hansgrohe.

When warranty service is completed, any repaired or replacement product or part will be returned to you postage prepaid.

EXCLUSIONS AND LIMITATIONS

REPAIR OR REPLACEMENT (OR, IN LIMITED CIRCUMSTANCES, REFUND OF THE PURCHASE PRICE) AS PROVIDED UNDER THIS WARRANTY IS THE EXCLUSIVE REMEDY OF THE PURCHASER. HANSGROHE NEITHER ASSUMES NOR AUTHORIZES ANY PERSON TO CREATE FOR IT ANY OBLIGATION OR LIABILITY IN CONNECTION WITH THIS PRODUCT.

HANSGROHE SHALL NOT BE LIABLE TO PURCHASER OR ANY PERSON FOR ANY INCIDENTAL, SPECIAL, OR CONSEQUENTIAL DAMAGES, ARISING OUT OF BREACH OF THIS WARRANTY OR ANY IMPLIED WARRANTY (INCLUDING MERCHANTABILITY).

Some States do not allow the exclusion or limitation of incidental or consequential damages, so the above limitation or exclusion may not apply to you. This warranty gives you specific legal rights, and you may have other rights which vary from State to State. You may be required by law to give us a reasonable opportunity to correct or cure any failure to comply before you can bring any action in court against us under the Magnuson-Moss Warranty Act.

PRODUCT INSTRUCTIONS AND QUESTIONS

Upon purchase or prior to installation, please carefully inspect your Hansgrohe product for any damage or visible defect. Prior to installing, always carefully study the enclosed instructions on the proper installation and the care and maintenance of the product. If you have questions at any time about the use, installation, or performance of your Hansgrohe product, or this warranty, please call or write to us or call us toll-free at 800 334 0455.

**hansgrohe**

Hansgrohe, Inc. • 1490 Bluegrass Lakes Parkway • Alpharetta, GA 30004  
Tel. 770-360-9880 • Fax 770-360-9887

[www.hansgrohe-usa.com](http://www.hansgrohe-usa.com)