

Installation Instructions / Warranty

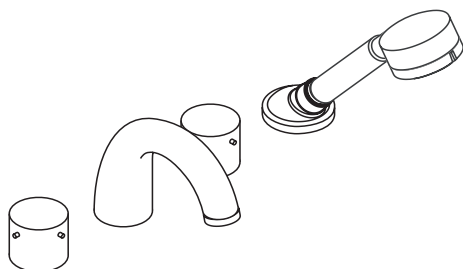

Starck
10444XX1
10454XX1

AXOR[®]
hansgrohe

90564101
06/2005

Starck 4-Hole Roman Tub Trim

10444XX1

10454XX1

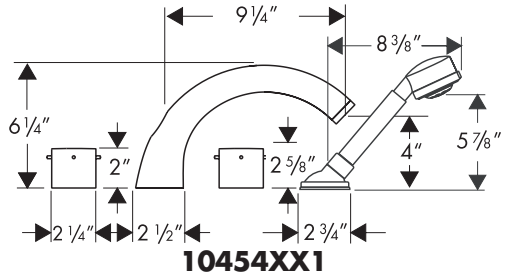
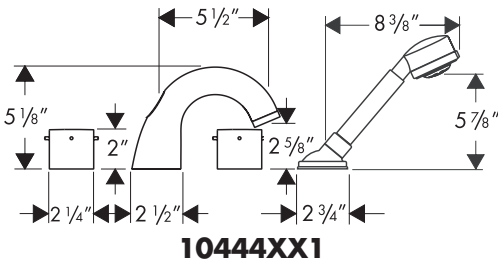

Installation Considerations

- This trim kit must be used with rough-in 13444-181. The handshower must be used.
- Backflow protection is provided by a check valve in the handshower connection hose. Additionally, the diverter will automatically spring back to the "spout" position if a backflow condition exists.

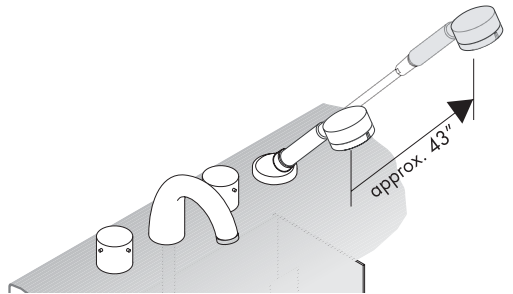

Product Specifications

Recommended operating pressure	45 - 80 psi
Recommended hot water temperature	120° - 140° F*
Flow rate - handshower	2.5 gpm
Flow rate - valves	approx. 6 gpm each
Hole sizes - see template included with rough-in for placement	
Valves	1 3/16"
Spout	1 3/8"
Spout Adapter Pin	3/16"
Handshower	2"
Maximum mounting surface thickness	2"

90° Ceramic cartridge operation.

* Some governing agencies require that the water heater be set to 120o F or less. Please know and follow all applicable local codes when setting the temperature on the water heater.

Replacement Parts

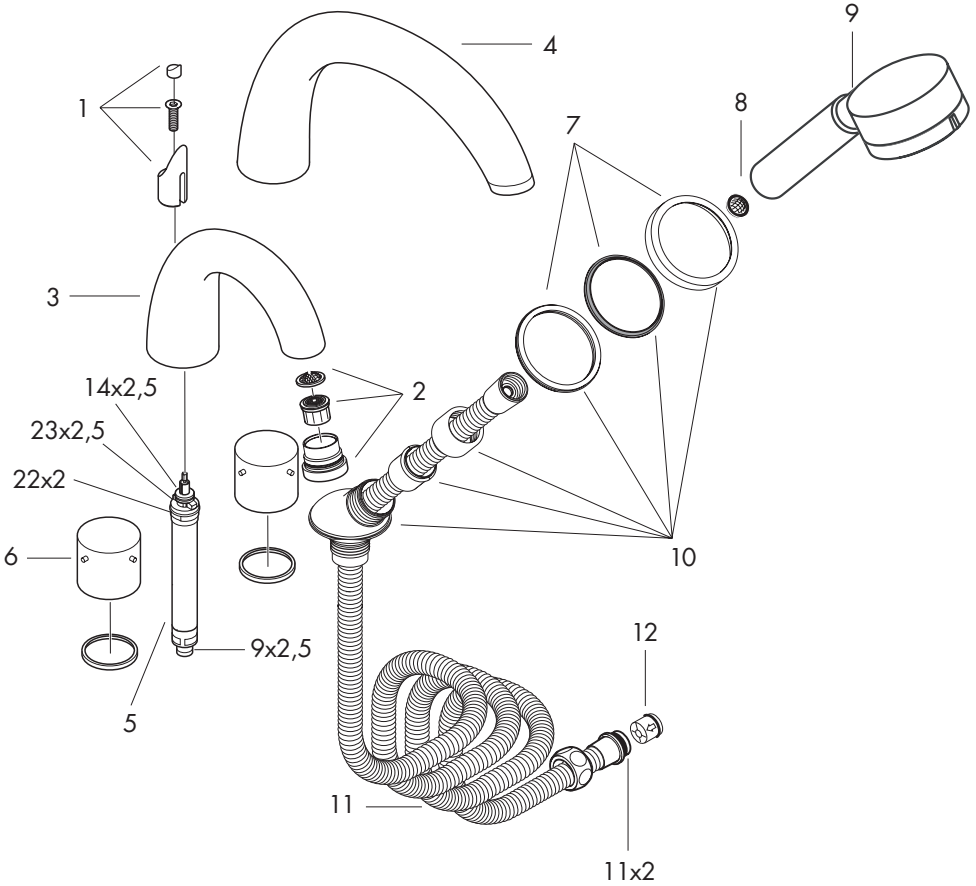

1	diverter knob	96086XX0	XX = Colors
2	aerator cpl.	94034XX0	00 = chrome
3	spout cpl. 10444XX1	96163XX0	81 = satinox
4	spout cpl. 10458XX1	96138XX0	82 = brushed nickel
5	selector assy	94037000	
6	handle	10991XX0	
7	escutcheon for shower holder	94052XXX	
8	filter packing (25)	94246000	
9	handshower	38885XX1	
10	shower holder, assy	92380XX0	
11	hose 2,00 m	94148000	
12	check valve	94074000	

Installation Instructions

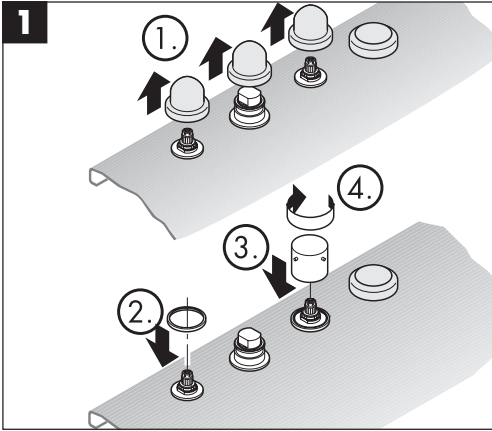

- Remove the plaster guards (1) from the valve corners and the spout adapter.
- Install the glide rings (2)
- Install the handles (3) by pressing firmly over the handle snap connectors.
- Turn the handles clockwise to make sure that the valves are in the "off" position.

CAUTION: Do not install the handles unless the snap connectors are screwed firmly to the stems.

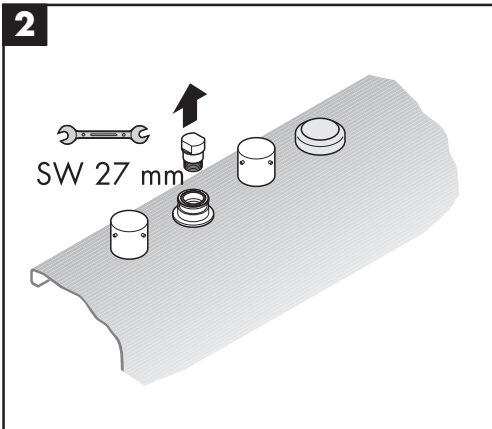

- Remove the plug from the spout adapter using a 27 mm wrench.

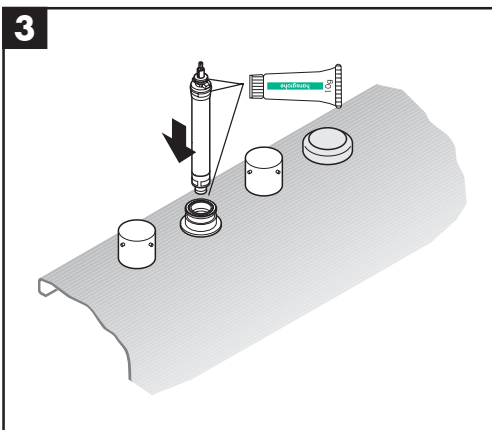

- Lubricate the o-rings on the diverter with the enclosed lubricant. Install the diverter by pushing firmly straight down into the spout adapter.
- **CAUTION:** Do not remove the female fitting and the white plastic clip from the top of the diverter assembly! These parts are necessary for the installation of the diverter knob.

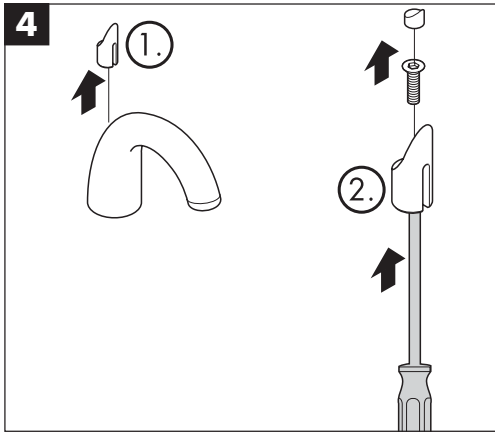

- Remove the diverter knob from the spout (1). Use a small screwdriver to push the screw and screw cover from the diverter knob (2).

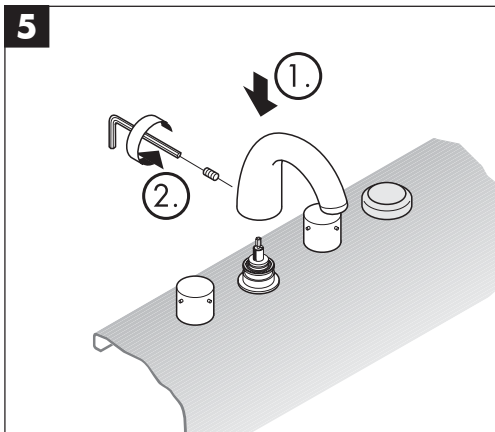

- Install the spout (1) to the spout adapter over the diverter. Tighten the set screw (2) with the enclosed 3 mm allen wrench.

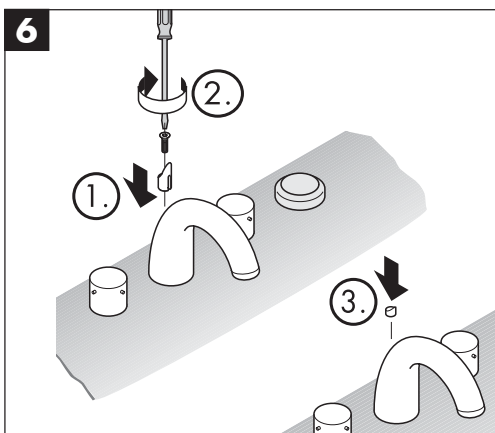

- Install the diverter knob (1) and screw (2), using a small screwdriver (not included). The screw will engage the female fitting on the diverter stem.
- Install the grey screw cover (3).

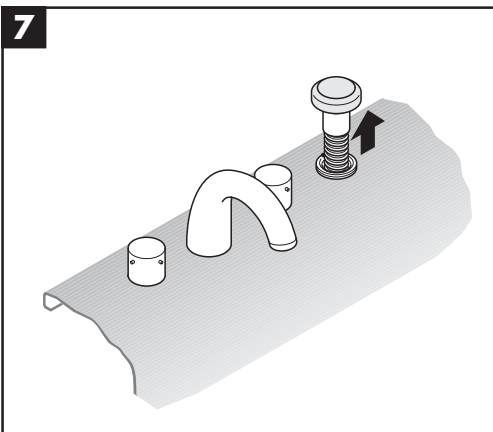

- Pull the outer Secuflex™ hose through the handshower mount.

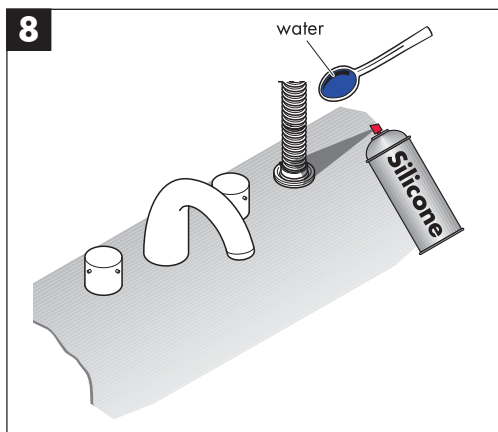

- Lubricate the handshower mount and outer Secuflex™ hose with spray silicon lubricant or with a tablespoon or so of water.

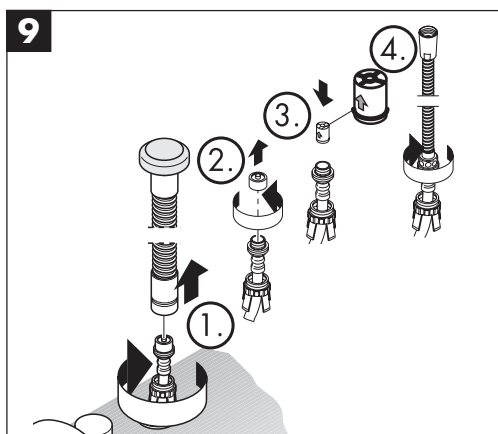

- Pull the outer Secuflex™ hose completely from the handshower mount. Unscrew the outer Secuflex™ hose (1) from the handshower connector hose (2). Do not allow the handshower connector hose to fall back through the hole!
- Remove the brass plug (3) from the handshower connector hose (2).
- Install the check valve (4) to the handshower connector hose.

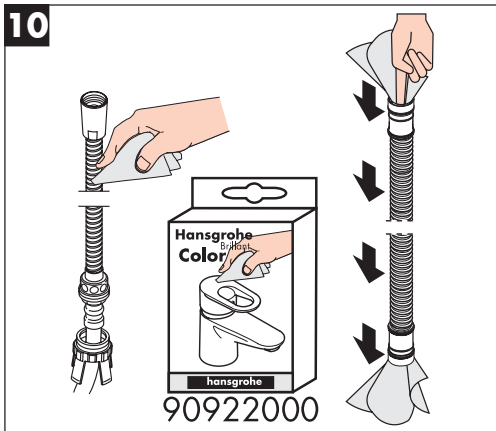

- Use the enclosed cleaning towelette to thoroughly clean the outer Secuflex™ hose.

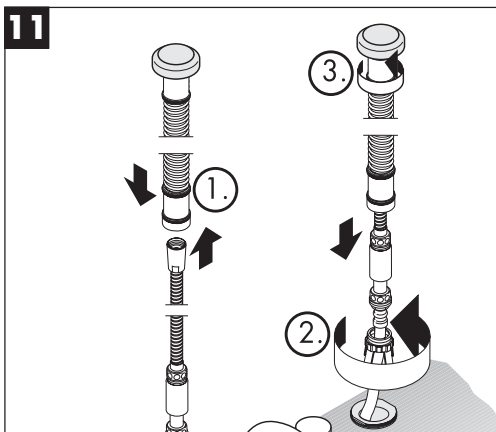

- Feed the inner Secuflex™ hose through the outer Secuflex™ hose (1)
- Attach the inner Secuflex™ hose to the handshower connector hose (2).
- Remove the plaster guard from the outer Secuflex™ hose (3).

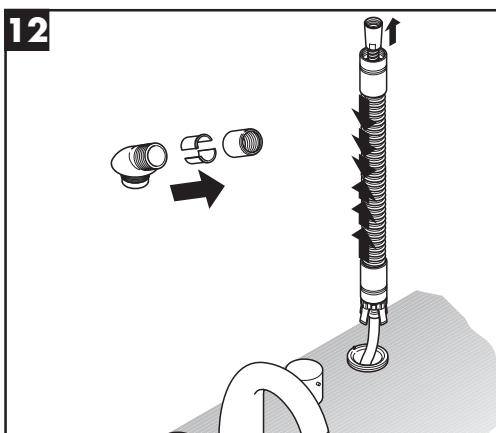

- Remove the end cap and the liner from the handshower holder.
- Compress the outer hose until you can grasp the end of the inner hose

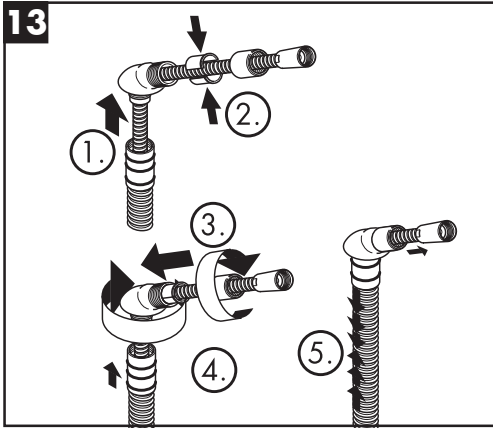

- Feed the inner hose through the handshower holder (1), liner (2), and end cap (3).
- Screw the end cap (4) over the end of the handshower holder.
- Continue pulling "out" on the inner hose (5).

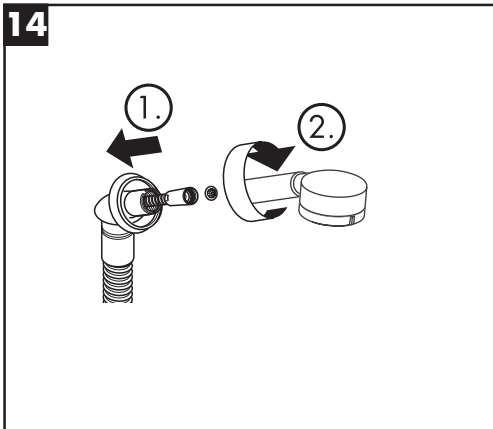

- Place the handshower holder retainer ring (1) over the hose and the handshower holder.
- Install the screen washer and the handshower on the hose (2).

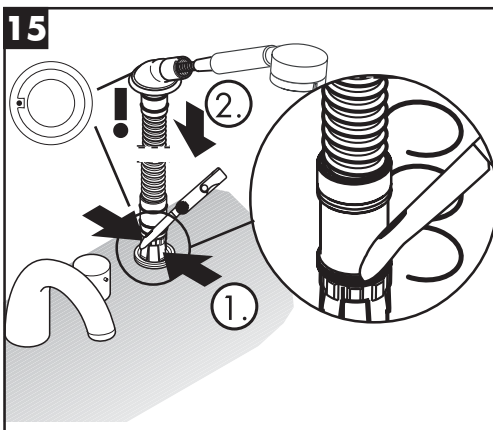

- Use a knife to cut the o-rings at the end of the outer hose.
- Feed the hoses back through the handshower mount.
- Place the handshower holder onto the handshower mount so that the pin on the mount engages the corresponding hole on the handshower holder.

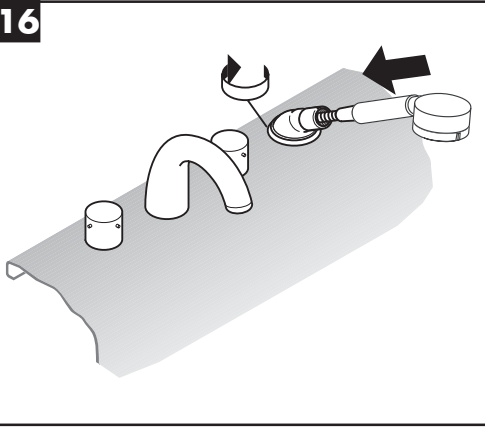
16

- Secure the handshower holder to the handshower mount with the retainer ring.

User Instructions

- Turn the left handle for hot water, the right handle for cold.
- Pull up on the diverter knob to divert the water to the handshower. The diverter will automatically reset to the tub spout when the water is turned off.
- The handshower uses the Rubit!TM self cleaning system. The spray channels are lined with a material that resists scale deposits. If scale is noticed, turn the water on lightly and rub across the channels with a thumb or a sponge to clear them of deposits.
- The check valve should be removed, inspected, and cleaned yearly.

Cleaning Recommendation for Hansgrohe Products

Modern faucetry and shower products utilize a combination of materials to comply with the needs of the market with regard to design and functionality.

To avoid damage, it is necessary to use some caution when cleaning. Damage caused by improper treatment is not covered under the Hansgrohe warranty.

Cleaning Materials for Faucets and Showers

- To remove lime scale, use only products made specifically for that purpose. Always follow the manufacturer's instructions when using.
- Do not use cleaners that contain hydrochloric, formic, acetic, or phosphoric acids, as these will cause considerable damage to finishes and to plastic components.
- Never mix cleaning materials.
- Never use cleaners containing abrasives. Do not use abrasive cleaning cloths, pads, or sponges.

Cleaning Procedures

- Clean your faucets and shower products as and when required. Regular cleaning will prevent scale buildup and water spotting.
- Follow the label instructions. Do not allow any cleaner to remain on the product for longer than necessary.
- When using spray cleaners, spray first onto a sponge or cloth – do not spray directly onto the product.
- After cleaning, rinse thoroughly with clear water to remove any cleaner residue.

Important

- Soap and shampoo residue can also cause damage to the product. Rinse well with clean water after use.
- If the surface is already damaged, harsh cleaning materials will cause further damage.

Limited Lifetime Consumer Warranty

This product has been manufactured and tested to the highest quality standards by Hansgrohe, Inc. ("Hansgrohe"). This warranty is limited to Hansgrohe products which are purchased by a consumer in the United States after March 1, 1996, and installed in either the United States or Canada.

WHO IS COVERED BY THE WARRANTY

This warranty extends to the original consumer purchaser only.

WHAT IS COVERED BY THE WARRANTY

This warranty covers only your Hansgrohe manufactured product. Hansgrohe warrants this product against defects in material or workmanship as follows: Hansgrohe will repair at no charge for parts only or, at its option, replace any product or part of the product which proves defective because of improper workmanship and/or material, under normal installation, use, service and maintenance. If Hansgrohe is unable to provide a replacement and repair is not practical or cannot be timely made, Hansgrohe may elect to refund the purchase price in exchange for the return of the product.

LENGTH OF WARRANTY

Replacement or repaired parts of products will be covered for the term of this warranty as stated in the following two sentences. If you are a consumer who purchased the product for use primarily for personal, family, or household purposes, this warranty extends for as long as you own the product and the home in which the product is installed. If you purchased the product for use primarily for any other purpose, including, without limitation, a commercial purpose, this warranty extends only (i) for 1 year, with respect to Interaktiv and Retroaktiv products, and (ii) for 5 years, with respect to AXOR, ShowerPower and Pharo products.

THIS WARRANTY DOES NOT COVER, AND HANSGROHE WILL NOT PAY FOR:

- A. Conditions, malfunctions or damage not resulting from defects in material or workmanship.
- B. Conditions, malfunctions or damage resulting from (1) improper installation, improper maintenance, misuse, abuse, negligence, accident or alteration, or (2) the use of abrasive or caustic cleaning agents or "no rinse" cleaning products, or the use of the product in any manner contrary to the product instructions.
- C. Labor or other expenses for the disconnection or return of the product for warranty service, or for installation or reinstallation of the product.
- D. Accessories or related products not manufactured by Hansgrohe.

TO OBTAIN WARRANTY SERVICE

Contact your Hansgrohe retailer, or write to Technical Service at:

Hansgrohe Inc.
1492 Bluegrass Lakes Parkway
Alpharetta GA 30004

Or, call Hansgrohe toll-free at (800) 334-0455.

In requesting warranty service, you will need to provide

- 1. The sales receipt or other evidence of the date and place of purchase.
- 2. A description of the problem.
- 3. Delivery of the product or the defective part, postage prepaid and carefully packed and insured, to Hansgrohe Inc. 1492 Bluegrass Lakes Parkway, Alpharetta, Georgia 30004, Attention: Technical Service, if required by Hansgrohe.

When warranty service is completed, any repaired or replacement product or part will be returned to you postage prepaid.

EXCLUSIONS AND LIMITATIONS

REPAIR OR REPLACEMENT (OR, IN LIMITED CIRCUMSTANCES, REFUND OF THE PURCHASE PRICE) AS PROVIDED UNDER THIS WARRANTY IS THE EXCLUSIVE REMEDY OF THE PURCHASER. HANSGROHE NEITHER ASSUMES NOR AUTHORIZES ANY PERSON TO CREATE FOR IT ANY OBLIGATION OR LIABILITY IN CONNECTION WITH THIS PRODUCT.

HANSGROHE SHALL NOT BE LIABLE TO PURCHASER OR ANY PERSON FOR ANY INCIDENTAL, SPECIAL, OR CONSEQUENTIAL DAMAGES, ARISING OUT OF BREACH OF THIS WARRANTY OR ANY IMPLIED WARRANTY (INCLUDING MERCHANTABILITY).

Some States do not allow the exclusion or limitation of incidental or consequential damages, so the above limitation or exclusion may not apply to you.

This warranty gives you specific legal rights, and you may have other rights which vary from State to State.

You may be required by law to give us a reasonable opportunity to correct or cure any failure to comply before you can bring any action in court against us under the Magnuson-Moss Warranty Act.

PRODUCT INSTRUCTIONS AND QUESTIONS

Upon purchase or prior to installation, please carefully inspect your Hansgrohe product for any damage or visible defect. Prior to installing, always carefully study the enclosed instructions on the proper installation and the care and maintenance of the product. If you have questions at any time about the use, installation, or performance of your Hansgrohe product, or this warranty, please call or write to us at the toll-free number and address printed above.

hansgrohe

Hansgrohe, Inc. • 1490 Bluegrass Lakes Parkway • Alpharetta GA 30004
Tel 770 360-9880 • Fax 770 360-9887
www.hansgrohe-USA.com