

# Lindale™ Technical Specification

## Towel Ring

Y3186

### Stock Numbers:

- ❑ Y3186BN – Towel Ring  
Brushed Nickel Finish
- ❑ Y3186BRB – Towel Ring  
Mediterranean Bronze Finish
- ❑ Y3186CH – Towel Ring  
Chrome Finish

### Dimensions:

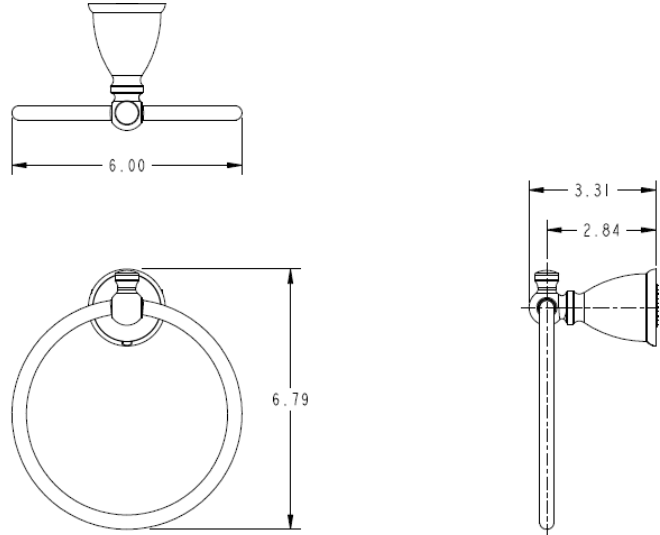

### Materials:

**Towel Ring** post is die cast from highest quality zinc alloy (Zamac). Casting is plated in Chrome, Brushed Nickel or Mediterranean Bronze. **Towel Ring** is aluminum for Chrome and Brushed Nickel finishes and Stainless Steel for Mediterranean Bronze.

### Installation Instructions:

1. Remove mounting plate from hardware pack.
2. Position the mounting plate on the wall at desired location with "UP" facing you. Mark hole locations.
3. Drill 2 holes as marked using 5/16" drill bit.
4. Fold ends of the plastic toggle anchor together and insert into each hole in the wall.
5. Lightly tap anchors until flush with the wall.
6. One at a time, insert plastic pin into each anchor and lightly tap to activate anchor. Remove pin and repeat on other anchor.
7. Place the mounting plate on the wall over the installed wall anchors with "UP" facing you.
8. Tighten screws.
9. Place decorative product over the mounting plate with setscrew facing down and tighten setscrew.

### Cleaning Instructions:

To preserve the fine finish of this product, clean only with a soft damp cloth. Dry well. Do not use commercial or abrasive cleaners.

**Stock Number:** \_\_\_\_\_ **Towel Ring**  
By Creative Specialties



25300 AL MOEN DRIVE • NORTH OLMS TED, OH 44070  
CORPORATE HEADQUARTERS: (800) 321-8809 • FAX: (800) 848-6636  
INTERNATIONAL: (440) 962-2000 • FAX: (440) 962-2726  
CUSTOMER SERVICE (USA): 800-882-0116 • FAX: (888) 379-2720  
WWW.CSI.MOEN.COM

©Copyright Creative Specialties International

Literature # BA1536