



Incandescent

Directional

Directionals

Catalog No.	Finish			Lamping	Dimensions (Inches)		
	Brushed Nickel	White	Urban Bronze		A	B	C
P6149	-09	-30	-174	2 PAR-20 50w	8-1/8	12-1/8	6-1/2

Type	-09	-30	-174
P6149	<input type="checkbox"/>	<input type="checkbox"/>	<input type="checkbox"/>

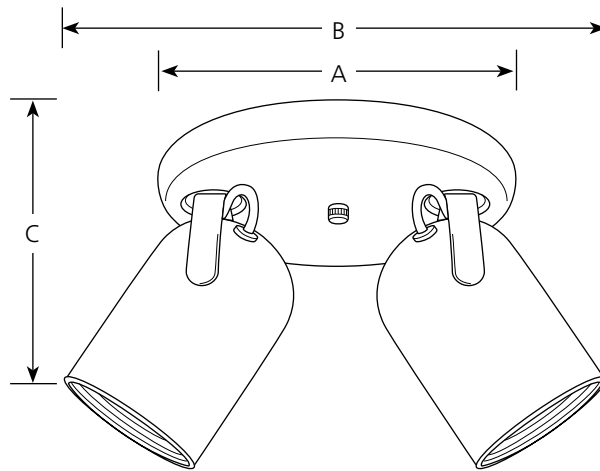

P6149

Specifications:

General

- Plated Brushed Nickel (-09) finish
- White (-30) or Urban Bronze (-174) finishes
- Steel construction
- Complete with black plastic baffle
- 180 degree vertical and 360 degree horizontal adjustment
- Matching single and three lamp units available.
- Solid round back style

Mounting

- Ceiling mount
- Canopy covers a standard 4" hexagonal recessed outlet box
- Mounting strap for outlet box included

Electrical

- Medium base sockets
- Pre-wired

Labeling

- cCSAus Damp location listed

Progress Lighting
 701 Millennium Blvd.
 Greenville, South Carolina
 29607

www.progresslighting.com

Rev. 02/14