

# THIS SPACE FOR DESIGNER/ ENGINEER APPROVAL

Job/Customer \_\_\_\_\_ Date \_\_\_\_\_ Contractor \_\_\_\_\_

Model Specified \_\_\_\_\_ Qty \_\_\_\_\_ Approved By \_\_\_\_\_

Designer/Engineer \_\_\_\_\_ Date \_\_\_\_\_ Contractor's PO# \_\_\_\_\_

Submitted by \_\_\_\_\_ Date \_\_\_\_\_ Other \_\_\_\_\_

## 4140 Series & 4140HV

**FULL PORT FORGED BRASS  
UNI-FLANGE BALL VALVES  
W/ DETACHABLE ROTATING FLANGE  
BONUS WING STYLE "T" HANDLE,  
NUTS & BOLTS  
IPS x ROTATING FLANGE  
600 WOG - ISO 9001:2000**



**The Only Way To  
Isolate Circulator Pumps**

ITEM #	SIZE	P/CARTON	P/CASE	A	B	C	D	E	F	G	H	I
41403	3/4"	2	20	3/4	2 5/8	3 15/16	4	3/8	1/2	1	2 11/16	4 3/16
41404	1"	2	20	1	3 1/8	3 1/2	4 5/8	3/8	1/2	1 1/4	2 11/16	4 3/16
41405	1 1/4"	2	20	1 1/4	3 15/16	2 15/16	4 5/8	3/8	1/2	1 9/16	2 11/16	4 3/16
41406	1 1/2"	2	20	1 1/4	3 15/16	3 3/8	5 1/2	3/8	1/2	1 15/16	2 11/16	4 3/16
41403HV	3/4"	2	20	3/4	2 5/8	3 15/16	4	3/8	5/8	1	2 11/16	4 3/16
41404HV	1"	2	20	1	3 1/8	3 1/2	4 5/8	3/8	5/8	1 1/4	2 11/16	4 3/16
41405HV	1 1/4"	2	20	1 1/4	3 15/16	2 15/16	4 5/8	3/8	5/8	1 9/16	2 11/16	4 3/16
41406HV	1 1/2"	2	20	1 1/4	3 15/16	3 3/8	5 1/2	3/8	5/8	1 15/16	2 11/16	4 3/16

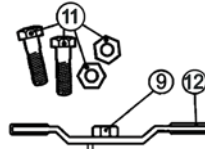

NO.	DISCRIPTION	MATERIAL
1	FLANGED BODY	BRASS
2	END CAP	BRASS
3	SEATS	PTFE
4	BALL	BRASS HCP
5	STEM	BRASS
6	STEM SEAL	PTFE
7	PACKING GLAND	BRASS
8	LEVER HANDLE	CP STEEL
9	HANDLE NUT	BRASS
10	HANDLE JACKET	VINYL
11	FLANGE BOLTS & NUTS	STEEL
12	WING STYLE "T" HANDLE	CP STEEL W/ VINYL GRIPS
13	ROTATING FLANGE	BRASS
14	FLANGE RING	ABS

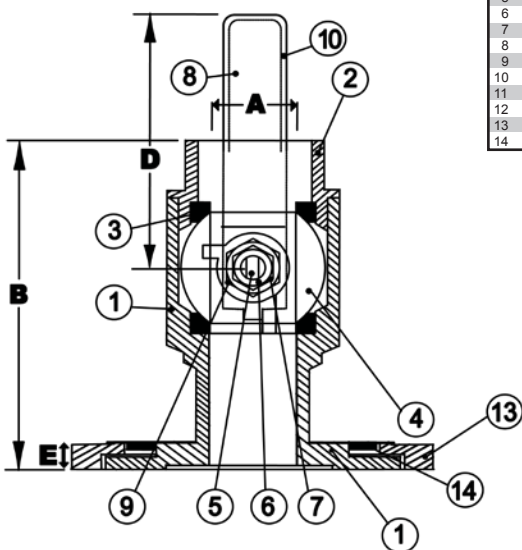
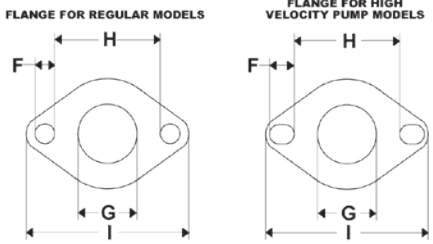

TEMP °F	WOG
100	600
150	490
200	470
250	439
300	411
350	294
366	N/A

Specifications: Designed for residential, commercial or industrial use with water, oil or gas. This approved Webstone Valve is actuated by a blowout proof stem and features an adjustable packing nut. Threaded ends comply with ANSI B1.20.1

**Webstone** Company, Inc.  
www.webstonevalves.com

Quality and Commitment Since 1954

Tel: (800) 225-9529 • Fax (800) 336-5133

Webstone product specifications in U.S. customary units are approximate and are provided for reference only. Webstone reserves the right to change or modify product design, construction, specifications or materials without prior notice and without incurring any obligation to make such changes and modifications on Webstone products previously or subsequently sold. The Isolator® is a registered trademark of Webstone Company, Inc.