

THIS SPACE FOR DESIGNER/ ENGINEER APPROVAL

Job/Customer _____ Date _____ Contractor _____

Model Specified _____ Qty _____ Approved By _____

Designer/Engineer _____ Date _____ Contractor's PO# _____

Submitted by _____ Date _____ Other _____

5070 Series FULL PORT FORGED BRASS BALL VALVES W/ REVERSIBLE HANDLE CxC 600 WOG / 150 WSP - ISO 9001:2000

ITEM #	SIZE	P/CARTON	P/CASE	A	B	C	D	Cv
50702	1/2"	10	100	1/2	2 3/16	2	3 1/4	11.5
50703	3/4"	5	60	3/4	2 7/8	2 1/16	4 3/8	27.0
50704	1"	5	40	1	3 1/2	2 3/8	4 3/8	49.3
50705	1 1/4"	4	28	1 1/4	3 7/8	2 3/4	5 5/8	114.0
50706	1 1/2"	4	20	1 1/2	4 1/2	3	5 5/8	168.5
50707	2"	2	12	2	5 1/2	3 5/8	6 3/8	255.8

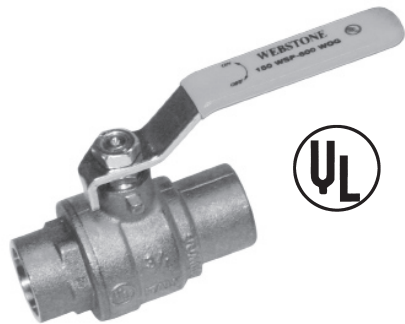

NO.	DESCRIPTION	MATERIAL
1	BODY	BRASS
2	END CAP	BRASS
3	SEAT	PTFE
4	BALL	BRASS HCP
5	STEM	BRASS
6	STEM SEAL	PTFE
7	PACKING GLAND	BRASS
8	HANDLE NUT	STEEL CP
9	HANDLE NUT	STEEL CP
10	HANDLE JACKET	VINYL

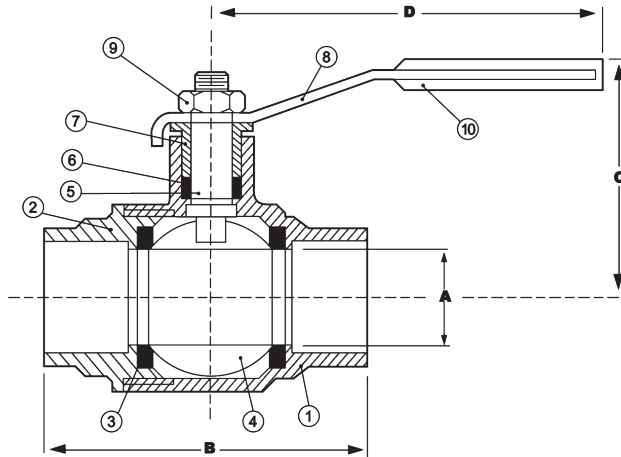

TEMP °F	WOG
100	600
150	485
200	395
250	210
300	N/A
350	N/A
366	N/A

Specifications: Designed for residential, commercial or industrial use with water, oil or gas. This approved Webstone valve is actuated by a blowout proof stem and features an adjustable packing nut. UL Listed. Solder joint temperature ratings are per ASME B16.18 Annex A for 95-5 solder. Other solder materials have lower pressure/temperature limits. Do not silver braze or over heat valves when soldering.

Webstone Company, Inc.
www.webstonevalves.com

Quality and Commitment Since 1954

Tel: (800) 225-9529 • Fax (800) 336-5133

Webstone product specifications in U.S. customary units are approximate and are provided for reference only. Webstone reserves the right to change or modify product design, construction, specifications or materials without prior notice and without incurring any obligation to make such changes and modifications on Webstone products previously or subsequently sold.

5070spec_101909