



SPECIFICATIONS  
**FRAK100**  
 EXHAUST FAN



100 CFM/1.5 Sones @ 0.10" SP., 87 CFM @ 0.25" SP., 30.5 Watts

- **Grill**  
Cold rolled steel, powder coated white.
  - **Blower Wheel**  
One piece polymeric centrifugal blower wheel, 5.22" diameter, 2.90" wide, with 30 paddles.
  - **Motor**  
Heavy duty, permanently split capacitor, 4 pole motor, life time lubrication, thermally protected. Rated 120 volts, 0.31 amps.  
**Contractor Pack (Motor/BladeGrill) Model: FAK100T\***
  - **Fan Housing**  
24 gauge galvanized steel housing, dimensions 10<sup>3</sup>/<sub>4</sub>" x 9<sup>1</sup>/<sub>4</sub>" x 7<sup>7</sup>/<sub>8</sub>".  
**Contractor Pack Model: AKFH2\***
  - **Duct Collar**  
Metal collar for 4" duct connection, comes complete with built in back draft damper.
  - **Ventilating Area**  
For rooms up to 125 sq. ft.
  - **Unit Mounting**  
FRAK100 is centered between joists (with 16" centers) using hanging brackets. The housing will mount through drywall thickness up to 3/4", with a rough-in opening of 10<sup>3</sup>/<sub>4</sub>" x 9<sup>1</sup>/<sub>4</sub>".
- \* Sold in packs of 4. All three parts (housing, damper, motor/blade/grill) must be purchased and used together to make a complete unit.

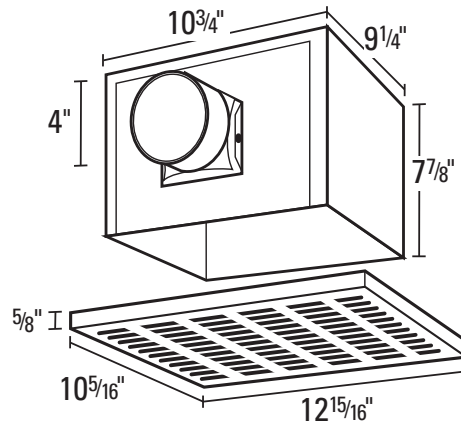

Acceptable for use over tub or shower when installed in a GFCI protected branch circuit.



- **Damper**  
**Blanket** - Non-asbestos, ceramic blanket  
**Fusible Link** - Replaceable, 165°F standard  
**Classification** - CUL Listed 555C. California State Marshall classification for 1 hour fire damper rating. California State Marshall listing number 3225-1374-101.  
**Contractor Pack Model: AKFD2\***

EXPANDED PERFORMANCE											
	Static Pressure (inches of w.g.)							Sones @ .1 SP	Sones @ .25 SP	Fan Speed RPM	Power Watts
	0	0.05	0.1	0.125	0.15	0.2	0.25				
<b>Air Flow - CFM</b>	108	104	100	99	97	93	87	1.5	1.5	1177	30.5

<b>PROJECT</b>							<b>ARCHITECT</b>				
<b>LOCATION</b>							<b>ENGINEER</b>				
<b>CONTRACTOR</b>							<b>SUBMITTED BY</b>			<b>DATE</b>	
FAN NUMBER	MODEL NUMBER	CFM	IN W.G.	RPM	WATTS	AMPS	SONES	QTY	OPTIONAL EQUIPMENT & REMARKS		



U.S.: 820 Lincoln Avenue  
 West Chester, Pennsylvania 19380-4466  
 Tel: (610) 692-7400 • 877-304-3785  
 Fax: (610) 696-8048

Canada: 8 Edvac Drive  
 Brampton, Ontario L6S 5P2  
 Tel: (905) 456-2033  
 Fax: (905) 456-1015