

Type \_\_\_\_\_

-30EB -31EB

P7340

P7341

Catalog No.	Finish		Lamping	Dimensions (Inches)	
	White	Black		A	B
P7340	-30EB	-31EB	1-26w Triple tube CFL	8-1/4	4-3/4
P7341	-30EB	-31EB	2-26w Triple tube CFL	10-1/4	5-1/2

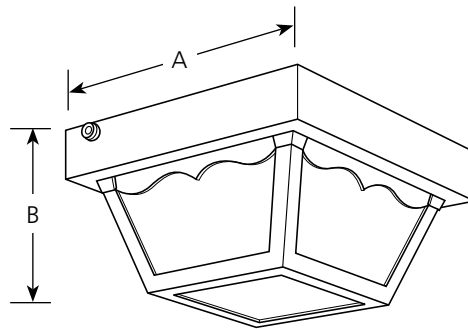

P7340

**Specifications:**

General

- One piece white acrylic diffuser
- UV resistant
- Polypropylene housing
- Galvanized steel back plate
- White (-30EB) or Black (-31EB) polypropylene material

Mounting

- Ceiling mount
- Back plate covers a standard recessed 4" octagonal outlet box
- Unit can also be installed over a surface mounted "pancake" outlet box
- Outlet box mounting strap supplied

Electrical

- 120 volt NPF electronic ballast
- GX24q-3 based sockets

Labeling

- UL and CUL damp location listed
- Complies with California Title 24 legislation
- Energy Star qualified

