

MODEL SF-717

SteamFast

Home & Away Steam Iron
Dual Voltage (100-127V / 220-240V Selectable)

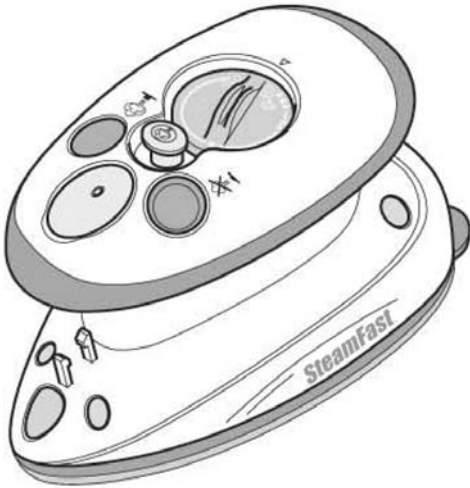

by Top Innovations, Inc.

Please read all instructions before use.

Please visit the **PRODUCT REGISTRATION** page on our Web site and fill out the online form to register your unit for warranty service.

IMPORTANT SAFETY INSTRUCTIONS

READ ALL INSTRUCTIONS BEFORE USE

WARNING: To reduce the risk of fire, electrical shock or injury, the following basic safety precautions should always be followed when using an electrical appliance.

DANGER: Any appliance is electrically live even when switch is off. To reduce risk of death by electrical shock:

1. Always unplug power cord immediately after using.
2. Do not place or store unit where it can fall or be pulled into a sink or tub.
3. Do not place in, or drop into water or other liquid.
4. If unit falls into water, immediately unplug power cord. Do not reach into the water.

WARNING: To reduce risk of burns, electrocution, fire, or injury to persons:

1. Use Home & Away Steam Iron only for its intended purpose as indicated in these instructions.
2. Do not use an extension cord to operate this unit.
3. Before plugging power cord into electrical outlet, be sure that all electrical information on rating label agrees with your power supply.
4. To reduce likelihood of circuit overload, DO NOT operate another high wattage appliance on the same circuit as this unit.
5. To protect against risk of electrical shock, do not immerse unit in water or other liquids. Do not use power cord as handle, allow it to hang over edge of counters, or be crimped or closed in doors.
6. Never yank power cord to disconnect from outlet; instead, grasp plug and pull to disconnect.
7. Do not operate unit with a damaged power cord or if the unit has been dropped or damaged. To avoid risk of electrical shock, do not disassemble unit; take it to a qualified service repair person for examination and repair. Incorrect reassembly can cause a risk of electrical shock when unit is used.
8. Close supervision is required for any appliance being used near children, pets and plants. Do not leave unit unattended while plugged in.

IMPORTANT SAFETY INSTRUCTIONS

9. This unit is not intended for use by persons (including children) with reduced physical, sensory or mental capabilities, or lack of experience and knowledge, unless they have been given supervision or instruction concerning use of the unit by a person responsible for their safety.
10. If Heating Indicator Light does not illuminate when Temperature Control Dial is turned to one of three heat setting, unit is not operating normally. Immediately unplug and have unit serviced by qualified service personnel.
11. Unplug power cord before filling Water Tank with water.
12. Do not use unit where aerosol-based products are being used, or where oxygen is being administered.
13. Unit is only meant to be used with recommended SF-717 accessories. Using other types of attachments may cause damage to unit or injury.
14. When filling Water Tank, only water should be used in unit - other cleaning agents could damage unit or cause injury. Distilled or de-mineralized water is highly recommended, in order to minimize potential build-up of mineral deposits. Do not overfill unit.
15. Do not attempt to use steam function without properly filling Water Tank.
16. To reduce risk of contact with hot water emitting from steam vents, check appliance before each use by positioning it away from body and pressing Steam Button. Do not operate unit if steam vents are blocked.
17. Burns can occur from touching hot metal parts, hot water, or steam. Do not touch Ironing Plate while unit is in use. Do not turn unit upside-down - it may contain hot water.
18. When steaming/ironing any item for the first time, it is recommended that you consult the manufacturer's guidelines for material being steamed. For items in question, test on an inconspicuous area before proceeding.
19. Do not allow power cord to touch hot surfaces (such as Ironing Plate) during use. Wrap cord around base of Hand Grip when storing.
20. Always allow Home & Away Steam Iron to cool completely (at least 30 minutes) before storing. Prop unit upright on Stand when cooling, to avoid heat damage to surfaces.

**SAVE THESE INSTRUCTIONS
FOR HOUSEHOLD USE ONLY**

PRODUCT INFORMATION

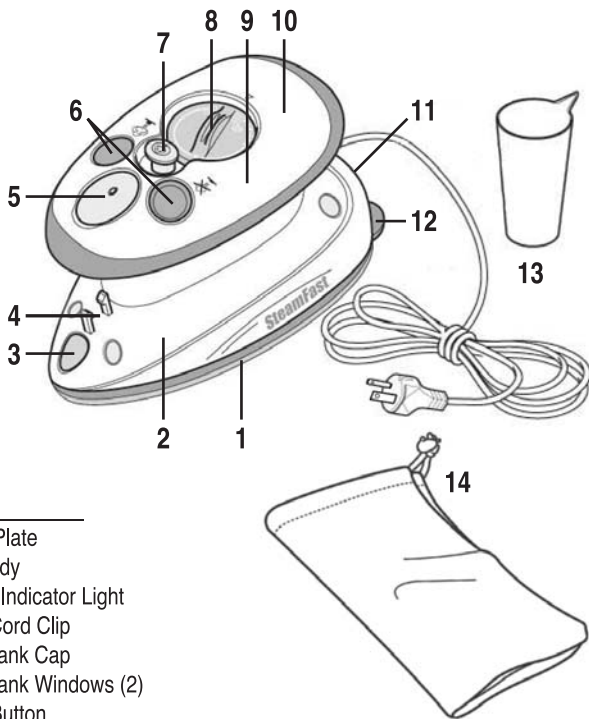

FEATURES

1. Ironing Plate
2. Main Body
3. Heating Indicator Light
4. Power Cord Clip
5. Water Tank Cap
6. Water Tank Windows (2)
7. Steam Button
8. Temperature Control Dial
9. Hand Grip
10. Water Tank (internal)
11. Voltage Selector
12. Stands (2)

ACCESSORIES

13. Measuring Cup
14. Travel Bag

PRODUCT INFORMATION

1. The **Ironing Plate** is the heated, non-stick surface that is used to press fabrics, remove wrinkles and create creases.
2. The **Main Body** contains the unit's internal heating components.
3. The **Heating Indicator Light** illuminates when the Temperature Control Dial is set to one of the three heat settings. **Refer to Page 8 for details.**
4. The **Power Cord Clip** holds the power cord securely when wrapped around the base of the Hand Grip for storage. **Refer to Page 9 for details.**
5. The **Water Tank Cap** covers the Water Tank fill hole. The Water Tank Cap is tethered to the unit, and cannot be completely removed. **Refer to Page 7 for details.**
6. The **Water Tank Windows** let you monitor the level of water in the Water Tank. The unit must be sitting upright to correctly read the water level.
7. The **Steam Button** is pressed to activate the unit's steam function. Locking the Steam Button down disables steam; pressing the Steam Button releases it into the unlocked position, enabling steam. **Refer to Page 8 for details.**
8. The **Temperature Control Dial** is turned to select one the three heat settings, and to turn heating off. **Refer to Page 8 for details.**
9. The **Hand Grip** is ergonomically designed for user comfort. The Hand Grip contains the unit's Water Tank, and the base is specially designed for the power cord to be wrapped around for storage.
10. The **Water Tank**, located inside the Hand Grip, is designed to hold a maximum of 1.1 oz (32 ml.) water. **Refer to Page 7 for details.**
11. The **Voltage Selector** is the recessed switch which is used to set the unit to either 100-127V or 220-240V electrical voltage standards. By default the Voltage Selector is set to 100-127V. **Refer to Page 6 for details.**
12. The **Stands** are the two supports located at the rear of the Main Body. The Stands are designed to support the unit in an upright position when the Ironing Plate is hot, to help prevent damage to surfaces.
13. The **Measuring Cup** is designed to help you easily and consistently fill the Water Tank with the optimum amount of water.
14. The **Travel Bag** is designed to hold the unit and Measuring Cup for more convenient packing and travel.

USING THE HOME & AWAY STEAM IRON

SETTING VOLTAGE

The Home & Away Steam Iron features dual-voltage functionality, which allows it to function correctly in regions with either 100-127V or 220-240V electrical voltage standards. Voltage is set using the Voltage Selector.

IMPORTANT: By default, the Voltage Selector is set to the 100-127V setting. Be sure to select the correct voltage for your location before plugging power cord into an electrical outlet.

To change the voltage setting:

NOTE: These steps assume that Voltage Selector is still set to 110-127V default.

1. Locate Voltage Selector, recessed inside slot at rear of Main Body. Note the white open notch in middle of Voltage Selector (FIGURE 1-A).
2. Find a tool with a fine tip - a pen is ideal.
3. Carefully insert tip of pen into white notch. Slide Voltage Selector to the right, towards 220-240V label (FIGURE 1-B).

IMPORTANT: Be sure that Voltage Selector is moved as far to the right as possible for voltage setting to take effect correctly. Voltage Selector should appear as shown (FIGURE 1-C).

4. Unit is now ready for use in a 220V region. To set unit back to 110V, reverse **STEPS 2 & 3**, this time sliding Voltage Selector as far to the left (towards 100-127V label) as possible.

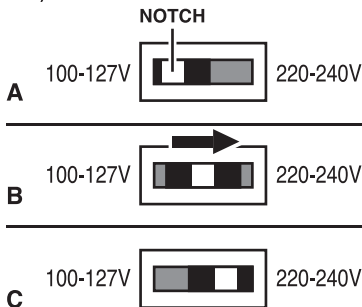

FIGURE 1

USING THE HOME & AWAY STEAM IRON

FILLING WATER TANK (FOR STEAM IRONING)

1. Place unit (Ironing Plate down) on a flat, heat-resistant surface.
2. Fill Measuring Cup with water up to MAX (1.1 oz. / 32 ml.) mark.

NOTE: In order to extend the life of your unit and keep it functioning at it's maximum potential, it is highly recommended that distilled or de-mineralized water be used in Water Tank.

3. Open Water Tank Cap. Pour water from Measuring Cup into Water Tank (FIGURE 2). Close Water Tank Cap.

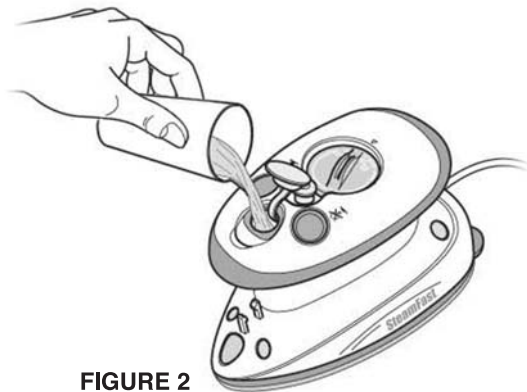

FIGURE 2

While steam-ironing, the Water Tank Windows let you monitor the water level in the Water Tank. When the water level becomes low:

1. Turn off and unplug unit. Allow to cool for at least 5 minutes.
2. Follow **STEPS 1-3** above.
3. Plug power cord back in and resume ironing as usual.

USING THE HOME & AWAY STEAM IRON

OPERATING UNIT

DRY IRONING

IMPORTANT: Make sure Steam Button is locked in lowered position (FIGURE 4-B) before dry ironing. This will prevent any water from accidentally dripping.

1. Plug power cord into a convenient electrical outlet.
2. Turn Temperature Control Dial clockwise so that small arrow (Δ) on Hand Grip (FIGURE 3-A) points to one of three heat settings on Dial (FIGURE 3-B). Heating Indicator Light will illuminate.

NOTE: It is recommended to start with lower temperatures first, as high settings designed for heavy materials can damage delicate fabrics.

3. When Heating Indicator Light turns off, Ironing Plate is heated and ready for use.

NOTE: During use, Heating Indicator Light will cycle on and off as unit works to maintain a constant temperature. You may continue to iron while Light cycles.

STEAM IRONING

1. Plug power cord into a convenient electrical outlet.
2. Turn Temperature Control Dial clockwise as far as possible to set unit to high temperature (MAX ●●●). Heating Indicator Light will illuminate.
3. When Heating Indicator Light turns off, press Steam Button. Button will lock into raised position (FIGURE 4-A), and unit will begin emitting steam from steam vents on Ironing Plate.

NOTE: Unit is designed to steam horizontally. Steam flow will stop whenever unit is in vertical upright position.

4. To stop steam flow, press Steam Button again to lock it into lowered position (FIGURE 4-B).

Once all ironing tasks are finished, immediately turn Temperature Control Dial counter-clockwise until it is set to off (O) position. **Be sure that Steam Button is locked in lowered position** - this will prevent water from accidentally dripping during next use. Prop unit upright on Stands to cool, and refer to **CARE & STORAGE GUIDELINES** on Page 9 for proper cleaning and storage.

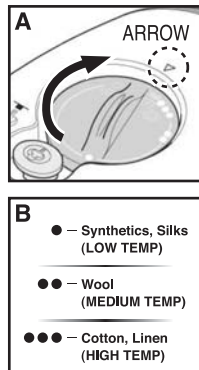

FIGURE 3

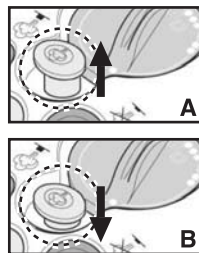

FIGURE 4

PRODUCT INFORMATION

CLEANING & STORAGE

1. Turn Temperature Control Dial to "off" (O) position. Unplug power cord.
2. Prop unit upright on Stands and allow Ironing Plate to cool for 30 minutes.
3. Open Water Tank Cap and drain any remaining water into a sink or tub. Close Cap when finished.
4. Wipe Main Body and Ironing Plate with a soft cloth lightly moistened with water.
 - **DO NOT clean Ironing Plate with detergents or descalers**
 - **DO NOT clean Ironing Plate with abrasive or corrosive products**
 - **DO NOT submerge unit or hold unit under running water.**
5. Wrap power cord around base of Hand Grip and secure end in Power Cord Clip as shown (FIGURE 5). Place unit and Measuring Cup inside Travel bag and store in a cool, dry location.



FIGURE 5

MINERAL BUILD-UP

1. Follow **STEPS 1-3** under **CLEANING & STORAGE** section above; however, leave Water Tank Cap open.
2. Make a mixture of 0.5 oz. distilled water and 0.5 oz. vinegar.
3. Using included Measuring Cup, pour water-vinegar solution into Water Tank. Close Water Tank Cap.
4. Follow normal steam ironing procedure, as outlined on Page 8. Allow unit to steam out full contents of Water Tank. When finished, lock Steam Button in lowered position and unplug unit.
5. Allow to cool for 5 minutes, then refill Water Tank with fresh distilled water. Repeat **STEP 4** until vinegar odor dissipates.
6. Store unit as normal.

SUPPORT / PRODUCT SPECIFICATIONS

CUSTOMER SUPPORT

For problems with your Home & Away Steam Iron, please direct all inquiries to our Customer Support services through our Web site, www.SteamFast.com, on the Contact Us Web page.

If you do not have internet access, you may also contact our Customer Support Department directly by telephone, at **1-800-711-6617** or **1-816-584-9700**, ext. **130** or **131**.

NOTE: In order for our customer service representatives to help you as quickly and efficiently as possible, please have the following information ready before calling:

- Purchase information (where and when you purchased this product)
- Copy of purchase receipt / proof of purchase
- Product Serial Number

PRODUCT SPECIFICATIONS

VOLTAGE: 100-127V / 220-240V

WATTAGE: 260W - 420W / 343W - 408W

AMPERAGE: 3.0A

WATER CAPACITY: 1.1 OZ. (32 ML.)

HEATING TIME: 15 SEC. (APPROXIMATE)

TEMPERATURE RANGE: 140°F - 428°F (60°C - 220°C)

UNIT WEIGHT: 0.93 LBS. (0.42 KGS.)

UNIT SIZE: 5.3" (13.5 CM.) x 2.9" (7.6 CM.) x 3.1" (7.9 CM.)

WARRANTY INFORMATION

Before returning any product for any reason, you must call or e-mail Top Innovations Warranty Service at (800) 711-6617 or customerservice@topinnovations.com to obtain a Return Authorization Number.

30-DAY MONEY BACK POLICY

If this item does not meet your expectations, it may be returned within 30 days of the date of purchase for either a replacement or full refund of the purchase price less any shipping charges. In some circumstances, an additional restocking fee will apply.

ONE YEAR LIMITED WARRANTY

(If outside USA, additional shipping charges may apply)

Top Innovations, Inc., warrants this product to be free from defects in material and workmanship for a period of one (1) year from the date of purchase. This warranty does not cover damage caused by misuse, negligence, use by improper current or voltage, commercial use, use contrary to operating instructions or disassembly, repair or alteration by any person other than Top Innovations, Inc. Warranty Service Department.

Top Innovations, Inc., will repair or replace at its option. This warranty gives you specific legal rights and may have other rights, which may vary from state to state.

Should there be any missing or defective parts or accessories, please contact Customer Support. In most cases, it is not necessary to return the entire unit. We can ship most replacement parts directly to your home.

Upon expiration of your one (1) year limited warranty, you will be advised of the cost of repair before any servicing is done. You must have a Return Authorization Number. For non-warranty service, please enclose a check for the amount required. Or, you may pay by money order, Visa, MasterCard, AmEx or Discover credit card.

If you need to request warranty service, or have any questions about coverage under this warranty, please visit the Warranty Service Request page on our Web site, www.SteamFast.com. You may also e-mail customerservice@topinnovations.com, or phone (800) 711-6617, ext 130 or 131.

Please have your product serial number ready before contacting Warranty Service Department. The serial number is located on the back or bottom of your unit.

Performance of any obligation of this Warranty, or 30-Day Money Back Policy, may be obtained by:

1. Call (800) 711-6617 or e-mail customerservice@topinnovations.com for a Return Authorization Number before returning your unit. Failure to obtain a Return Authorization Number will cause a delay in service.
2. Include a copy of purchase receipt.
3. Box the item securely, in its original packaging if available. Include original packing materials and accessories unless advised otherwise by a Customer Service agent.
4. Include your name, address, telephone number, and Return Authorization Number on returned package.

Send unit postage/freight-prepaid (Top Innovations does not accept "collect" or COD returns) to:

Top Innovations, Inc.
Warranty Service Department
6655 Troost Ave.
Kansas City, MO 64131

Call Top Innovations, Inc., Customer Service at (800) 711-6617, or (816) 584-9700 if you have any questions about the procedures described above.

SteamFast[®]

Top Innovations, Inc.

6655 Troost Ave. • Kansas City, MO 64131

TEL: (800) 711-6617 / (816) 584-9700

FAX: (816) 584-9066

www.SteamFast.com



PRINTED IN CHINA