

# Vinotemp®

A PROUD HERITAGE OF EXPERIENCE & QUALITY

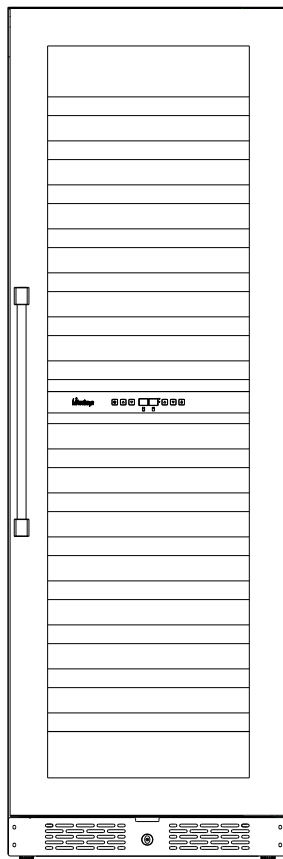

## WINE COOLER

VT-24PR125

OWNER'S MANUAL



WWW.VINOTEMP.COM



## YOUR WINE CELLAR

This unit can be used for Storage and/or Service. The unit has a glass door and soft interior light that you can use to store your wine.

### Serving Wines

Storing wines at the proper temperature is important. To preserve them as long as possible wine should be stored at approximately 55° Fahrenheit. However, the chart below suggests the optimal drinking temperature for the different styles of wine.

°C	°F	Wine Style
19	66	Armagnac, Brandy, Cognac
18	64	Full Bodied Red Wines, Shiraz
17	62	Tawny Port
15	59	Medium Bodied Red Wines
14	57	Amontillado Sherry
13	55	Light Bodied Red Wines
12	54	Full Bodied White Wines
11	52	Medium Bodied White Wines
10	50	Rosé, Light Bodied White Wines
9	48	Vintage Sparkling
8	46	Fino Sherry
7	45	Non Vintage Sparkling

## **General Operating Instructions**

Remove all external and internal packaging from your appliance. Be sure that all parts have been included before discarding any packaging materials. You may want to keep the box and packing materials for use at a later date.

Upon receipt and inspection of unit, the supply cord must be replaced if it is damaged. Contact our customer service at 1-800-777-8466 or [info@vinotemp.com](mailto:info@vinotemp.com).

**READ ALL INSTRUCTIONS BEFORE USING THIS APPLIANCE**  
**-Save these instructions-**

**To register your product, visit:**  
**<http://www.vinotemp.com/Warranty.aspx>**  
**Register your warranty within 10 days of receiving the unit.**  
**Please be sure to retain your proof of purchase.**

### **State of California Proposition 65 Warnings:**

**WARNING:** This product can expose you to chemicals including BPA, Styrene, Nickel (Metallic) as well as some other products listed in the Prop 65 list used in making our appliances, which is known to the State of California to cause cancer and reproductive harm.

For more information go to [www.P65Warnings.ca.gov](http://www.P65Warnings.ca.gov)

# TABLE OF CONTENTS

IMPORTANT SAFETY INSTRUCTIONS .....	6
ELECTRICAL CONNECTION.....	7
PARTS AND SPECIFICATIONS.....	8
INSTALLATION .....	9
OPERATING YOUR APPLIANCE .....	12
CARE AND MAINTENANCE.....	16
TROUBLESHOOTING .....	18
TERMS OF SALE AND WARRANTY.....	20

## IMPORTANT SAFETY INSTRUCTIONS



**To reduce the risk of fire, electrical shock or injury when using your appliance, follow these basic precautions:**

- Do not operate this or any other appliance with a damaged cord.
- Do not operate if housing is removed or damaged.
- Exercise caution and use reasonable supervision when appliance is used near children. Never allow children to operate, play with or crawl inside the appliance. Keep packing materials away from children.
- Before performing any maintenance or cleaning, ensure that the unit is unplugged or that the power line is disconnected.
- Do not clean appliance with flammable fluids. Do not store or use gasoline or other flammable vapors and liquids in the vicinity of this or any other appliance. The fumes can create a fire hazard or explosion.
- Exercise caution when moving and installing the unit. The cooler is heavy and may require two or more people when moving the unit to prevent strain or injury.
- To ensure proper ventilation for your appliance, the front of the unit must be completely unobstructed. Choose a well-ventilated area with temperatures above 44°F (7°C) and below 90°F (32°C).
- Locate the unit away from direct sunlight and sources of heat (stove, heater, radiator, etc). This unit is intended for indoor use only and must be installed in an area protected from the elements.
- Place the appliance on a solid, level surface.
- Do not attempt to repair or replace any part of your appliance unless it is specifically recommended in this manual. All other servicing should be referred to a qualified technician.
- Connect to properly polarized outlets only. It is recommended that a separate circuit, serving only your appliance be provided. Use receptacles that cannot be turned off by a switch or pull chain. Be sure that the plug is fully inserted into the receptacle.
- To protect against electric shock, do not immerse appliance, plug or cord in water or other liquids. Avoid locating the unit in moist areas.
- This appliance is designed to be built-in (fully-recessed) or freestanding for indoor use only.
- Do not use this appliance for other than its intended purpose.
- Do not operate the unit with wet hands, while standing on a wet surface or while standing in water.
- Do not use solvent-based cleaning agents or abrasives on the interior of the cooler. These cleaners may damage or discolor the interior.
- Keep fingers out of pinch point areas and be careful when closing doors if children are around.
- When disposing of refrigerated appliances, special handling is often required. It is the consumer's responsibility to comply with federal and local regulations when disposing of this product.
- This appliance is CFC- and HFC-free and contains small quantities of Isobutane (R600a) which is environmentally friendly, but flammable. It does not damage the ozone layer, nor does it increase the greenhouse effect. Care must be taken during transportation and setting up of the appliance that no parts of the cooling system are damaged. Leaking coolant can ignite and may damage the eyes.

In the event of any damage:

- Avoid open flames and anything which creates a spark,
- Disconnect from the power supply,
- Air the room in which the appliance is located for several minutes and
- Contact the Service Department for advice.
- The more coolant there is in an appliance, the larger the room it should be installed in. In the event of a leakage, if the appliance is in a small room, there is the danger of combustible gases building up. For every ounce of coolant at least 325 cubic feet of room space is required. The amount of coolant in the appliance is stated on the data plate inside the appliance. It is hazardous for anyone other than an Authorized Service Person to carry out servicing or repairs to this appliance.
- Take serious care when handling, moving and using the appliance to avoid either damaging the refrigerant tubing or increasing the risk of a leak.
- Replacing component parts and servicing shall be done by factory authorized service personnel, so as to minimize the risk of possible ignition due to incorrect parts or improper service.
- **WARNING:** Risk of child entrapment and suffocation. Before you throw away this or an old unit, take off the door. Leave the shelves in place, so that children may not easily climb inside.

## - SAVE THESE INSTRUCTIONS -

## ELECTRICAL CONNECTION

	<p><b>Improper use of the grounded plug can result in the risk of electrical shock. If the power cord is damaged, frayed or shows cracks or abrasions across its length, have it replaced at an authorized service center.</b></p>
--	--

For your protection, this unit is equipped with a 3-conductor cord set that has a molded 3-prong grounding-type plug, and should be used in combination with a properly connected grounding-type outlet.

- Do not under any circumstances cut or remove the third ground prong from the power cord supplied. For personal safety, this appliance must be properly grounded.
- The cord should be secured behind the unit and not left exposed or dangling to prevent accidental injury.
- A standard electrical supply (115/120V AC only, 60Hz, 15A), properly grounded in accordance with the National Electrical Code and local codes and ordinances, is required.
- Never unplug the unit by pulling the power cord. To disconnect the appliance, always grip the plug firmly and pull straight out from the wall outlet. When moving the unit, be careful not to damage the power cord.
- The unit should always be plugged into its own individual electrical outlet with a voltage rating that matches the rating label on the unit.

### Extension Cord

**CAUTION:** It is strongly recommended that you do not use an adapter or an extension cord with this unit.

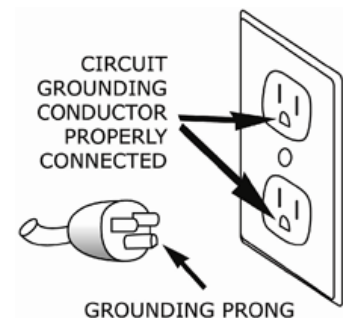

## PARTS AND SPECIFICATIONS

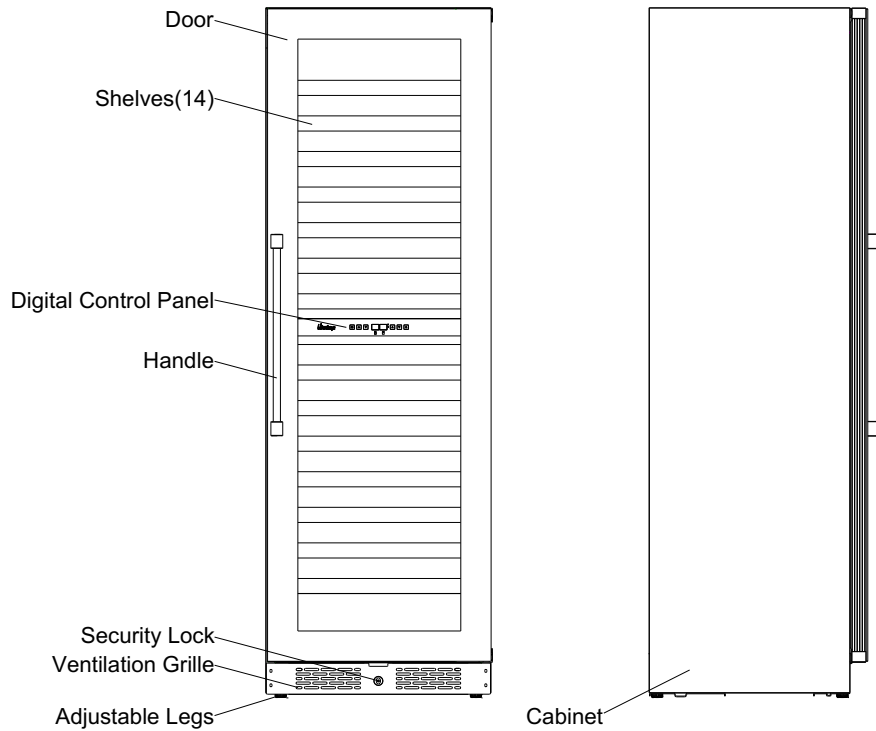

Model No.	VT-24PR125
Voltage	AC 115V
Frequency	60 Hz
Ambient Temperature Range	44°- 90°F
Control Temperature Range	41°- 68°F
Refrigerant	R600a/1.77oz
Power Consumption	245 kWh/Year
Input Power	160W
Volume	11.94 Cu.Ft.
Net Weight	214 lbs
Gross Weight	240 lbs
Dimensions (W x D x H)	23½" x 24¼" x 72½"
Box Dimensions (W x D x H)	26" x 24¾" x 79⅝"



## INSTALLATION

- Remove all packing material before using your appliance.
- **IMPORTANT:** Before connecting the unit to a power source, let it stand upright for approximately 24 hours. This will reduce the possibility of a malfunction in the cooling system from handling during transportation.
- Clean the interior surface with lukewarm water and a soft cloth.
- This unit is designed for freestanding or built in installation and indoor use only. Position the unit in a dry and well-ventilated place. Avoid placing the unit near any source of heat or moisture, or in direct sunlight. Do NOT install the unit in a location with an ambient temperature that will fall below 44°F.
- For freestanding installation, 5 inches of space between the back and sides of the unit are suggested, which allows the proper air circulation to cool the compressor and condenser for energy saving. Even for built-in installation, it is a must to keep ¼" space on each side and at the top to ensure proper service access and ventilation. And the air vent at the front of the appliance must never be covered or blocked in any way.
- Place the unit on a level surface strong enough to support it when it is fully loaded. To level the appliance, adjust the front leveling legs at the bottom of the appliance.
- For best performance it is recommended that you install the appliance in a location with an ambient temperature between 72°-78°F. If the ambient temperature is above or below recommended temperatures, the performance of the unit may be affected.

### REVERSING THE DOOR SWING OF YOUR APPLIANCE

**WARNING**

Use extreme caution with the articulated hinges. The hinge is self-closing and many pinch points exist prior to built-in installation.

This unit has the capability of the door opening from either the left or right side. The unit is delivered to you with the door opening from the left side. Should you desire to reverse the opening direction, please follow the reversal instructions shown as the below.

**NOTE:** All parts removed must be saved to allow the door swing to be reversed.

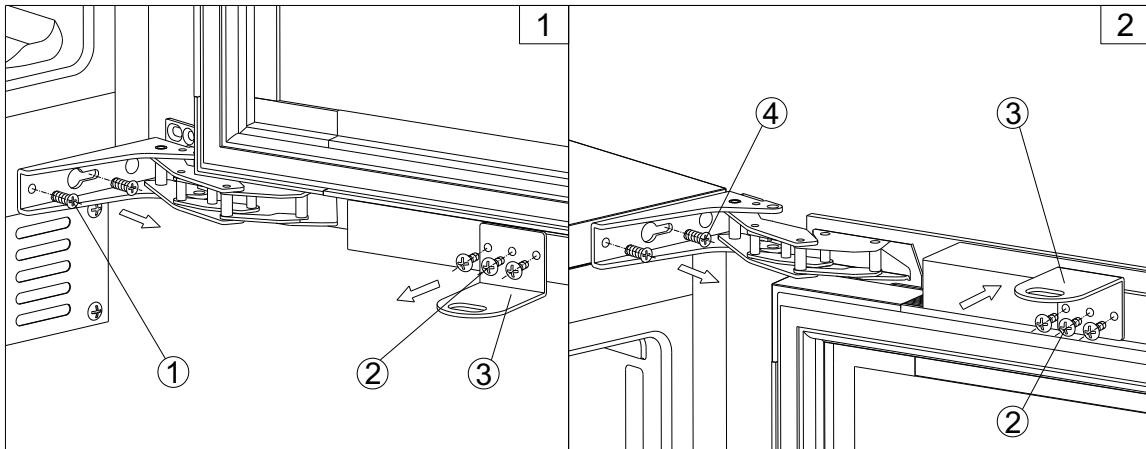

1. Remove the cover cap and then remove the glass door by unscrewing the four screws (1) and (4). Be careful to hold the glass door firmly after removing the screws and place it on a padded surface to avoid the risk of damage.
2. Unscrew and transfer the lock catch (3) to the opposite side.
3. Rotate the glass door 180° and refit the glass door to the opposite side. Then screw and tighten it after the door is leveled.

## ANTI-TIP BRACKET INSTALLATION

To reduce the risk of tipping the unit by abnormal usage or improper loading, the appliance must be secured by properly installing the anti-tip device packed with the appliance.

- Place the anti-tip bracket on the floor as shown in the figure. An anti-tip bracket must be installed at the left side.
- Mark the locations of the 4 holes of the anti-tip bracket on the floor.
- Use a 5/16" masonry drill bit and insert plastic anchors.
- Secure bracket to floor using screws.
- Slide appliance into position and make sure the leg engages the anti-tip bracket.

**NOTE:** If the unit is relocated, the bracket must be removed and installed in the new location.

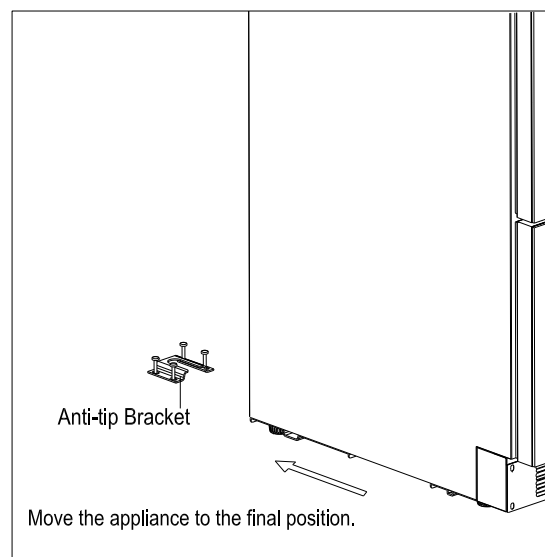
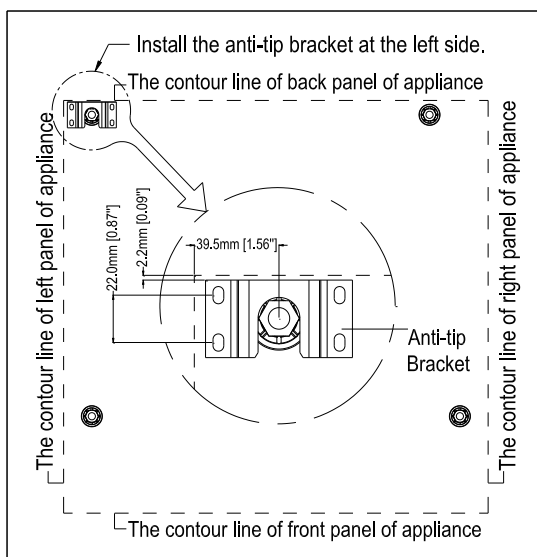

# OVERLAY PANEL INSTALLATION INSTRUCTIONS

## Door Panel Preparation

Prepare the overlay panel to the dimensions shown below. Then attach the handle to the overlay panel by using the flat head screws and drive the screws flush with the panel.

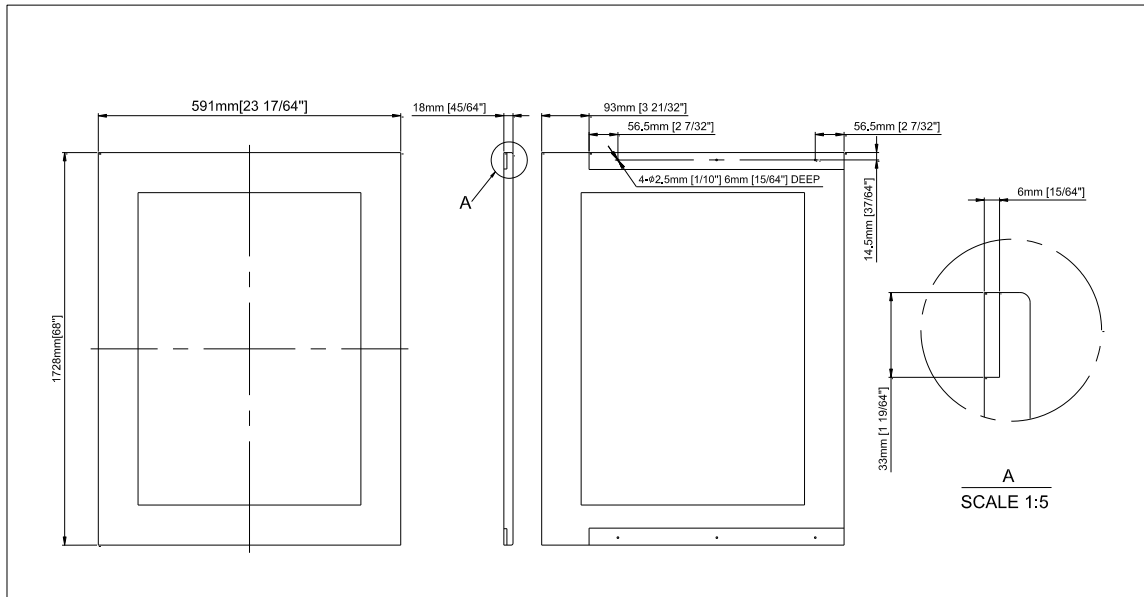

## **NOTE:**

1. Weight of the overlay panel should not exceed 35 pounds (16 kilograms).
2. It is important to ensure that all drilled holes are drilled to the correct depth in order to avoid splits in the wood when hardware is installed.
3. Drill the handle installation holes in the overlay panel according to the handle you are planning to use. If reusing the handles came with the unit, drill two holes with holes distance 490mm (19-19/64") and diameter 5mm (3/16") in the overlay panel.

## Door Panel Installation

1. Attach two provided mounting brackets (2) to the prepared wood overlay panel (3) by using 4/6 wood screws #10x3/8" (ST4x10) Type AB Philips (1). (Fig. 1)
2. Gently slide the overlay panel on the glass door (4). (Fig. 2)
3. Fix the wood overlay panel (3) on the glass door by using 4 screws #10x3/8" (ST4x10) Type AB Philips (5).

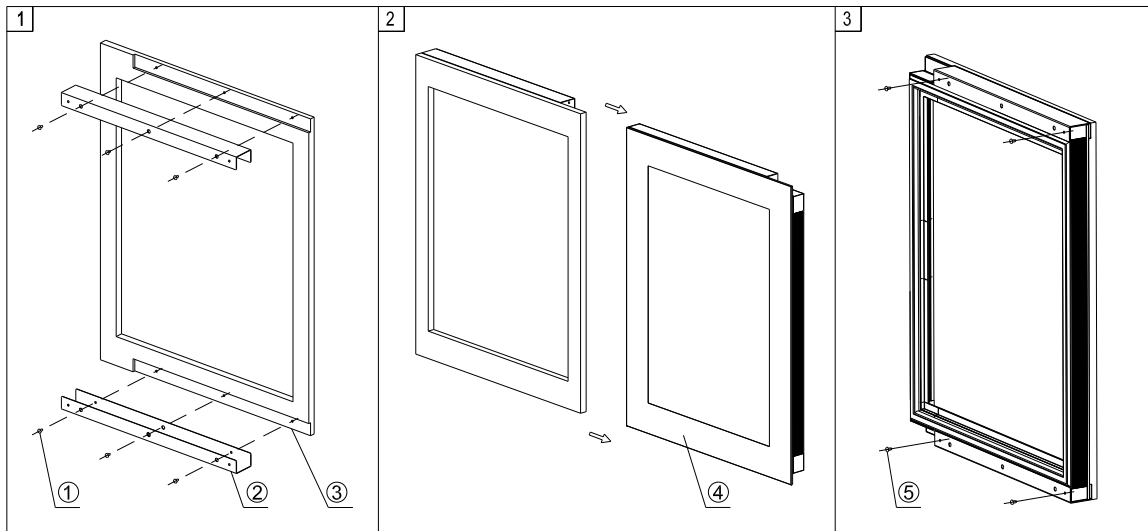

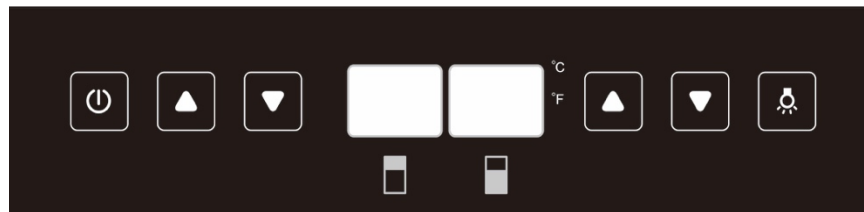

## OPERATING YOUR APPLIANCE

### CONTROLS



#### **ON/OFF Power**

To turn the appliance off, press and hold the  key for 5 seconds until temperature display goes out. To turn the appliance on, press and hold the  key for 1 second until temperature display lights up.

**NOTE:** Pressing the POWER key once can switch off the audible alarm when the alarm is on.

#### **LIGHT**

Turn the interior light ON/OFF.

#### **UP**

Used to increase (warm) the set temperature by 1°C/1°F.

#### **DOWN**

Used to decrease (cool) the set temperature by 1°C/1°F.

#### **°F/°C Selector**

Select the temperature display setting in Fahrenheit or Celsius degree. To change the temperature from Fahrenheit to Celsius or from Celsius to Fahrenheit, press and hold the **LIGHT** key for 5 seconds.

## SETTING THE TEMPERATURE

- The unit has two separate temperature zones. The temperature of both zones can be set between 5°C and 20°C (41°F and 68°F). It can be used as a wine maturing cabinet or a wine serving cabinet. For maturing wine, the recommended temperature setting ranges of both zones should be between 11°C and 14°C (52°F and 57°F). For serving wine, the recommended temperature setting range of UPPER zone should be between 5°C and 10°C (41°F and 50°F) which is ideal for serving champagne & white wine and the recommended temperature setting range of LOWER zone should be between 15°C and 20°C (58°F and 68°F) which is ideal for serving red wine.
- When the unit is plugged in for the first time, the unit will power up automatically to the preset defaults. The preset temperature at the factory for UPPER temperature zone is 8°C (46°F) and for LOWER temperature zone is 12°C (54°F).
- You can press the left side **UP** and **DOWN** keys to control the internal temperature of the UPPER temperature zone and press the right side **UP** and **DOWN** keys to control the internal temperature of the LOWER temperature zone. When you press either key at the first time, the display will show the last temperature set previously.
- **IMPORTANT:** The temperature set for the LOWER temperature zone must always be just as high as or higher than that in the UPPER temperature zone. For optimal performance, the set temperature of the two zones should differ by at least 4°C (7°F).
- The temperature that you desire to set will increase 1°C or 1°F if you press the **UP** key once, on the contrary the temperature will decrease 1°C or 1°F if you press the **DOWN** key once. The display flashes while you make the setting.
- After the temperature has been set, the display shows the current inner temperature of the particular temperature zone.
- To view the set temperature at any time, press the **UP** or **DOWN** key, the set temperature will temporarily flash in the display for 5 seconds. Then the display shows the current inner temperature again.

## INTERIOR LIGHT

- The interior light makes it easy to view your items. Touching the LIGHT mark toggles between 2 modes of operation for the internal lights: functional (default) mode and showcase mode. If you are in functional (default) mode, the lights will turn on only when the door is open. If you are in showcase mode, the lights will be on whether or not the door is open.

**NOTE:** When using the unit for the first time or after a long period of inactivity, there may be a variance of a few degrees between the selected temperature and the temperature indicated on the LED readout. This is normal due to the length of inactivity, and will correct itself after the unit is run for a few hours. If the unit is unplugged, has lost power or is turned off, wait 3 to 5 minutes before restarting the unit. The unit will not restart before this time delay.

## DYNAMIC COOLING/SILENT MODES

The Dynamic Cooling feature enables the temperature to be distributed evenly around the interior so you can store all your goods under exactly the same excellent conditions.

In the Dynamic Cooling mode, the interior fan circulates the inside air evenly even when the set temperature is reached. Dynamic Cooling mode is **NOT** the factory preset mode because of creating noises and more energy consumption. To change to Dynamic Cooling mode, touch and hold the **DOWN** key for approximately five seconds. The appliance will beep five times to confirm Dynamic Cooling mode is on. To change back to default (Silent) mode, touch and hold the **UP** key for approximately five seconds. The appliance will beep three times to confirm default (Silent) mode is on.

## SABBATH MODE

Sabbath mode is available for the observance of certain religious holidays. This mode turns off the displays, interior light and audible alarms and prevents them from turning on again. Normal cooling operations will still take place.

To initiate Sabbath mode, press the **POWER** and **LIGHT** keys at the same time for at least 5 seconds. The indicator light will flash four times and confirm the Sabbath mode is ON. Sabbath mode can be canceled by repeating the above process. The Sabbath Mode will automatically turn off after 96 hours.

## TEMPERATURE MEMORY FUNCTION

- In the event of a power interruption (power surge, breaker switch, etc.), the unit can remember the previous temperature settings, and when the power is recovered, the cabinet temperature will return to the same setting temperature as before the power went off.

## TEMPERATURE ALARM / DOOR ALARM

- An audible alarm sounds if the storage temperature is not cold enough. The temperature display flashes at the same time.
- The cause of the temperature being too high may be:
  - Warm fresh food was placed inside
  - Too much warm ambient air flowed in when rearranging and removing food
  - Power failure for some time
  - The appliance is faulty
- The audible alarm is automatically silenced and the temperature display stops flashing when the temperature is sufficiently cold again.
- If the door has been left open for more than 60 seconds, the alarm will sound. Pressing the **POWER** key once can switch off the audible alarm.

## STORING WINE

You can place 8 standard bottles on the top shelves and 6 standard bottles on the bottom rack. Approximate wine cooler capacity is 126 bottles.

**Note:** Bottle capacities are approximate maximums when storing traditional Bordeaux 750 ML bottles and may include bulk storage. Many bottles differ in size and dimensions. As such, the actual number of bottles you may be able to store may vary.

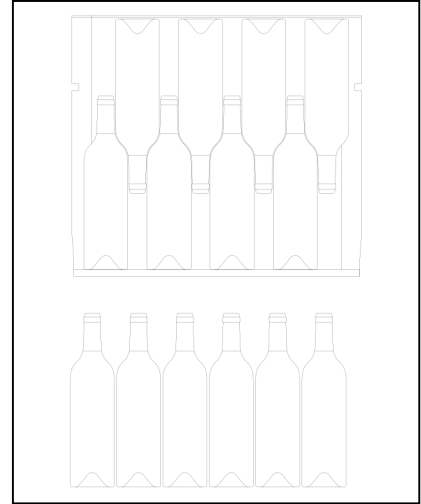

## SHELVES

To prevent damaging the door gasket, make sure to have the door all the way open when pulling the shelves out of the rail compartment.

- For easy access to the stored bottles, you can pull the shelf fully out of the rail compartment.
- To remove a shelf, extend the shelf out of the rail compartment until it stops and remove all bottles from the shelf. Then lift the shelf front straight up and then grasp the slides (2) and push the shelf (1) straight inward to release the shelf from the slides. In order to replace the shelf, repeat this procedure in reverse.

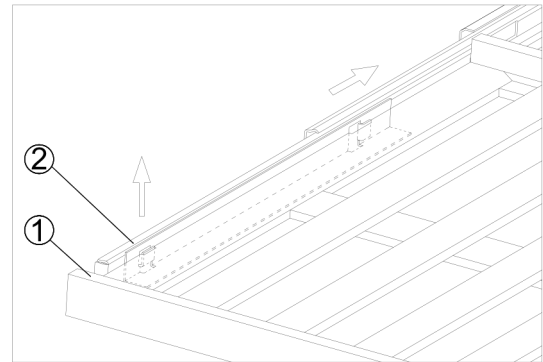

## DOOR LOCK

The unit comes with a lock and key combination. The keys are located inside the plastic bag containing the Owner's Manual. To unlock the door, insert the key into the lock and turn it counter-clockwise. To lock the door, insert the key and turn it clockwise, ensuring that the metal pin is fully engaged.

## DEFROSTING

- The unit defrosts automatically in normal operating conditions.
- The evaporator behind the rear wall of the unit defrosts automatically. The condensate collects in the drainage channel behind the rear wall of the unit, and flows through the drainage hole into the drip tray by the compressor where it evaporates.
- However, frost may accumulate on the evaporator if the unit is repeatedly opened in a high heat or high humidity location. If this frost pattern does not clear within 24 hours, your unit will require manual defrosting.

# CARE AND MAINTENANCE

## CLEANING YOUR APPLIANCE

**IMPORTANT:** Always unplug the unit before cleaning or performing maintenance. Never use harsh cleansers or scouring pads to clean any part of the unit.

- Turn off the power, unplug the appliance, and remove all items including shelves.
- Wash the inside surfaces with a warm water and baking soda solution. The solution should be about 2 tablespoons of baking soda to a quart of water.
- Wash the shelves with a mild detergent solution.
- Wring excess water out of the sponge or cloth before cleaning control panels or any electrical parts.
- Wash the outside cabinet with warm water and mild liquid detergent. Rinse well and wipe dry with a clean soft cloth.
- Use an approved stainless steel cleaner to clean the door. Do not use steel wool or a steel brush on the stainless steel.

## POWER FAILURE

Most power failures are corrected within a few hours and should not affect the temperature of your appliance. If the power is off for an extended period of time, proper steps should be taken to protect your contents.

## INACTIVITY

If the unit will not be used for a period of less than three weeks, leave the unit operating. If the period of inactivity is several months, remove all items and turn the unit off. Clean and dry the interior thoroughly. Leave the door open slightly to prevent any possible moisture build-up.

## MOVING YOUR APPLIANCE

Before moving your unit, first be sure to remove all items from the unit.

- Securely tape down any loose items, such as shelves, inside the unit.
- Turn the adjustable leg up to the base to avoid damage.
- Tape the door shut.
- Ensure that the unit stays securely in the upright position during transportation. Protect the outside of the appliance with a blanket or similar item.

## ENERGY SAVING TIPS

- The appliance should be located in the coolest area of the room or outdoor location, away from heat producing appliances and out of direct sunlight.
- Ensure that the unit is adequately ventilated. Never cover air vents. Clean dust and dirt from the condenser at regular intervals.
- Do not keep the door open any longer than necessary.
- Store the content in an organized way.
- To allow air to circulate, do not overfill the appliance
- Unit shelves and storage bins should not be lined with aluminum foil, wax paper, or paper towels. Liners interfere with cold air circulation, making the unit less efficient.





**CAUTION:** Failure to unplug the appliance could result in electrical shock or personal injury.

## PROBLEMS WITH YOUR APPLIANCE

Most common problems can be solved easily, saving you the cost of a possible service call. Try the following suggestions to see if you can solve the problem before contacting Vinotemp at [info@vinotemp.com](mailto:info@vinotemp.com).

### TROUBLESHOOTING

PROBLEM	POSSIBLE CAUSE	REMEDY
Appliance does not operate.	<ul style="list-style-type: none"> <li>• Appliance is not connected to a power supply.</li> <li>• The appliance is turned off.</li> <li>• Tripped circuit breaker or a blown fuse.</li> </ul>	<ul style="list-style-type: none"> <li>• Connect the appliance.</li> <li>• Switch on the appliance.</li> <li>• Switch on circuit breaker or replace fuse.</li> </ul>
Appliance is not cold enough.	<ul style="list-style-type: none"> <li>• The temperature is not set correctly.</li> <li>• The ambient temperature could require a lower temperature setting.</li> <li>• The door was opened too often.</li> <li>• The door was not closed completely.</li> <li>• Door does not create an airtight seal.</li> <li>• The condenser is too dirty.</li> <li>• The ventilation opening is blocked or too dusty.</li> </ul>	<ul style="list-style-type: none"> <li>• Check the set temperature.</li> <li>• Set a lower temperature.</li> <li>• Do not open the door more often than necessary.</li> <li>• Close door properly.</li> <li>• Check the door seal and clean or replace.</li> <li>• Clean the condenser when necessary.</li> <li>• Clear the obstructions and clean the dust.</li> </ul>
Appliance turns itself on and off frequently.	<ul style="list-style-type: none"> <li>• The room temperature is higher than average.</li> <li>• A large amount of food has been added to the unit.</li> <li>• The door is open too often.</li> <li>• The door is not closed completely.</li> <li>• The door gasket does not seal properly.</li> </ul>	<ul style="list-style-type: none"> <li>• Put the appliance in a cooler place.</li> <li>• Leave the appliance to work for a while until the set temperature has been reached.</li> <li>• Do not open the door more often than necessary.</li> <li>• Close door properly.</li> <li>• Check the door seal and clean or replace.</li> </ul>
The light does not work.	<ul style="list-style-type: none"> <li>• Appliance is not connected to a power supply.</li> <li>• Tripped circuit breaker or a blown fuse.</li> <li>• The light was switched off on the control panel.</li> </ul>	<ul style="list-style-type: none"> <li>• Connect the appliance.</li> <li>• Switch on circuit breaker or replace fuse.</li> <li>• Switch on the light.</li> </ul>
Vibrations	<ul style="list-style-type: none"> <li>• The appliance is not properly level.</li> </ul>	<ul style="list-style-type: none"> <li>• Level the appliance with the adjustable feet.</li> </ul>
The appliance seems to make too much noise.	<ul style="list-style-type: none"> <li>• There is a rattling noise.</li> <li>• There are gurgling sounds.</li> </ul>	<ul style="list-style-type: none"> <li>• This noise may be caused by the internal flow of the refrigerant. This is normal.</li> <li>• As each cycle ends, these sounds may be caused by the flow of refrigerant in the appliance.</li> </ul>

	<ul style="list-style-type: none"> <li>• There are popping and cracking noises.</li> <li>• The appliance is not properly leveled.</li> </ul>	<ul style="list-style-type: none"> <li>• These sounds are usually caused by internal temperature fluctuations. It is due to the contraction and expansion of the interior walls.</li> <li>• Level the appliance with the adjustable feet.</li> </ul>
The door will not close properly.	<ul style="list-style-type: none"> <li>• The appliance is not properly level.</li> <li>• The door was reversed and not properly installed.</li> <li>• The gasket is dirty.</li> <li>• The shelves are out of position.</li> </ul>	<ul style="list-style-type: none"> <li>• Level the appliance with the adjustable feet.</li> <li>• Check the door hinge and reassemble correctly.</li> <li>• Clean the door gasket.</li> <li>• Check the shelves and refit correctly.</li> </ul>
Display "E1", "E2" or "E7".	<ul style="list-style-type: none"> <li>• "E1" or "E2" indicates the air temperature sensor has failed.</li> <li>• "E7" indicates a door switch failure.</li> </ul>	<ul style="list-style-type: none"> <li>• Call for service.</li> </ul>
The alarm sounds and the temperature display flashes.	<p>Has the appliance door been open for longer than 60 seconds? If not, then the temperature has risen higher or fallen lower than the temperature that has been set. This could be due to:</p> <ul style="list-style-type: none"> <li>• The appliance door being opened too often.</li> <li>• The ventilation opening being covered or too dusty.</li> <li>• A lengthy interruption to the power supply.</li> <li>• A large amount of bottles has been added to the unit.</li> </ul>	<p>If yes, close the door.</p> <ul style="list-style-type: none"> <li>• Do not open the door more often than necessary.</li> <li>• Clear the obstructions and clean the dust.</li> <li>• Leave the appliance to work for a while until the set temperature has been reached.</li> </ul>
The icon "--" is lit and flashing in the temperature display.	<ul style="list-style-type: none"> <li>• The display temperature is out of range.</li> </ul>	<ul style="list-style-type: none"> <li>• Only temperatures within the range 0~99°F/-9~37°C can be displayed. If the temperature is not within this range, the icon "--" will be displayed instead. This is normal.</li> </ul>

# TERMS OF SALE AND WARRANTY

Vinotemp International Corp. ("Seller") and the person or entity that acquires these goods from Seller ("Purchaser") hereby fully agree to the following terms and conditions of the sale: **Shipping** fees are the responsibility of the Purchaser whether freight prepaid or freight collect. Seller assumes responsibility for the goods sold to the Purchaser until the goods have reached Purchaser's delivery address (FOB Destination) and the delivery receipt is signed clear. Seller is not responsible for the carrier's late delivery, missed delivery, unpaved roads, remote locations, stairs, elevators, narrow door openings and other such issues in attempting to fit or deliver the goods into the Purchaser's location. Delivery to remote locations may require additional fees. Remote location may be defined at the discretion of the carrier as more or less than 50 miles from the nearest major city. Purchaser assumes all responsibility for additional costs related to freight such as access, measurement, installation, hookup, wiring, moving and storage of the goods, flight of stairs, carrier's inability to safely and/or adequately deliver, inability to use the building elevator to lift the goods, narrow openings, along with any additional costs to deliver or redeliver the product properly. Make sure to review access to the property and size of the product ordered. The transportation of all goods is subject to the terms and conditions which the carrier imposes on Purchaser. Installation is the responsibility of the Purchaser. If white glove delivery was ordered and cannot be performed properly, or access is hindered in any way, Purchaser agrees to accept delivery curbside (delivery service cannot be refunded). If Purchaser will-calls or pays for their own freight responsibility transfers to the Purchaser when the Purchaser or Purchasers freight company picks up the unit from Seller. Freight quoted are either curbside, threshold or white glove. Standard white glove delivery is main floor, easy access and NO STAIRS, Doors, aligned feet attached (if necessary) and removal of packaging, additional fees for additional requests. Each service has a different rate and will require additional fees. If freight is not charged (Free Shipping or Freight Included) and the order is cancelled after shipping, a freight charge of 25% of the cost of the unit, each direction will be charged. Item swap outs are arranged as curbside delivery and pickup unless noted otherwise. There is no white glove service for returns. Approved returns must have original and/or proper packaging. Swapouts (Delivery and Pick up are at the same time) Original unit must be packed and ready for carrier pick up at time of delivery of new unit. Packaging of old unit must be adequate for shipping, not oversized or on a pallet if unit was not originally delivered on a pallet. Carrier will not drop off new unit if the original unit is not ready. If the carrier has to make a second attempt, customer will be subject to additional charges for the attempted delivery and for any packaging issues. Deliveries include ONE attempt by the shipping company to deliver the product to the consumer. If for any reason the customer is unavailable to accept the order and the product is undeliverable under any circumstances, the customer will be responsible for any extra shipping and handling charges. We are a manufacturer not a shipping company, deliveries are done by a third party service. Email us at [info@vinotemp.com](mailto:info@vinotemp.com) for a quote or any additional information. Freight discussed is Continental USA (excluding Alaska, Puerto Rico, Hawaii), cost is additional please email [info@vinotemp.com](mailto:info@vinotemp.com) for a quote.

California **Proposition 65** Warning: The products sold on this ecommerce website and to the public may contain chemicals and other substances known to the State of California to cause cancer and birth defects and other reproductive harm.

Totes made of vinyl, imitation leather, and/or leather material contain lead and/or other substances that are known to the State of California to cause cancer, birth defects and other reproductive harm.

Galvanized metal and some of its constituents contain lead and/or other substances that are known to the State of California to cause cancer, birth defects and other reproductive harm.

Products made of vinyl contain lead, Diethyl Hexyl Phthalate (DEHP), and/or other substances that are known to the State of California to cause cancer, birth defects and other reproductive harm.

Acrylic may contain Acrylic Acid and/or other substances that are known to the State of California to cause cancer, birth defects, and other reproductive harm.

Appliances may contain tin or lead in either the paint or the controllers, and/or other substances that are known to the State of California to cause cancer, birth defects, and other reproductive harm.

Our barware items may contain plastic, acrylic, enamel, crystal, metal and/or other substances that are known to the State of California to cause cancer, birth defects, and other reproductive harm.

Appliances may contain Tin, Lead or Nickel.

**Damage:** All damages must be noted at time of delivery. If a bill is signed that there is no damage, buyer accepts delivery as free and clear. Any claim for damages of the goods, when FOB Destination, that incurred during shipment by the carrier are insured and handled directly with the carrier by the Seller if noted on the receipt and notified within 48 hours of delivery. OPEN AND INSPECT YOUR DELIVERY. When FOB Destination, if the item is damaged by the freight company, and Purchaser cancels rather than accepts a replacement, the order can be cancelled by paying for freight costs both ways and a 35% restocking fee for stocked items. No cancellation or refunds on custom/made or made to order products. When shipped 3rd Party (FOB Warehouse), Purchaser assumes all responsibility for delivery, payment of freight and freight claims for damages during shipment. Manufacture defects will be handled directly with Seller, subject to the limited warranty below.

**Fees:** All sales are final. Unless authorized in writing by the Seller, Purchaser may not return the goods under any circumstance. If Seller agrees in writing to take back stocked goods, there will be a restocking/service fee that is 35% of the purchase price of the goods and freight both ways (product must be new, unused, and in original packaging). If Purchaser returns goods claiming that the goods are defective and goods are found to be in working condition by the Seller, Purchaser is liable for the cost of freight both ways plus and a service fee that is 35% of the purchase price of the goods. Built to Order and Custom products are nonreturnable, nonrefundable. Purchaser must notify Seller of nonconforming goods within 48 hours of receipt, after which time all goods are deemed accepted by the Purchaser. If an order has been placed and production has not started, cancellation of your order will be a 15% charge. If Purchaser tenders payment with a check that has insufficient funds (NSF), a collection fee plus NSF fee of \$50 will be added to the invoice, which Purchaser agrees to pay promptly. If Purchaser puts a stop payment on a check or credit card for any reason, Purchaser agrees to pay for all costs associated with the Seller's collection or litigation of such a claim, including, without limitation, general and special damages, court costs and attorneys' fees. Finance charges begin the date of invoice. Title to the goods reverts back to the Seller in the case of nonpayment of goods or services. All fees and costs to retrieve the product, cost of freight, legal costs, collection fees and court fees, credit card fees and interest rate of 18% (annual rate) will be the responsibility of the Purchaser. In a credit card dispute, Purchaser assumes and must immediately pay

any "credit card arbitration" fees and chargeback fees which the credit card companies charge at the time of the chargeback. Cancelled orders using a Credit Card will have an additional fee of 3% deducted from the refund. Any disputes not resolved within 30 days from the invoice date will be reported to credit reporting agencies.

**LIMITED WARRANTY:** Seller warrants that the goods will be free of defects in materials and workmanship as follows: Furniture style (wood) wine cabinets made in the U.S.: all cooling unit parts only for a period of 5 (five) years; cabinetry and labor (uninstalled) for a period of 12 (twelve) Months (Model numbers "Vino" and "Custom". Metal cabinet units (appliances) (compressor) (made in China and Denmark) (Model numbers start with EL, VT, IL, or EP: parts and labor for cooling system and cabinetry for a period of 12 (twelve) months. Thermoelectric Units: 90 (ninety) days (including Wine and Beverage Coolers, Beer Dispensers, Humidor, Portofino Wood Cellars, and Refrigerators). (Models start with EL, VT, IL or EP). WineMate and Cellar Tec (WM, Wine Mate or CT) (Wine Cooling Units) Split and Ducted Systems and other installed cooling units are parts only for 1 year, no labor. Self Contained WineMate Cooling Systems are 5 years parts, 1year labor. Removal and reinstallation of cooling units is not included. Wine Accessories, Racking Systems, Parts and Other miscellaneous items is a 30 day warranty. Il Romanzo units: Warranty 90 (ninety) days. Replacement part 12 (twelve) months from the date of sale. Non-New Units (Scratch & Dent/Refurbished/Floor Models), warranty for compressor units is 90 days from your dated invoice and 30 days for thermoelectric units (parts for function only, not cosmetic defects). These units are refurbished and sold as is; Purchaser assumes risks to the quality and performance of goods and assumes the costs of all necessary service or repair not covered herein. Extended warranties via New Leaf may not be purchased on Non-New Units. Delivery is curbside. Upgrades in delivery will require an additional fee. Element Grills (via Element Products LLC), grills have a thirty day limited parts warranty on grill accessories. If a model is not listed here will have 90 day warranty on parts only if it's a new item.

**Parts and Repairs:**

Warranty on in-house repairs: 90 days parts and labor for compressor; 30 days parts and labor for Thermoelectric; Customer is required to put down a labor deposit of \$75 for Thermoelectric units; \$150 for compressor based Wine Coolers and \$195 for WineMate units which will be kept if a unit is found to be in good working condition. Customer is responsible for freight costs to us.

Warranty on parts purchased: 30 days; if part fails within 30 days of purchase, customer is to ship us back the part; upon inspection, if defective, VT will send replacement part at no charge.

If a purchaser claims a product is "defective" with regards to refrigeration, Purchaser must obtain a letter from a qualified refrigeration technician at the Purchaser's cost to verify that the unit was installed properly, with proper ventilation and the unit is truly malfunctioning due to a manufacturing defect.

Removal or reinstallation of a unit is not included in warranted costs. Purchaser's exclusive remedy is limited at Seller's option to repair or replace defective part[s] with either new or reconditioned part[s]. Purchaser is responsible for shipping the unit prepaid to a designated facility and Seller will pay return shipping charges in the continental United States for items repaired under warranty within 12 (twelve) months from date of sale. The returned unit must be packaged correctly, with enough protection to ensure the unit is not further damaged. Oversized or lack of packaging is not permitted and will be refused. Replacement or exchanged units will be returned to Purchaser through curbside delivery only. Any redelivery fees are the Purchasers responsibility. Since the natural variation in texture, density, grain, color, tone, and shade of wood is unavoidable; Seller does not guarantee the texture, color, tone, or shade of the wood: nor does seller guarantee the colorfastness of wood or against peeling, chipping, cracking, or scratching. Note: Unfinished wood is subject to warping; all wood surfaces must be sealed before placing cellar into service. Make sure doors are aligned by reviewing the owner's manual. Improper repair or placement of the unit will void the warranty. Any third party repair facility must be preapproved in writing by Seller, before providing replacement parts under warranty. Change Orders: Custom units already in production that require a change will be subject to a change order fee.

**Storage Fees:** When having an item serviced by a Vinotemp service technician at the Vinotemp facility, Purchaser agrees to pick up their repaired item or make arrangements for return shipping within a 60day period once they have been notified by Vinotemp through phone call, email, or letter that their unit is ready for pick up. If the item remains in the Vinotemp warehouse after 60 days but no longer than 120 days, the Purchaser will incur additional storage fees of 2%. After 120 days in storage, the item will become property of Vinotemp. Warranty period is from the date of sale (not from shipping, delivery, nor installation). All completed cabinetry, racking, or other custom work must be picked up or shipped within a period of 14 days after Vinotemp has notified the Purchaser by phone call, email, or letter. Any completed cabinetry, racking, or other custom work stored longer than 14 days will incur an additional storage fee. After 120 days, the product will become property of Vinotemp.

This Limited Warranty does not cover damage due to such things as accident, misuse, abuse, mishandling, neglect, acts of God, fires, earthquakes, floods, high winds, government, war, riot or labor trouble, strikes, lockouts, delay of carrier, unauthorized repair, or any other cause beyond the control of the Seller, whether similar or dissimilar to the foregoing. Seller is not responsible for any damages caused to Purchaser's property resulting from the goods. This limited warranty applies only inside the Continental US (Alaska, Puerto Rico, Hawaii and other territories/countries are not warranted). Purchaser understands and acknowledges that the goods sold here are wine cellars, cigar humidors, and/or other similar units which house wine or cigars or other items. Purchaser assumes all risk of using these units, including risk of spoilage, humidity variations, temperature variations, leaks, fire, water damage, mold, mildew, dryness and similar and any other perils that might occur. Seller is not responsible for incidental or consequential damages, and there are no warranties, expressed or implied, which extend beyond the Limited Warranty described above. Warranty and liability are nontransferable. The implied warranties of merchantability and of fitness for a particular purpose are hereby expressly disclaimed. Some states do not allow the exclusion of incidental or consequential damages, or a waiver of the implied warranties of fitness and/or merchantability, so the above limitations may not apply to you. This warranty gives you specific legal rights and you may also have other rights which vary from state to state. Seller disclaims any indemnification for claims of infringement of any intellectual property of protectable nature. In the event of any dispute between Seller and Purchaser arising out of or relating to these terms and conditions or to the goods sold generally,

Purchaser must first file a written claim with Seller within ten days of the occurrence giving rise to the claim and wait an additional thirty days for a response before initiating any legal action. The sale and all terms are subject to California law. Any legal proceeding arising out of or relating to these terms and conditions or to the goods sold Purchaser shall bring, solely and exclusively in the County of Los Angeles. In no event may Purchaser initiate any legal proceeding more than six months after the occurrence of the event giving rise to the dispute. Seller may make nonpayment claims until debt is paid in full. Any dispute or claim relating in any way to these to the Terms and Conditions, the Website, or any products or services sold or distributed by or through this Website, store, or catalog will be resolved by binding arbitration, rather than in court, except that you may assert claims in small claims court if your claims qualify. The Federal Arbitration Act and federal arbitration law apply to the Terms and Conditions. We each agree that any dispute resolution proceedings will be conducted only on an individual basis and not in a class, consolidated or representative action. If for any reason a claim proceeds in court rather than in arbitration we each waive any right to a jury trial. Both parties agree to bring suit in court to enjoin infringement or other misuse of intellectual property rights.

The above terms and conditions are the only ones governing this transaction and Seller makes no oral representations of any kind. These Terms and Conditions can only be modified in writing, signed by both Purchaser and Seller.  
12/17









## **SERVICE & IMPORTANT NOTICE**

Upon receipt and inspection of unit, the supply cord must be replaced if it is damaged. Contact our customer service at 1-800-777-8466 or [info@vinotemp.com](mailto:info@vinotemp.com).

The manufacturer has a policy of continuous improvement on its products and reserves the right to change materials and specifications without notice.

### **WARNING:**

**Please do not place the unit within reach of children.  
For adult use only.**

Contact **[info@vinotemp.com](mailto:info@vinotemp.com)** with any questions or visit

**[www.vinotemp.com](http://www.vinotemp.com)**



17621 S. Susana Road  
Rancho Dominguez, CA 90221  
[www.vinotemp.com](http://www.vinotemp.com)

Vinotemp is a registered trademark of Vinotemp International. All products, features, and services are subject to change without notice. We cannot guarantee the accuracy of the contents of this document. We disclaim liability for errors, omissions, or future changes.

© 2018 Vinotemp International. All rights reserved.